

SOPORTES ELECTRICOS®

PRODUCTOS



MEXICO, D. F. • MONTERREY
GUADALAJARA • QUERETARO
SAN LUIS POTOSI • PUEBLA



MENSAJE DEL DIRECTOR

En SOPORTES ELECTRICOS tenemos muy claro el propósito de crecer y desarrollar innovaciones para brindar a nuestros clientes el mejor servicio y la más alta calidad en nuestros productos.

Por esta razón me es muy grato presentar nuestro Catálogo 2019, en donde una vez más adicionamos nuevos productos para poder brindarle una mayor variedad, siempre con la finalidad de apoyar para resolver en su beneficio cualquier reto que se presente en el campo de las instalaciones eléctricas.

Esperamos que este Catálogo les sea una herramienta útil y efectiva para resolver las dudas que surjan en el campo de trabajo y satisfaga todas sus necesidades.

Nuestros productos están respaldados por organismos certificadores como UL, ANCE Y LAPEM, manufacturados con materiales de la mas alta calidad para que usted pueda confiar que en sus proyectos de instalación tengan seguridad garantizada y completa satisfacción

SOPORTES ELECTRICOS reitera su compromiso de seguir trabajando para brindarle el mejor producto, atención y servicio, tratando de aportar nuestro granito de arena en el crecimiento del país. Sabemos que es un camino que no podemos recorrer solos, por lo que agradecemos la confianza que a lo largo de los años nos han brindado y que ha sido vital en el desarrollo y éxito de nuestra empresa. Esperamos poder seguir creciendo juntos.

MESSAGE FROM THE DIRECTOR

In SOPORTES ELECTRICOS we are very clear our targets to grow and develop innovations to provide our customers the best service and highest quality products .

For this reason I am pleased to present our 2019 catalog. Once again we add new products in order to provide a greater variety , always with the aim of supporting their advantage to solve any challenge that arises in the field of electrical installations.

We hope this catalog to be useful and effective to solve any doubts arising in the working field and meet all of gear needs.

Our products are backed by certification of UL, ANCE and LAPEM, manufactured with materials of the highest quality so you can trust that your installation projects are guaranteed safety and complete satisfaction

“SOPORTES ELECTRICOS” reiterates its commitment to continue working to provide the best products, service and attention; collaborating with our bit for the country's growth. We know it is a path that we can't walk alone, and we appreciate your continuous support and confidence provided over the years, which has been vital in the development and success of our company.

We look forward to keep growing together!

INFORMACION TECNICA DE CHAROLAS

IT4-IT8

SECCION "FIBRA DE VIDRIO"

A1-A26

SECCION 1 "CHAROLAS"

SECCION 1.1	TRAMOS RECTOS Y ACC. "CHAROLA TIPO ESCALERA"	9
SECCION 1.2	TRAMOS RECTOS Y ACC. "CHAROLA TIPO FONDO SOLIDO"	20
SECCION 1.3	ACCESORIOS DE ENSAMBLE	29
SECCION 1.4	ACCESORIOS DE MONTAJE	34
SECCION 1.5	"CHAROLAS TIPO MARINO"	39
SECCION 1.6	"CHAROLAS TIPO MALLA"	44

SECCION 2 "CANAL VENTILADO"

SECCION 2.1	TRAMOS RECTOS Y ACCESORIOS DE ENSAMBLE	56
SECCION 2.2	ACCESORIOS DE MONTAJE "CANAL"	61

SECCION 3 "DUCTO"

SECCION 4.1	DUCTO CUADRADO EMBISAGRADO	62
SECCION 4.2	DUCTO CON TAPA A PRESION NEMA 1 / IP-41	67
SECCION 4.3	DUCTO CON VENA Y CAÑUELA NEMA 5, 12 / IP-55	71

SECCION 4 "UNICANAL"

SECCION 5.1	TRAMOS RECTOS "UNICANAL"	75
SECCION 5.2	ACCESORIOS DE ENSAMBLE "UNICANAL"	84
SECCION 5.3	ACCESORIOS MONTAJE "UNICANAL"	95
SECCION 5.4	DATOS DE INGENIERIA	101

SECCION 5 "ABRAZADERAS PARA TUBERIA"

SECCION 6.1	ABRAZADERA PARA UNICANAL	101
SECCION 6.2	ABRAZADERA PARA TUBERIA	102
SECCION 6.3	ABRAZADERA TIPO "U"	103
SECCION 6.4	ABRAZADERA COLGANTE	104

INDICE POR CLAVE DE CATALOGO

106

TECHNICAL INFORMATION

IT4-IT8

SECTION "FIBERGLASS"

A1-A26

SECTION 1 "CABLE TRAYS"

SECTION 1.1	"STRAIGHT SECTIONS FITTINGS FOR LADDER TYPE"	9
SECTION 1.2	"STRAIGHT SECTIONS FITTINGS FOR SOLID TROUGH TYPE"	20
SECTION 1.3	"SPLICE PLATES"	29
SECTION 1.4	"SUPPORTS AND BRACKETS"	34
SECTION 1.5	"MARINE TYPE CABLE TRAY SYSTEM"	39
SECTION 1.6	"CABLE TRAY SYSTEM WIRE MESH TYPE"	44

SECTION 2 "CABLE CHANNEL"

SECTION 2.1	STRAIGHT SECTIONS AND FITTINGS	56
SECTION 2.2	CABLE CHANNEL SUPPORTS	61

SECTION 3 "WIREWAY"

SECTION 4.1	SQUARE WIREWAY NEMA 1 / IP30	62
SECTION 4.2	PRESSED COVER WIREWAY NEMA 1 / IP-40	67
SECTION 4.3	PACKED AND PRESSED WIREWAY NEMA 5, 12 / IP-54	71

SECTION 4 "UNICANAL"

SECTION 5.1	STRAIGHT SECTIONS "UNICANAL"	75
SECTION 5.2	UNICANAL FITTINGS	84
SECTION 5.3	UNICANAL ACCESORIES	95
SECTION 5.4	ENGINEERING DATA	101

SECTION 5 "PIPE CLAMPS"

SECTION 6.1	CHANNEL CONDUIT CLAMPS	101
SECTION 6.2	CONDUIT PIPE CLAMP	102
SECTION 6.3	U-BOLT	103
SECTION 6.4	SUSPENSION RED PIPE CLAMP AND HOOK CLAMP	104

INDEX

106

INTRODUCCION

SOPORTES ELECTRICOS, a través de sus 30 años de servicio en México. Es una de las empresas más importantes fabricantes de **SOPORTERÍA PARA INSTALACIONES ELÉCTRICAS**.

SOPORTES ELECTRICOS Se ha preocupado por que sus Sistemas de Soportes para cable, tipo **charola metálica, fibra de vidrio, ductos, Unicanales, herrajes y soportería** se encuentren respaldados por tecnología de vanguardia con un compromiso inalterable de calidad.

SOPORTES ELECTRICOS, con sus 2 plantas de manufactura localizadas en el Estado de México y Monterrey, N. L. cuentan con los últimos adelantos tecnológicos en la fabricación de Soportes para Instalaciones Eléctricas realizando con empeño y dedicación nuevos desarrollos de productos para cubrir las necesidades de la Industria Nacional e Internacional.

SOPORTES ELECTRICOS, manufactura soportes con los más altos estándares de Calidad y tiene reconocimientos de Organismos como la Asociación de Normalización y Certificación, A. C. (ANCE), y laboratorio de la C.F.E. (LAPEM) y UL.

SOPORTES ELECTRICOS, está desarrollando orgullosamente el Sistema de Calidad **ISO 9002** para garantizar un servicio distintivo de la más **ALTA CALIDAD** esforzándonos día a día para que usted obtenga los mejores resultados de seguridad y confiabilidad en sus Instalaciones Eléctricas.

Con el fin de mejorar y mantener nuestra calidad, todos nuestros productos están sujetos a cambio de diseño sin previo aviso tomando como base las normas anteriormente descritas.

INTRODUCTION

SOPORTES ELECTRICOS has been giving service to customers in México since 30 years ago. Our company has become as one of the most important manufacturers of these products for electrical installations.

SOPORTES ELECTRICOS concern it self on an inalterable compromise of quality and vanguard technology for our cable support systems as metallic trays, fiberglass, wireway, unistrut and fittings.

SOPORTES ELECTRICOS has two manufacture plants, located in México State and Monterrey, N.L., with most of top equipment and technological advances for manufacturing of supports for electrical installations and a great determination in development of new products to satisfy needs of national and foreign industry.

SOPORTES ELECTRICOS is manufacturing with the highest quality standards and recognitions as: ANCE (Normalization and Clasification Asociation, A.C.), LAPEM (CFE Laboratory for Electrical Tests and Measurement) and UL.

In **SOPORTES ELECTRICOS** we are very proud to be in development of **ISO 9002** quality system to guaranty a distinctive service of highest quality with our day by day efforts for you to obtain the best results and confidence for your electrical installations. With our purpose to update our products and sustain our quality on all of them, we would be improving our designs everytime, taking into account the norms we have described before.

Se considera un sistema de soportería tipo charola para cable a una estructura rígida y continua especialmente construida para soportar cables, tubos u otras canalizaciones, las cuales pueden ser de metal u otros materiales no combustibles.

Las charolas para cables SOPORTES ELECTRICOS pueden usarse para soportar cables de fuerza, alumbrado, control y señalización que cuenten con aislamiento y cubierta apropiados para este tipo de instalación.

Las charolas SOPORTES ELECTRICOS se encuentran disponibles en materiales y acabados adecuados para su instalación a la intemperie o en condiciones ambientales desfavorables.

No se permite su instalación en cubos de ascensores o en aquellos lugares donde estén expuestos a daños mecánicos severos o en áreas clasificadas.

Las charolas para cables de SOPORTES ELECTRICOS cuentan con la suficiente rigidez y resistencia mecánica para proporcionar un soporte adecuado a todo el cableado tendido dentro de ellas.

SOPORTES ELECTRICOS cuenta con una amplia gama de charolas metálicas protegidas contra la corrosión, así como no metálicas e incluyen todos los accesorios necesarios para realizar cambios de dirección o de nivel requeridos durante la instalación.

Todas las labores de diseño y fabricación de las charolas SOPORTES ELECTRICOS se realizan apegados a las normas tanto nacionales (NMX-J511-ANCE-2011, NOM-001 SEDE 2012) como internacionales (NEMA VE 1-2009)

De esta manera el cálculo de las características de un sistema de soportería , tal como ancho, alturas, radios, distancia entre travesaños, etc.

El propósito de este catálogo de soportería para cables es el de ayudar a Ingenieros, Projectistas y Compradores en la selección del material idóneo que cumpla con las características obtenidas en los cálculos indicados en las normas.

Debido a nuestra política de mejora continua de nuestros productos, las especificaciones, dimensiones, así como toda información contenida en este catálogo podrá ser modificada sin previo aviso.

Estamos seguros de que las ventajas que usted encontrará en nuestro sistema de soportería para cables, le convencerán de que:

**!!!!!!EN CHAROLAS
SEGUIMOS SIENDO LA MEJOR OPCION!!!!!!**

A cable tray systems is considered as a rigid and continuous structure made of metal or other type of non-flammable materials which are built specially to support cable, pipes or others types of electrical channels.

The SOPORTES ELECTRICOS cable tray can be used as support of different cable type such power, lighting systems, control signal or data, the cable should have proper insulation or cover for the kind of instalation.

The SOPORTES ELECTRICOS cable tray is available in materials and finishes for outdoors or hostile enviroment conditions

The cable tray systems can't be installed in elevators shafts or areas exposed to mechanical damage.

The cable tray systems can't be installed in hazardous locations as indicated in articles 500 to 505 of the NEC code unless use a cable aproved for this areas.

The SOPORTES ELECTRICOS cable tray systems are rigid and high mechanical resistance for a proper support for all the cables contained inside.

SOPORTES ELECTRICOS offers a wide range of cable tray as corrosion resistance metallic system as non-metalic system, both have available the necessary fitting for direction an level changes so, offers a complete instalation.

All the SOPORTES ELECTRICOS cable tray manufacturing process from design to finish are under Mexican (NMX-J511-ANCE-2011, NOM-001 SEDE 2012) as International (NEMA VE 1-2009).

So the calculation of cable tray parameters such as width, height, radius, distance between rungs and others.

This cable tray systems catalog is designed for help to general engineers, project engineers or buyers to right cable tray selection, for cover the requirements obtained for the standards calculations.

SOPORTES ELECTRICOS have a "continuous best product" policy, so the dimensions, specifications and all technical information showed in this catalogs can change without notice.

While every effort has been made to assure the accuracy of information contained in this catalogs at the time of publication, we can not accept responsibility for inaccuracies resulting from undetected errors or omissions

We are sure that the advantages of our cable tray systems will convince you that :

**!!!!!!IN CABLE TRAY SYSTEMS
SOPORTES ELECTRICOS IS THE BEST CHOICE!!!!!!**

MATERIALES DE FABRICACION

Los sistemas de soportería para cables SOPORTES ELECTRICOS son fabricados con materiales de la más alta calidad, adquiridos a empresas certificadas bajo ISO 9000, además son rigurosamente verificados en nuestras instalaciones para entregar a usted un producto acorde con las necesidades de calidad y excelencia que demanda el desarrollo industrial.

Los materiales de fabricación deberán seleccionarse cuidadosamente para lo cual recomendamos consultar nuestro “Manual de selección correcta de un sistema de soportería para cables” editado por SOPORTES ELECTRICOS.

Los materiales disponibles para la fabricación de charolas para cables son :
 Acero al carbono AISI C 1010 HR/CR
 Acero inoxidable AISI-304
 Aluminio AA 6063
 Poliester reforzado con fibra de vidrio, antífama auto-extinguible y protegido contra rayos ultravioleta.

RECUBRIMIENTOS PROTECTORES

Debido a la naturaleza energética de los metales, en ambientes donde se presentan condiciones galvánicas (humedad, agua salda, etc) o exposición a químicos corrosivos, la aplicación de recubrimientos anticorrosivos aumentará la vida útil de los materiales. El sistema de soportería para cables de SOPORTES ELECTRICOS puede ser suministrado con los siguientes recubrimientos protectores:

1.- Para productos de acero al carbono :

- Galvanizado por inmersión en caliente después de manufactura según ASTM A 123
- Galvanizado por inmersión en caliente antes de manufactura según ASTM A 525
- Galvanizado electrolítico según ASTM B 633
- Tropicalizado
- Recubrimiento de PVC según NEMA NR 1
- Acabado epóxico

Nota : el acero al carbono no se surte en acabado natural

2.- Para productos de aluminio:

- Acabado natural (oxidación protectora natural)
- Recubrimiento de PVC según NEMA NR 1
- Acabado epóxico

Los productos de acero inoxidable se surten en acabado natural.

Para recubrimientos especiales favor de consultar con nuestro Departamento de Ingeniería.

**!!!!!!EN CHAROLAS
 SEGUIMOS SIENDO LA MEJOR OPCION!!!!!!**

MANUFACTURING MATERIALS

The SOPORTES ELECTRICOS cable tray systems is made with high quality materials, all our suppliers are ISO 9000 certificated, also the materials are strictly inspected in our facilities for provide to you a product acordig with your needes of quality and excellence.

The manufacturing materials should be carefull selected, for this we recomend consult our published by “Manual de selección correcta de un sistema de soportería para cables” SOPORTES ELECTRICOS.

The available materials for cable tray systems are:

Carbon steel AISI C 1010 HR/CR
 Stainless steel AISI-304
 Aluminum AA 6063.
 Polyester fiber glass reinforced flame-retardante, auto-extinguish and protected against UV

FINISHES

The enviroment where a galvanic condition (humidity, salt water, etc.) or corrosive chemical exposure is present; the application of corrosion proof finish is required for plus the lifetime of the product. The SOPORTES ELECTRICOS cable tray systems is available in the next protective finishes

1.- For carbon steel products :

- Hot dip galvanized after manufacture under ASTM A 123
- Hot dip galvanized before manufacture under ASTM A 525
- Electrogalvanized under ASTM B 633
- Chromium-zinc coat
- PVC coat under NEMA NR 1
- Epoxy coat

The carbon steel products are not available in natural finish

2.- For aluminum products

- Natural finish (a coat of natural AlO)
- PVC coat under NEMA NR 1
- Epoxy coat

The stainless steel products are availabe in natural finish.

For special coatings please consult our Technical Department.

**!!!!!!IN CABLE TRAY SYSTEMS
 SOPORTES ELECTRICOS
 IS THE BEST CHOICE!!!!!!**

CARGAS SOPORTADAS

Los sistemas de soportería para cables SOPORTES ELECTRICOS al ser diseñados y fabricados bajo la normativa nacional e internacional. cumplen con las características de carga indicadas en dichas normas.

Para tal efecto en las siguientes páginas del catálogo se indicará la clasificación requerida por la norma NMX-J511-ANCE-2011.

Esta norma indica que los sistemas de soportería para cables (específicamente los tramos rectos) deberán ser clasificados de acuerdo a las cargas que soportará ya instalado.

La clasificación consta de un número y una letra que indican :

- 1.- El número indica la distancia DAP máxima entre apoyos del sistema.
- 2.- La letra indicará la carga WS uniformemente repartida de seguridad máxima soportada por el sistema.

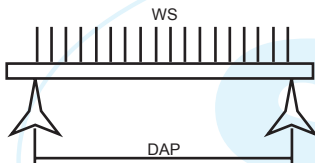

La norma acepta las siguientes distancias entre apoyos para la clasificación:

- 5 para 1.52 m (5 pies)
- 6 para 1.83 m (6 pies)
- 8 para 2.44 m (8 pies)
- 12 para 3.66 m (12 pies)
- 16 para 4.87 m (16 pies)
- 20 para 6.10 m (20 pies)

La norma acepta las siguientes cargas de seguridad soportadas para la clasificación:

- AA para 18.6 kg/m (12.5 Lb/pie)
- BB para 37.2 kg/m (25 Lb/pie)
- A para 74.4 kg/m (50 Lb/pie)
- B para 111.6 kg/m (75 Lb/pie)
- C para 148.8 kg/m (100 Lb/pie)

Por ejemplo un sistema de soportería para cables clasificación NEMA 12C soportará una carga de seguridad de 148.8 kg/m (100 Lb/pie) cuando la distancia entre apoyos es de 3.66 m (12 pies).

La carga de seguridad del sistema es la carga destructiva dividida entre un factor de seguridad mínimo de 1.5. Opcionalmente podrá aplicarse una carga concentrada al centro de la distancia entre apoyos, la magnitud de esta carga deberá ser determinada por el cliente e informada a SOPORTES ELECTRICOS para realizar los estudios de factibilidad correspondientes.

LOAD CAPACITY

The SOPORTES ELECTRICOS cable tray systems are designed follow the concets in standards so they covers the characteristics required for those in load capacity.

For this in the next pages of this catalogs is showed the classification required for the standard NMX-J511-ANCE-2011

This standard say that the cable tray systems (straight sections specifically) should be clasificated acording with the load supported for the instaled system.

The classification is building of a number and a letter as follow:

- 1.- The number indicate the maximum support span DAP.
- 2.- The letter indicate the maximum WS uniform working load.

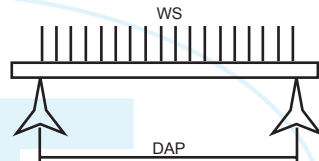

The support span accepted for the clasification are the follow :

- 5 for 5 feet (1.52 m)
- 6 for 6 feet (1.83 m)
- 8 for 8 feet (2.44 m)
- 12 for 12 feet (3.66 m)
- 16 for 16 feet (4.87 m)
- 20 for 20 feet (6.10 m)

The working loads accepted for the clasification are the follow :

- AA for 12.5 Lb/ft (18.6 kg/m)
- BB for 25 Lb/ft (37.2 kg/m)
- A for 50 Lb/ft (74.4 kg/m)
- B for 75 Lb/ft (111.6 kg/m)
- C for 100 Lb/ft (148.8 kg/m)

Example : a NEMA 12C cable tray systems support a working load of 100 Lb/ft (148.8 kg/m) when the support span is 12 ft (3.66 m).

The working load is equivalent to the destruction load divided by a safety factor of 1.5

A concentrated static load is not included in load/span designations but if it is required for the user it should be applied at the center of the span if the combined load exceeds the working load, SOPORTES ELECTRICOS should be consulted

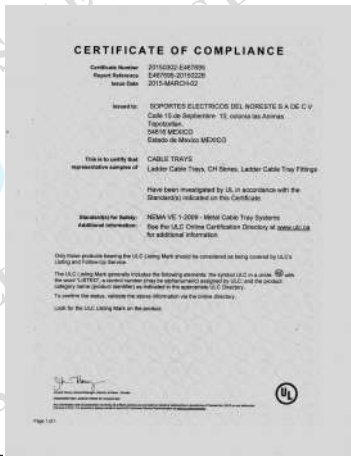

SECCION 1 SISTEMAS DE SOPORTERIA PARA CABLES

SECTION 1 CABLE TRAY SYSTEM

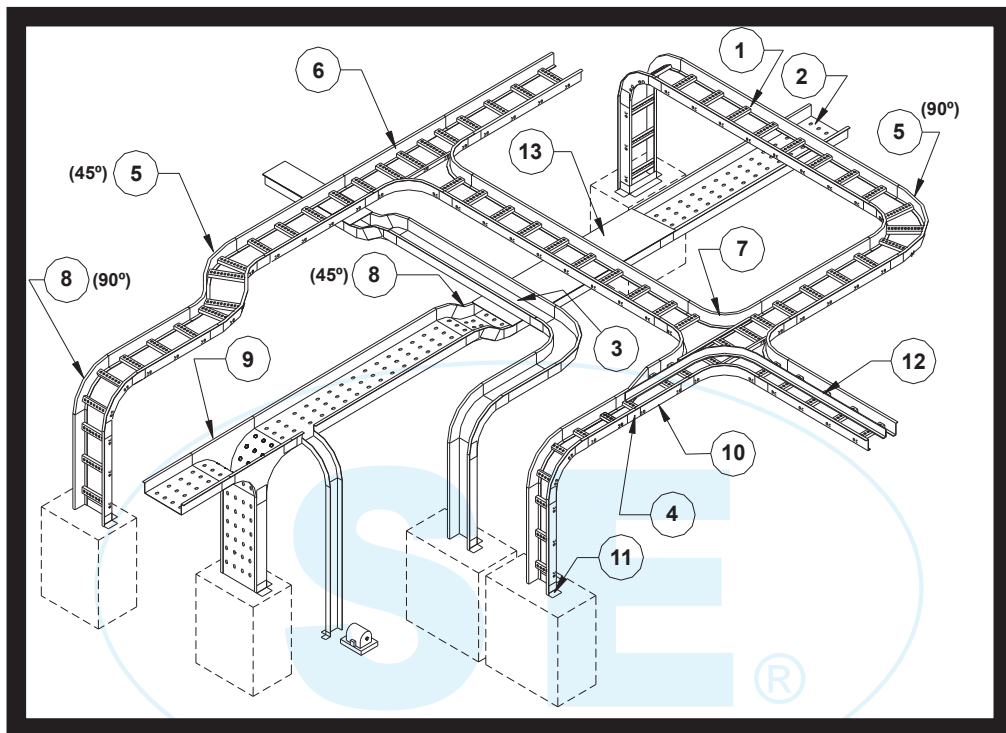

1.- CHAROLA TIPO ESCALERA
LADDER TYPE CABLE TRAY

2.- CHAROLA TIPO TIPO FONDO SOLIDO
PERFORADO
VENTILATED SOLID FLAT BOTTOM
CABLE TRAY

3.- CHAROLA TIPO TIPO FONDO SOLIDO
LISO
SOLID FLAT BOTTOM CABLE TRAY

4.- CONECTOR
SPLICE PLATE

5.- CURVA HORIZONTAL
HORIZONTAL BEND

6.- "T" HORIZONTAL
HORIZONTAL TEE

7.- EQUIS HORIZONTAL
HORIZONTAL CROSS

8.- CURVA VERTICAL INTERIOR
Y EXTERIOR
VERTICAL OUTSIDE AND INSIDE
BEND

9.- "T" VERTICAL
VERTICAL TEE

10.- REDUCCION
REDUCER

11.- CONECTOR DE CHAROLA A CAJA
FRAME TYPE BOX CONNECTOR

12.- BARRERA SEPARADORA
BARRIER STRIP STRAIGHT SECTION

13.- TAPAS (CUBIERTAS)
COVERS

SECCION A FIBRA DE VIDRIO

El sistema de soporte para cables tipo charola fabricado en fibra de vidrio marca SOPORTES ELECTRICOS es ideal en instalaciones donde se requiera una alta resistencia a la corrosión y donde no se requieran materiales conductores.

El sistema brinda un soporte rígido, de alta resistencia a químicos y ambientes corrosivos, así como alta resistencia mecánica y una alta durabilidad en exposición a rayos ultravioleta.

Ademas de brindar una ventilación continua de las líneas eléctricas.

USOS Y APLICACIONES

Por sus características éstas charolas son ideales para su aplicación en:

- Instalaciones petroquímicos
- Tratamiento de los efluentes de desecho y aguas residuales
- Ambientes corrosivos
- Industria petrolera y del gas
- Generación de electricidad
- Procesamiento de alimentos
- Tuneles / transporte público
- Industria pesada
- Molinos de pasta de panel
- Minas.

VENTAJAS

El sistema de soportería para cables tipo charola fabricado en fibra de vidrio marca SOPORTES ELECTRICOS es un sistema diseñado para las condiciones mas severas que brinda además el sistema más ligero y flexible en su instalación comparado con los sistemas metálicos tradicionales.

Las características que hacen del sistema de fibra de vidrio SOPORTES ELECTRICOS, un sistema superior son:

- ✘ **ALTA RESISTENCIA CONTRA RAYOS ULTRAVIOLETA E INTEMPERISMO.-** Los componentes de poliéster reforzados con fibra de vidrio cuentan con un velo protector aplicado en las superficies exteriores para resistir el intemperismo y la acción de los rayos ultravioleta, además, dentro de la formulación EXCLUSIVA DE SOPORTES ELECTRICOS integran estabilizadores que aumentan la resistencia así como pigmentos especiales que sirven como pantalla contra los rayos ultravioleta.
- ✘ **AUTOEXTINGUIBLES Y RETARDANTE DE FUEGO.-** Por pruebas realizadas en laboratorio y en campo, se demuestra que las charolas evitan la propagación del fuego y auto extinguen cualquier flama en un lapso no mayor a 15 segundos, por otro lado los humos generados durante un evento no son tóxicos a bajas exposiciones.
- ✘ **RESISTENCIA A LA TEMPERATURA.-** Las charolas de fibra de vidrio de SOPORTES ELECTRICOS tienen una altísima resistencia a la temperatura y pueden ser utilizadas en cualquier ambiente.
- ✘ **GRAN RESISTENCIA MECÁNICA.-** Por su diseño, materiales y método de fabricación estas charolas son mas fuertes comparadas con los sistemas metálicos.
- ✘ **FACILIDAD DE INSTALACIÓN .-** Las charolas de fibra de vidrio cuentan con una alta resistencia mecánica con un bajo peso.



SECTION A FIBERGLASS

The system supports for cable type tray made with fiberglass brand SOPORTES ELECTRICOS is ideal for installations where high strength is required and where the corroding conductive materials are required.

The system provides a rigid support, high resistance to chemicals and corrosive environments as well as high mechanical strength and high durability on exposure to ultraviolet rays.

Besides to providing continuous ventilation of the electrical lines.

USES AND APPLICATIONS

Because of their characteristics those trays are ideal for use in:

- Petrochemical installations
- Effluent treatment of waste and sewage
- Corrosive environments
- Oil and gas industry
- Electricity generation
- Food processing
- Tunnels / public transport
- Heavy industry
- Panel paste grinders
- Mines.

ADVANTAGES

The system of supports for cable tray made with fiberglass brand SOPORTES ELECTRICOS is a system designed for the most severe conditions that also provides the lightweight and flexible system installation compared to traditional metallic systems.

The characteristics which make the system fiberglass SOPORTES ELECTRICOS, a superior system are:

- ✘ **HIGH STRENGTH AGAINST UV RAYS AND WEATHERING**
The polyester components reinforced with fiberglass have a protective veil applied on the outer surfaces to resist weathering and the action of ultraviolet rays also within the EXCLUSIVE formulation SOPORTES ELÉCTRICOS integrated stabilizers that increase resistance and screen against ultraviolet rays.
- ✘ **SELF-EXTINGUISHING AND FLAME**
For tests conducted in laboratory and field, these shown that the trays prevent the spread of fire and self extinguish any flame on a period no longer than 15 seconds, on the other hand the fumes generated during a event are not toxic at low exposures.
- ✘ **TEMPERATURE RESISTANCE**
The fiberglass trays SOPORTES ELÉCTRICOS have a very high temperature resistance and can be used in any environment.
- ✘ **GREAT MECHANICAL RESISTANCE**
By the design, materials and methods of construction, these trays are stronger compared to metallic systems.
- ✘ **EASY INSTALLATION**
The fiberglass trays counts with high mechanical strength with low weight.

DISEÑO Y PROCESO DE FABRICACIÓN

- ✘ El sistema de soportería para cables de fibra de vidrio SOPORTES ELÉCTRICOS están fabricados en poliéster reforzado.
- ✘ Tanto los perfiles laterales, como los travesaños y todas las partes componentes están manufacturados con el proceso de termofijación exclusivo de SOPORTES ELÉCTRICOS.
- ✘ Los soportes para cables cuentan con rieles laterales en forma de "C" o "E" REFORZADA.
- ✘ Además de la adhesión de los travesaños con los laterales, estos se encuentran firmemente unidos mediante un tornillo fabricado de un termoplástico de alto impacto y alta resistencia mecánica.
- ✘ Diseño del sistema para soporte de cables cumple y sobrepasa las capacidades de carga de acuerdo con lo establecido en la norma NEMA -FG-1, NRF-048 PEMEX y en la resistencia a la flama como muestra la norma ASTM E-84.

PROCESO DE TERMOFIJACIÓN

Los componentes que integran los productos de fibra de vidrio son fabricados reforzando una resina base (poliéster) con múltiples capas de filamentos continuos y alternados con malla de fibra de vidrio. Las capas de fibra de vidrio son sumergidas en resina líquida, la cual impregna y satura las fibras. En el equipo de termofijación, la resina se cura de forma permanente, es decir adquiere la forma de termoflujo. El perfil así procesado puede ser cortado a las longitudes especificadas por nuestros clientes. Debido a que los perfiles cuentan con filamentos de fibra de vidrio permanentemente unidos, presentan una alta resistencia a la tensión, además de una alta resistencia a ambientes corrosivos. Estos atributos hacen de la fibra de vidrio el material a seleccionar en la mayoría de las aplicaciones de la industria con ambientes altamente corrosivos.

SOPORTES ELÉCTRICOS orgullosamente ha implementado el proceso de termofijación en sus instalaciones en la Ciudad de México con el fin de ofrecer en el mercado un producto de tecnología y fabricación:

100% MEXICANOS

DESIGN AND MANUFACTURING PROCESS

- ✘ The fiberglass cable tray support system SOPORTES ELÉCTRICOS are manufactured with reinforced polyester.
- ✘ Both lateral profiles, as the beams and all parts are manufactured using the heat-setting EXCLUSIVE process SOPORTES ELÉCTRICOS.
- ✘ The supports for cables count with lateral rails with "C" OR "E"-shaped REINFORCED.
- ✘ In addition of the adherence of the traverses with the laterals, these are firmly attached by a screw made of thermoplastic of high impact and high mechanical strength..
- ✘ The supporting system design for cables fulfill and exceeds the weight capacities according to the established standards of NEMA-FG-1, NRF-048 PEMEX And in the flame resistance as shown by the standard E-84 ASTM.

HEAT SETTING PROCESS

The components making up the fiberglass products are manufactured reinforcing a resin base (polyester) with multiple capable of continuous filaments and alternating with fiberglass mesh. The fiberglass layers are immersed in liquid resin which impregnates and satire the fibers. In heat setting equipment, the resin is cured to permanently, it is to say acquires termoflujo shape. The profile can be processed and cut to lengths specified by our customers. Because the profiles count with fiberglass filaments permanently attached, have high tensile resistance, and a high resistance to corrosive environments. These attributes make the fiberglass a material to select in most industrial applications in highly corrosive environments.

SOPORTES ELÉCTRICOS proudly implemented the heat setting process at its installations in Mexico City in order to offer the market a product of technology and manufacturing:

100% MEXICAN



ESPECIFICACIONES TECNICAS: FIBRA DE VIDRIO

1.1 Los materiales del sistema de charola cumplen con los requerimientos y especificaciones siguientes:

2.0 Normas

2.1 El sistema de charola cumple con lo indicado en las secciones que aplica de :

- 2.1.1 Norma NEMA VE-2 (Ultima Edición)
- 2.1.2 Codigo Eléctrico Nacional (NEC)
- 2.1.3 ASTM E-84 (Rango Clase 1)
- Normas para Charola Portacable No Metálica
- 2.1.4 NEMA FG1

3.0 General

3.1 Requerimientos de la Charola

3.1.1 Anchos: 6" (152 mm), 9" (229 mm), 12" (305 mm), 16" (406 mm) 18" (457 mm), 20" (508 mm), 24" (610 mm) 30" (762 mm) y 36" (914 mm)

3.1.2 Longitud (según se requiera): 10 pies (3.05 mts) y 20 pies (6.10 mts)

3.1.3 Espaciamiento entre peldaños (según se requiera): 6" (152 mm), 9" (235 mm), 12" (305 mm) y 18" (470 mm)

3.1.4 Radio de Accesorios (según se requiera): 12" (305 mm), 24" (610 mm) y 36" (914 mm)

3.1.5 Resina: Poliester Isoftálmico retardante a la flama (FRP)

3.2 Requerimientos de Carga

3.2.1 Se tiene 3 clasificaciones de carga para charola en fibra de vidrio, basado en soportes a una distancia de 20 pies (6.10 mts) uno del otro:

Clase	Carga de Trabajo Lbs/lineal Ft	Factor de Seguridad Kg/m lineal
A	50 (74.4)	1.5
B	75 (111.6)	1.5
C	100(148.8)	1.5

4.0 General

4.1 La fibra de vidrio contenida en la resina es de: entre 45% y 55% del peso en componentes pultruidos; en placas entre 35% y 45% y de entre 25% y 45% en componentes moldeados.

4.2 Todo material compuesto contiene un aditivo químico inhibidor de luz ultravioleta para resistir la degradación UV.

4.3 Todos los materiales compuestos son retardantes al fuego y cuentan con índice de extinción menor a 25 (Rango Clase 1) al probarse de acuerdo a ASTM E 84

4.4 Todos los productos pultruidos cuentan con un velo protector en la superficie para proporcionar una máxima protección a químicos y rayos (Excepto accesorios radiales)

5.0 Construcción

5.1 Los tramos rectos son de fibra de vidrio reforzada cumpliendo con cada requerimiento aquí descrito

5.1.1 Los elementos laterales con alas hacia adentro arreglados en forma concéntrica

5.1.2 La conexión entre el perfil lateral y el peldaño es con un fijador químico (con adhesivo) y mecánico. La charola es ensamblada con el uso de un perno fijador fabricado en fibra de vidrio reforzado con ermolplástico, y es insertado bajo presión con adhesivo químico de alta resistencia.

5.1.3 El interior de las charolas esta libre de cualquier saliente, rebaba y/o cortante.

5.1.4 Los tramos rectos están previamente perforados, para recibir las placas de conexión.

5.1.5 Todo corte y/o perforación esta cubierto con una capa de sellador compatible con la resina usada

5.2 Los accesorios para charola son fabricados y cumplen cada requerimiento aquí descrito:

5.2.1 Los accesorios tienen un espaciamiento nominal entre peldaños de 9.25" (235 mm) aproximadamente.

5.2.2 Los accesorios estan previamente perforados, para recibir las placas de conexión.

5.2.3 El diseño puede ser radial o estructural.

5.2.4 La conexión entre el perfil lateral y el peldaño es con un fijador químico (con adhesivo) y mecánico. El accesorio es ensamblado con el uso de un perno fijador fabricado en fibra de vidrio reforzado con termoplástico y es insertado bajo presión con un adhesivo químico de alta resistencia.

Nota: las curva verticales, horizontales a 90° y 45° tees y cruces son diseñados con radio concéntrico continuo; fabricados en molde por transferencia de resina

5.3 Placas de Conexión.

5.3.1 Las placas de conexión son fabricados de fibra de vidrio y están diseñadas con la suficiente resistencia para no reducir la capacidad de carga de la charola.

TECHNICAL SPECIFICATIONS: FIBERGLASS

1.1 All the material of the tray system, meet the following requirements and specifications:

2.0 Standards

2.1 The tray system meets the standards indicated in the following sections:

- 2.1.1 NEMA VE-2 Standard (Last edition)
- 2.1.2 National Electrical Code (NEC)
- 2.1.3 ASTM E-84 (Range Class 1)
Standards for Non-Metallic Cable Holder
- 2.1.4 NEMA FG1

3.0 General

3.1 Tray Requirements

- 3.1.1 Widths: 6" (152 mm), 9" (229 mm), 12" (305 mm), 16" (406 mm), 18" (457 mm), 20" (508 mm), 24" (610 mm) 30" (766 mm), y 36" (914 mm)
- 3.1.2 Length (as required): 10 feet (3.05 m) and 20 feet (6.10 m)
- 3.1.3 Spacing between steps (as required): 6" (152 mm), 9" (235 mm), 12" (305 mm), 18" (470 mm)
- 3.1.4 Accessories Radius (as required): 12" (305 mm), 24" (610 mm) and 36" (914 mm)
- 3.1.5 Resin: Isophthalic Polyester flame retardant (FRP)

3.2 Electric Load Requirements:

3.2.1 There are 3 different classifications for fiberglass tray, based on supports with a spacing of 20 feet (6.10 m) between each other.

Class	Workload Lbs/lineal Ft	Safety Factor Kg/m lineal
A	50 (74.4)	1.5
B	75 (111.6)	1.5
C	100(148.8)	1.5

4.0 General

4.1 The fiberglass contained in the resin is: 45% to 55% of the pultruded components weight, 35% to 45% of plates and 25% to 45% of molded components.

4.2 Every composite contains a chemical additive as an ultraviolet light inhibitor to resist the degradation caused by ultraviolet rays' exposing.

4.3 All composites are fire retardant and have an extinction rate of less than 25 (Range class 1) as tested under the standard ASTM E 84.

4.4 All pultruded components have a protective veil on the surface, to provide maximum protection against chemical and rays. (except radial accessories)

5.0 Construction

5.1 The straight sections are made of reinforced fiberglass and they meet all of the following requirements:

5.1.1 Side elements inward winged concentrically arranged.

5.1.2 The connection between the side element and the step is done with a chemical (adhesive) and mechanical fixative. The tray is assembled by a fiberglass manufactured and thermoplastic reinforced pin-fixer which is press-inserted with a high strength chemical adhesive.

5.1.3 The inside of the tray is free of any burr or sharp piece.

5.1.4 The straight sections are previously drilled and ready to connect the plates.

5.1.5 Every cutting and drilling is covered with a layer of compatible sealant to the used resin.

5.2 The tray accessories are manufactured meeting all the following requirements:

5.2.1 The accessories have a nominal spacing of 9.25" (235 mm) between every step.

5.2.2 The accessories are previously drilled and ready to connect the plates.

5.2.3 The design can be radial or structural.

5.2.4 The connection between the side element and the step is done with a chemical (adhesive) and mechanical fixative. The tray is assembled by a fiberglass manufactured and thermoplastic reinforced pin-fixer which is press-inserted with a high strength chemical adhesive.

Note: The vertical and horizontal 90° and 45° curves as well as the lees and crosses are designed with a continuous concentric radius. They are also manufactured under a resin transfer molding process.

5.3 Connection plates:

5.3.1 The connection plates are fiberglass manufactured and they are designed and made with sufficient strength in order to do not reduce the tray's workload.

TRAMOS RECTOS TIPO ESCALERA PARA CABLES

STRAIGHT SECTIONS LADDER TYPE

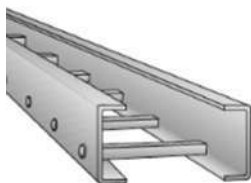

CHC -1212-6FV-6

LONGITUD/LENGTH
6 = 6.10 m (20')
3 = 3.05 m (10')

MATERIAL/MATERIAL
FV= FIBRA DE VIDRIO/
FIBERGLASS

PERALTE / HEIGHT

PASO / STEP

ANCHO / WIDTH

PERFIL TIPO "C" / "E"

RAIL TYPE "C" / "E"

CHAROLA TIPO ESCALERA /
TRAY LADDER TYPE

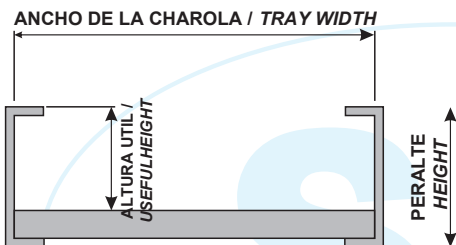

PERALTE HEIGHT	ALTURA UTIL USEFUL HEIGHT
4" (102 mm)	3" (76 mm)
6" (152 mm)	4 1/4" (107.6 mm)

ANCHO DE LA CHAROLA TRAY WIDTH	PASO NOMINAL / NOMINAL STEP			
	6" (152 mm)	9" (229 mm)	12" (305 mm)	18" (457 mm)
6" (152 mm)	CHC-0606	CHC-0609	CHC-0612	CHC-0618
9" (229 mm)	CHC-0906	CHC-0909	CHC-0912	CHC-0918
12" (305 mm)	CHC-1206	CHC-1209	CHC-1212	CHC-1218
16" (406 mm)	CHC-1606	CHC-1609	CHC-1612	CHC-1618
18" (457 mm)	CHC-1806	CHC-1809	CHC-1812	CHC-1818
20" (508 mm)	CHC-2006	CHC-2009	CHC-2012	CHC-2018
24" (610 mm)	CHC-2406	CHC-2409	CHC-2412	CHC-2418
30" (762 mm)	CHC-3006	CHC-3009	CHC-3012	*
36" (914 mm)	CHC-3606	CHC-3609	CHC-3612	*

NOTAS / NOTES:

- EN ANCHOS DE 30" y 36" NO SE FABRICAN EN PASO 18"
IN WIDTH 30 "and 36" NOT MANUFACTURED IN STEP 18 "
- EN PASO DE 9" Y 18" SE CONSIDERAN NOMINALES Y SON AJUSTADOS A LA LONGITUD DE LA CHAROLA.
IN STEP 9" AND 18" ARE CONSIDERED NOMINAL AND ARE ADJUSTED TO THE LENGTH OF THE TRAY.
- LAS LONGITUDES DE LA CHAROLA SON DE 10' (3.05M) Y 20" (6.10M)
THE LENGTHS TRAY ARE 10' (3.05M) AND 20" (6.10M)
- CADA CHAROLA INCLUYE 2 CONECTORES RECTOS Y TORNILLERÍA.
EACH TRAY INCLUDES 2 STRAIGHT CONNECTORS AND HARDWARE.

PUEDO SER SUJETO A MODIFICACION SIN PREVIO AVISO / MAYBE SUBJECT TO MODIFICATION WITHOUT NOTICE

CURVA HORIZONTAL A 90°

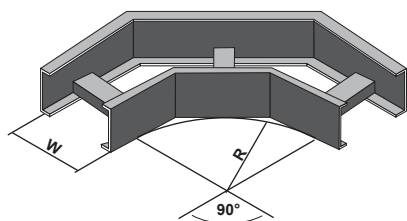

VH C-12R12-90-6FV-E

90° HORIZONTAL BEND

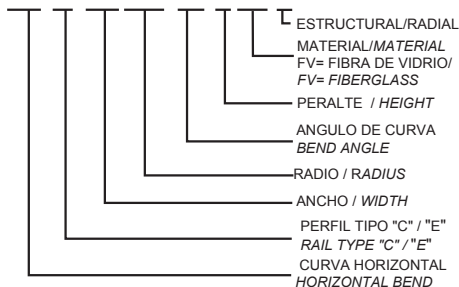

ANCHO DE LA CHAROLA TRAY WIDTH	RADIO / RADIUS		
	12" (305 mm)	24" (610 mm)	36" (914 mm)
6" (152 mm)	VHC-06R12-90	VHC-06R24-90	VHC-06R36-90
9" (229 mm)	VHC-09R12-90	VHC-09R24-90	VHC-09R36-90
12" (305 mm)	VHC-12R12-90	VHC-12R24-90	VHC-12R36-90
16" (406 mm)	VHC-16R12-90	VHC-16R24-90	VHC-16R36-90
18" (457 mm)	VHC-18R12-90	VHC-18R24-90	VHC-18R36-90
20" (508 mm)	VHC-20R12-90	VHC-20R24-90	VHC-20R36-90
24" (610 mm)	VHC-24R12-90	VHC-24R24-90	VHC-24R36-90
30" (762 mm)	VHC-30R12-90	VHC-30R24-90	VHC-30R36-90
36" (914 mm)	VHC-36R12-90	VHC-36R24-90	VHC-36R36-90

CURVA HORIZONTAL A 45°

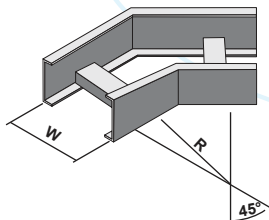

VH C-12R12-45-6FV-E

45° HORIZONTAL BEND

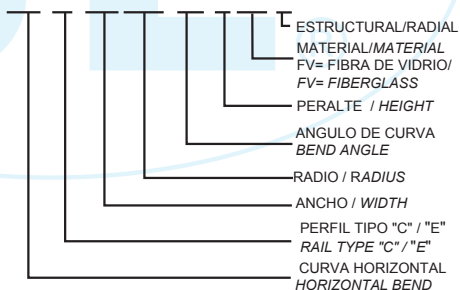

ANCHO DE LA CHAROLA TRAY WIDTH	RADIO / RADIUS		
	12" (305 mm)	24" (610 mm)	36" (914 mm)
6" (152 mm)	VHC-06R12-45	VHC-06R24-45	VHC-06R36-45
9" (229 mm)	VHC-09R12-45	VHC-09R24-45	VHC-09R36-45
12" (305 mm)	VHC-12R12-45	VHC-12R24-45	VHC-12R36-45
16" (406 mm)	VHC-16R12-45	VHC-16R24-45	VHC-16R36-45
18" (457 mm)	VHC-18R12-45	VHC-18R24-45	VHC-18R36-45
20" (508 mm)	VHC-20R12-45	VHC-20R24-45	VHC-20R36-45
24" (610 mm)	VHC-24R12-45	VHC-24R24-45	VHC-24R36-45
30" (762 mm)	VHC-30R12-45	VHC-30R24-45	VHC-30R36-45
36" (914 mm)	VHC-36R12-45	VHC-36R24-45	VHC-36R36-45

CADA CURVA INCLUYE 2 CONECTORES RECTOS y TORNILLERÍA
EACH BEND INCLUDES 2 STRAIGHT CONECTORS AND HARDWARE

PUEDEN SER SUJETOS A MODIFICACION SIN PREVIO AVISO / MAYBE SUBJECT TO MODIFICATION WITHOUT NOTICE
ACCESORIOS EN PERFIL TIPO "E" SON FABRICADOS ESTRUCTURALES / ACCESSORIES IN RAIL TYPE "E" MANUFACTURED SEGMENTED

CURVA VERTICAL EXTERIOR A 90°

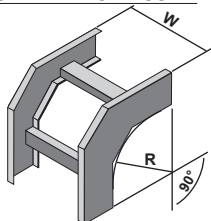

LOS ACCESORIOS SE PUEDEN FABRICAR RADIALES Ó ESTRUCTURAL.
ACCESSORIES CAN BE MANUFACTURED RADIALS OR ESTRUCTURAL

VE C-12R12-90-6FV-E

90° OUTSIDE VERTICAL BEND

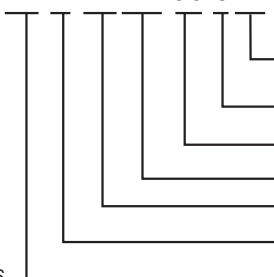

ESTRUCTURAL/RADIAL
MATERIAL/MATERIAL
FV= FIBRA DE VIDRIO/
FV= FIBERGLASS
PERALTE / HEIGHT
ANGULO DE CURVA
BEND ANGLE
RADIO / RADIUS
ANCHO / WIDTH
PERFIL TIPO "C" / "E"
RAIL TYPE "C" / "E"
CURVA HORIZONTAL
HORIZONTAL BEND

ANCHO DE LA CHAROLA TRAY WIDTH	RADIO / RADIUS		
	12" (305 mm)	24" (610 mm)	36" (914 mm)
6" (152 mm)	VEC-06R12-90	VEC-06R24-90	VEC-06R36-90
9" (229 mm)	VEC-09R12-90	VEC-09R24-90	VEC-09R36-90
12" (305 mm)	VEC-12R12-90	VEC-12R24-90	VEC-12R36-90
16" (406 mm)	VEC-16R12-90	VEC-16R24-90	VEC-16R36-90
18" (457 mm)	VEC-18R12-90	VEC-18R24-90	VEC-18R36-90
20" (508 mm)	VEC-20R12-90	VEC-20R24-90	VEC-20R36-90
24" (610 mm)	VEC-24R12-90	VEC-24R24-90	VEC-24R36-90
30" (762 mm)	VEC-30R12-90	VEC-30R24-90	VEC-30R36-90
36" (914 mm)	VEC-36R12-90	VEC-36R24-90	VEC-36R36-90

CURVA VERTICAL EXTERIOR A 45°

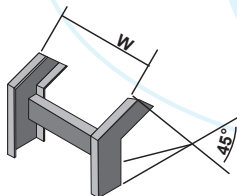

LOS ACCESORIOS SE PUEDEN FABRICAR RADIALES O SECCIONADOS
ACCESSORIES CAN BE MANUFACTURED RADIALS OR SECTIONED.

VE C-12R12-45-6FV-E

45° OUTSIDE VERTICAL BEND

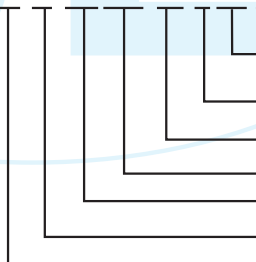

ESTRUCTURAL/RADIAL
MATERIAL/MATERIAL
FV= FIBRA DE VIDRIO/
FV= FIBERGLASS
PERALTE / HEIGHT
ANGULO DE CURVA
BEND ANGLE
RADIO / RADIUS
ANCHO / WIDTH
PERFIL TIPO "C" / "E"
RAIL TYPE "C" / "E"
CURVA HORIZONTAL
HORIZONTAL BEND

ANCHO DE LA CHAROLA TRAY WIDTH	RADIO / RADIUS		
	12" (305 mm)	24" (610 mm)	36" (914 mm)
6" (152 mm)	VEC-06R12-45	VEC-06R24-45	VEC-06R36-45
9" (229 mm)	VEC-09R12-45	VEC-09R24-45	VEC-09R36-45
12" (305 mm)	VEC-12R12-45	VEC-12R24-45	VEC-12R36-45
16" (406 mm)	VEC-16R12-45	VEC-16R24-45	VEC-16R36-45
18" (457 mm)	VEC-18R12-45	VEC-18R24-45	VEC-18R36-45
20" (508 mm)	VEC-20R12-45	VEC-20R24-45	VEC-20R36-45
24" (610 mm)	VEC-24R12-45	VEC-24R24-45	VEC-24R36-45
30" (762 mm)	VEC-30R12-45	VEC-30R24-45	VEC-30R36-45
36" (914 mm)	VEC-36R12-45	VEC-36R24-45	VEC-36R36-45

CADA CURVA INCLUYE 2 CONECTORES RECTOS y TORNILLERÍA
EACH BEND INCLUDES 2 STRAIGHT CONNECTORS AND HARDWARE.

PUEDA SER SUJETO A MODIFICACION SIN PREVIO AVISO / MAYBE SUBJECT TO MODIFICATION WITHOUT NOTICE
ACCESORIOS EN PERFIL TIPO "E" SON FABRICADOS ESTRUCTURALES / ACCESSORIES IN RAIL TYPE "E" MANUFACTURED SEGMENTED

CURVA VERTICAL INTERIOR A 90°

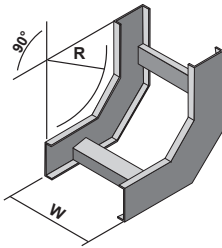

VI C-12R12-90-6FV-E

90° INSIDE VERTICAL BEND

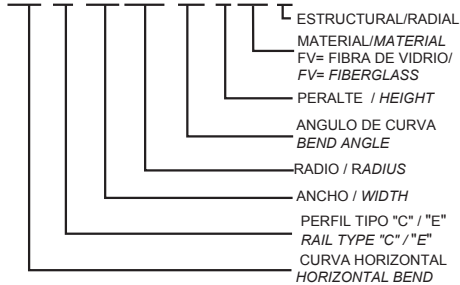

ANCHO DE LA CHAROLA TRAY WIDTH	RADIO / RADIUS		
	12" (305 mm)	24" (610 mm)	36" (914 mm)
6" (152 mm)	VIC-06R 12-90	VIC-06R 24-90	VIC-06R 36-90
9" (229 mm)	VIC-09R 12-90	VIC-09R 24-90	VIC-09R 36-90
12" (305 mm)	VIC-12R 12-90	VIC-12R 24-90	VIC-12R 36-90
16" (406 mm)	VIC-16R 12-90	VIC-16R 24-90	VIC-16R 36-90
18" (457 mm)	VIC-18R 12-90	VIC-18R 24-90	VIC-18R 36-90
20" (508 mm)	VIC-20R 12-90	VIC-20R 24-90	VIC-20R 36-90
24" (610 mm)	VIC-24R 12-90	VIC-24R 24-90	VIC-24R 36-90
30" (762 mm)	VIC-30R 12-90	VIC-30R 24-90	VIC-30R 36-90
36" (914 mm)	VIC-36R 12-90	VIC-36R 24-90	VIC-36R 36-90

CURVA VERTICAL INTERIOR A 45°

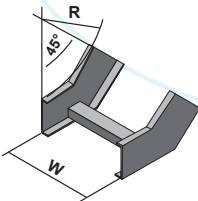

VI C-12R12-45-6FV-E

45° INSIDE VERTICAL BEND

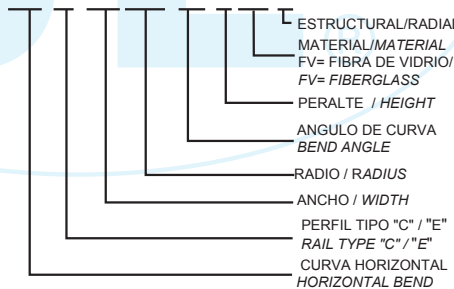

ANCHO DE LA CHAROLA TRAY WIDTH	RADIO / RADIUS		
	12" (305 mm)	24" (610 mm)	36" (914 mm)
6" (152 mm)	VIC-06R12-45	VIC-06R24-45	VIC-06R36-45
9" (229 mm)	VIC-09R12-45	VIC-09R24-45	VIC-09R36-45
12" (305 mm)	VIC-12R12-45	VIC-12R24-45	VIC-12R36-45
16" (406 mm)	VIC-16R12-45	VIC-16R24-45	VIC-16R36-45
18" (457 mm)	VIC-18R12-45	VIC-18R24-45	VIC-18R36-45
20" (508 mm)	VIC-20R12-45	VIC-20R24-45	VIC-20R36-45
24" (610 mm)	VIC-24R12-45	VIC-24R24-45	VIC-24R36-45
30" (762 mm)	VIC-30R12-45	VIC-30R24-45	VIC-30R36-45
36" (914 mm)	VIC-36R12-45	VIC-36R24-45	VIC-36R36-45

CADA CURVA INCLUYE 2 CONECTORES RECTOS y TORNILLERÍA
 EACH BEND INCLUDES 2 STRAIGHT CONNECTORS AND HARDWARE.
 PUEDE SER SUJETO A MODIFICACION SIN PREVIO AVISO / MAYBE SUBJECT TO MODIFICATION WITHOUT NOTICE
 ACCESORIOS EN PERFIL TIPO "E" SON FABRICADOS ESTRUCTURALES / ACCESSORIES IN RAIL TYPE "E" MANUFACTURED SEGMENTED

"T" HORIZONTAL

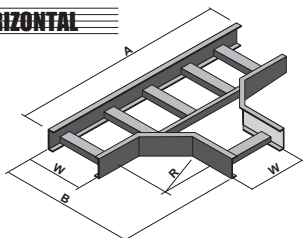

LOS ACCESORIOS SE PUEDEN FABRICAR RADIAL Ó ESTRUCTURAL.
ACCESSORIES CAN BE MANUFACTURED RADIAL OR ESTRUCTURAL.

TH C-12R12-6FV-E

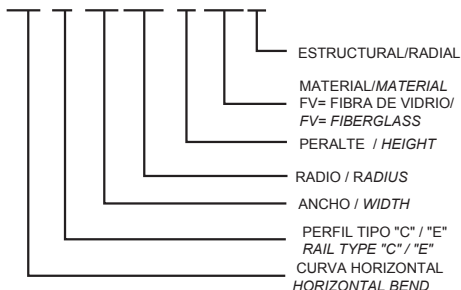

HORIZONTAL "T"

ANCHO DE LA CHAROLA TRAY WIDTH	RADIO / RADIUS		
	12" (305 mm)	24" (610 mm)	36" (914 mm)
6" (152 mm)	THC-06R12	THC-06R24	THC-06R 36
9" (229 mm)	THC-09R12	THC-09R24	THC-09R 36
12" (305 mm)	THC-12R12	THC-12R24	THC-12R 36
16" (406 mm)	THC-16R12	THC-16R24	THC-16R 36
18" (457 mm)	THC-18R12	THC-18R24	THC-18R 36
20" (508 mm)	THC-20R12	THC-20R24	THC-20R 36
24" (610 mm)	THC-24R12	THC-24R24	THC-24R 36
30" (762 mm)	THC-30R12	THC-30R24	THC-30R 36
36" (914 mm)	THC-36R12	THC-36R24	THC-36R 36

"K" HORIZONTAL

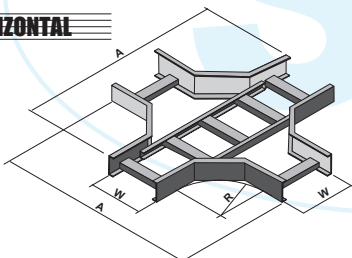

LOS ACCESORIOS SE PUEDEN FABRICAR RADIAL Ó ESTRUCTURAL.
ACCESSORIES CAN BE MANUFACTURED RADIAL OR ESTRUCTURAL.

XH C-12R12-6FV-E

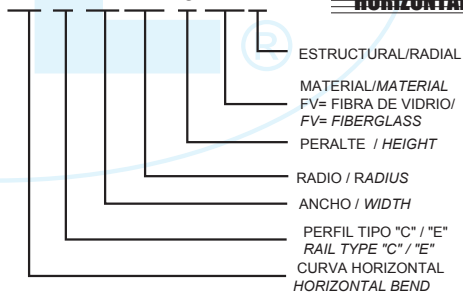

HORIZONTAL "K"

ANCHO DE LA CHAROLA TRAY WIDTH	RADIO / RADIUS		
	12" (305 mm)	24" (610 mm)	36" (914 mm)
6" (152 mm)	XHC-06R12	XHC-06R24	XHC-06R 36
9" (229 mm)	XHC-09R12	XHC-09R24	XHC-09R 36
12" (305 mm)	XHC-12R12	XHC-12R24	XHC-12R 36
16" (406 mm)	XHC-16R12	XHC-16R24	XHC-16R 36
18" (457 mm)	XHC-18R12	XHC-18R24	XHC-18R 36
20" (508 mm)	XHC-20R12	XHC-20R24	XHC-20R 36
24" (610 mm)	XHC-24R12	XHC-24R24	XHC-24R 36
30" (762 mm)	XHC-30R12	XHC-30R24	XHC-30R 36
36" (914 mm)	XHC-36R12	XHC-36R24	XHC-36R 36

CADA ACCESORIO INCLUYE 2 CONECTORES RECTOS y TORNILLERÍA
EACH ACCESSORY INCLUDES 2 STRAIGHT CONNECTORS AND HARDWARE.

PUEDEN SER SUJETOS A MODIFICACION SIN PREVIO AVISO / MAYBE SUBJECT TO MODIFICATION WITHOUT NOTICE
ACCESORIOS EN PERFIL TIPO "E" SON FABRICADOS ESTRUCTURALES / ACCESSORIES IN RAIL TYPE "E" MANUFACTURED SEGMENTED

REDUCCIONES

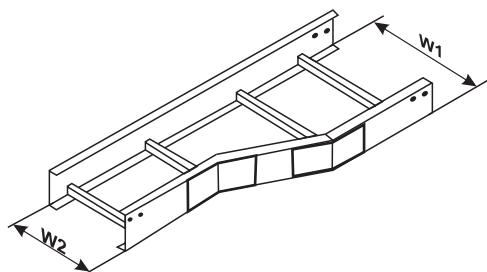

RLDC - 1206-6FV

REDUCERS

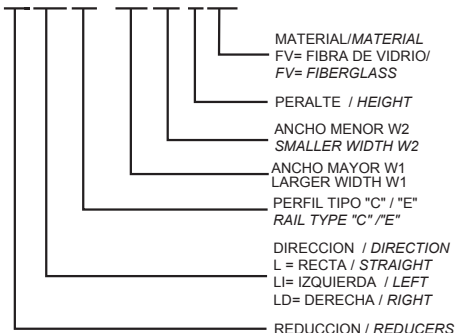

REDUCCIONES DERECHAS

RIGHT REDUCERS

W1	W2							
	6" (152mm)	9" (229mm)	12" (305mm)	16" (406mm)	18" (457mm)	20" (508mm)	24" (610mm)	30" (762mm)
9" (229 mm)	RLDC-0906							
12" (305 mm)	RLDC-1206	RLDC-1209						
16" (406 mm)	RLDC-1606	RLDC-1609	RLDC-16 12					
18" (457 mm)	RLDC-1806	RLDC-1809	RLDC-18 12	RLDC-1816				
20" (508 mm)	RLDC-2006	RLDC-2009	RLDC-20 12	RLDC-2016	RLDC-20 18			
24" (610 mm)	RLDC-2406	RLDC-2409	RLDC-24 12	RLDC-2416	RLDC-24 18	RLDC-2420		
30" (762 mm)	RLDC-3006	RLDC-3009	RLDC-30 12	RLDC-3016	RLDC-30 18	RLDC-3020	RLDC-3024	
36" (914 mm)	RLDC-3606	RLDC-3609	RLDC-36 12	RLDC-3616	RLDC-36 18	RLDC-3620	RLDC-3624	RLDC-3630

REDUCCIONES IZQUIERDAS

LEFT REDUCERS

W1	W2							
	6" (152mm)	9" (229mm)	12" (305mm)	16" (406mm)	18" (457mm)	20" (508mm)	24" (610mm)	30" (762mm)
9" (229 mm)	RLIC-0906							
12" (305 mm)	RLIC-1206	RLIC-1209						
16" (406 mm)	RLIC-1606	RLIC-1609	RLIC-16 12					
18" (457 mm)	RLIC-1806	RLIC-1809	RLIC-18 12	RLIC-1816				
20" (508 mm)	RLIC-2006	RLIC-2009	RLIC-20 12	RLIC-2016	RLIC-20 18			
24" (610 mm)	RLIC-2406	RLIC-2409	RLIC-24 12	RLIC-2416	RLIC-24 18	RLIC-2420		
30" (762 mm)	RLIC-3006	RLIC-3009	RLIC-30 12	RLIC-3016	RLIC-30 18	RLIC-3020	RLIC-3024	
36" (914 mm)	RLIC-3606	RLIC-3609	RLIC-36 12	RLIC-3616	RLIC-36 18	RLIC-3620	RLIC-3624	RLIC-3630

REDUCCIONES RECTAS

STRAIGHT REDUCERS

W1	W2							
	6" (152mm)	9" (229mm)	12" (305mm)	16" (406mm)	18" (457mm)	20" (508mm)	24" (610mm)	30" (762mm)
9" (229 mm)	RLC-09 06							
12" (305 mm)	RLC-12 06	RLC-12 09						
16" (406 mm)	RLC-16 06	RLC-16 09	RLC-1612					
18" (457 mm)	RLC-18 06	RLC-18 09	RLC-1812	RLC-1816				
20" (508 mm)	RLC-20 06	RLC-20 09	RLC-2012	RLC-2016	RLC-2018			
24" (610 mm)	RLC-24 06	RLC-24 09	RLC-2412	RLC-2416	RLC-2418	RLC-2420		
30" (762 mm)	RLC-30 06	RLC-30 09	RLC-3012	RLC-3016	RLC-3018	RLC-3020	RLC-3024	
36" (914 mm)	RLC-36 06	RLC-36 09	RLC-3612	RLC-3616	RLC-3618	RLC-3620	RLC-3624	RLC-3630

CADA ACCESORIO INCLUYE 2 CONECTORES RECTOS y TORNILLERÍA
EACH ACCESSORY INCLUDES 2 STRAIGHT CONNECTORS AND HARDWARE.

PUEDEN SER SUJETOS A MODIFICACION SIN PREVIO AVISO / MAYBE SUBJECT TO MODIFICATION WITHOUT NOTICE

"T" VERTICAL

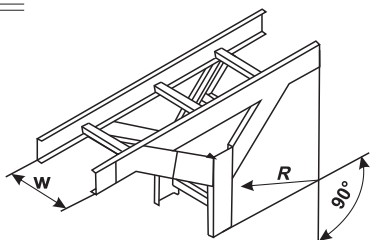

TV C-12R12-6FV

VERTICAL "T"

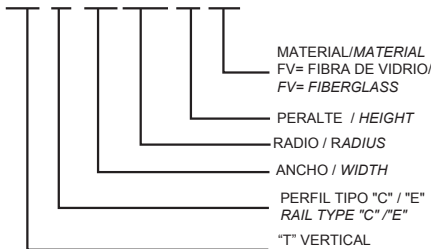

ANCHO DE LA CHAROLA TRAY WIDTH	RADIO / RADIUS		
	12" (305 mm)	24" (610 mm)	36" (914 mm)
6" (152 mm)	TVC-06R12	TVC-06R24	TVC-06R36
9" (229 mm)	TVC-09R12	TVC-09R24	TVC-09R36
12" (305 mm)	TVC-12R12	TVC-12R24	TVC-12R36
16" (406 mm)	TVC-16R12	TVC-16R24	TVC-16R36
18" (457 mm)	TVC-18R12	TVC-18R24	TVC-18R36
20" (508 mm)	TVC-20R12	TVC-20R24	TVC-20R36
24" (610 mm)	TVC-24R12	TVC-24R24	TVC-24R36
30" (762 mm)	TVC-30R12	TVC-30R24	TVC-30R36
36" (914 mm)	TVC-36R12	TVC-36R24	TVC-36R36

CADA ACCESORIO INCLUYE 2 CONECTORES RECTOS y TORNILLERÍA
EACH ACCESSORY INCLUDES 2 STRAIGHT CONNECTORS AND HARDWARE.

BARRERAS SEPARADORAS

DIVIDERS STRIP

LAS BARRERAS SEPARADORAS PARA TRAMOS RECTOS SE SURTEN EN LONGITUDES DE 3,05 METROS Y DEBERAN SER INSTALADAS EN CAMPO.

THE DIVIDERS STRIP FOR STRAIGHT SECTIONS ARE FILLED IN LENGTHS OF 3.05 METERS AND SHOULD BE INSTALLED IN FIELD.

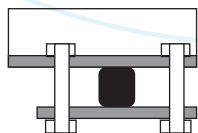

ARREGLO TRAVESAÑO CUADRADO
UNDER TRANSOM SQUARE

BS -6FV

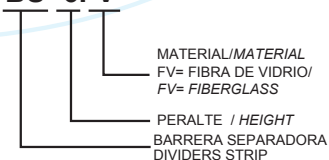

CLIP DE SUJECIÓN CLIP -BS / CLIP RETAINING CLIP-BS

CADA BARRERA SEPARADORA INCLUYE 3 JUEGOS DE CLIPS (PLACAS Y TORNILLERÍA)
EACH DIVIDERS STRIP INCLUDES 3 SETS OF CLIPS (PLATES AND HARDWARE)

DEBIDO A QUE ES IMPOSIBLE DETERMINAR CON ANTICIPACIÓN LA POSICIÓN DE LA BARRERA EN UN ACCESORIO, PARA ACCESORIOS HORIZONTALES NO HAY BARRERAS SEPARADORAS SE MANEJAN EN ACERO INOXIDABLE. CUANDO SE REALICEN BARRERAS PARA ACCESORIOS SE DEBERAN SOLICITAR CLIPS ADICIONALES.

BECAUSE IT IS IMPOSSIBLE TO DETERMINE IN ADVANCE THE STRIP POSITION IN AN ACCESSORY, WHEN REQUIRED ACCESSORIES FOR HORIZONTAL NO BARRIERS SEPARATING HANDLED IN STAINLESS STEEL. WHEN MAKING ACCESSORIES BARRIERS ADDITIONAL CLIPS SHOULD BE REQUESTED.

PUEDER SER SUJETO A MODIFICACION SIN PREVIO AVISO / MAYBE SUBJECT TO MODIFICATION WITHOUT NOTICE

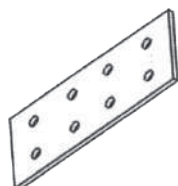

RECTO ESTÁNDAR TIPO AR
STANDARD STRAIGHT TYPE AR

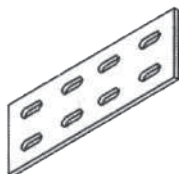

EXPANSION TIPO AE
EXPANSION TYPE AE

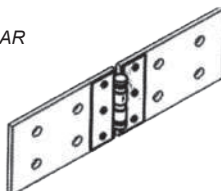

AJUSTABLE HORIZONTAL TIPO AH
HORIZONTAL AJUSTABLE TYPE AH

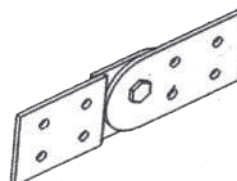

AJUSTABLE VERTICAL TIPO EA
VERTICAL AJUSTABLE TYPE EA

AH -6FV

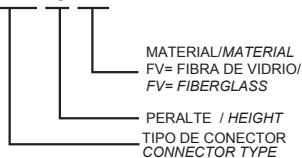

**CONECTORES VERTICALES
DE ANGULO FIJO.**
**VERTICAL CONNECTORS
FIXED ANGLE.**



A 22.5° TIPO AV22
A 22.5° TYPE AV22

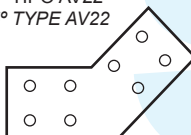

A 45° TIPO AV45
TYPE A 45° AV45

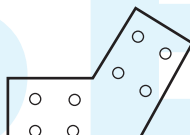

A 60° TIPO AV60
TYPE A 60° AV60

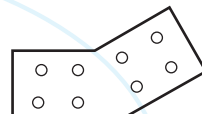

A 30° TIPO AV30
TYPE A 30° AV30

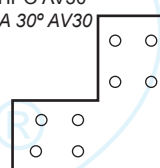

A 90° TIPO AV90
TYPE A 90° AV90

CADA CONECTOR INCLUYE TORNILLERÍA NECESARIA
EACH CONECTOR INCLUDES HARDWARE REQUIRED

PLACAS TERMINALES
TERMINAL PLATES

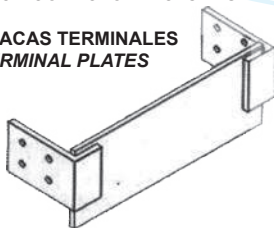

PTR-06-6FV

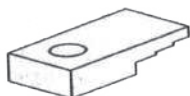
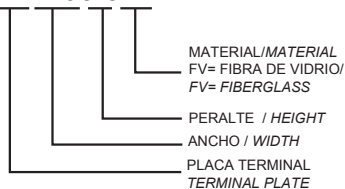

CLEMA-FV DE SUJECIÓN
SECURING CLAMP -FV

CADA CLEMA Ó TAPA TERMINAL INCLUYEN TORNILLERÍA NECESARIA.
EACH CLAMP OR COVER INCLUDE HARDWARE NEEDED.

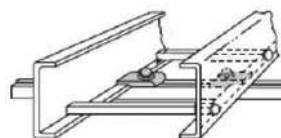

PUEDEN SER SUJETOS A MODIFICACION SIN PREVIO AVISO / MAYBE SUBJECT TO MODIFICATION WITHOUT NOTICE

TAPAS RECTAS SIN VENTILACION

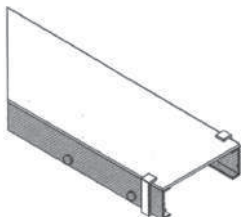

TR VEC-12R12-90-6FV

MATERIAL/MATERIAL
FV= FIBRA DE VIDRIO/
FV= FIBERGLASS
PERALTE / HEIGHT
No. DE CATALOGO DE CHAROLA
O ACCESORIO POR CUBRIR
TRAY CATALOG No.
OR ACCESSORY FOR COVER
TAPA RECTA
STRAIGHT COVER.

LA LONGITUD DE LA TAPA PARA TRAMO RECTO ES DE 3.048M
CADA TAPA PARA TRAMO RECTO INCLUYE 6 CLIPS DE SUJECION DE ACERO INOXIDABLE
EL NÚMERO DE CLIPS PARA TAPAS DE ACCESORIOS ESTARAN EN FUNCION DEL ACCESORIO.
THE LENGTH OF THE COVER FOR STRAIGHT SECTION IS 3,048M
EACH COVER FOR STRAIGHT SECTIONS INCLUDES 6 RETAINING CLIPS OF STAINLESS STEEL
NUMBER OF CLIPS DEPENDS ON TYPE OF FITTING

TAPAS RECTAS CON VENTILACION

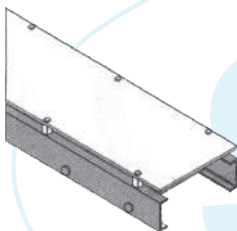

TRV VEC-12R12-90-6FV

MATERIAL/MATERIAL
FV= FIBRA DE VIDRIO/
FV= FIBERGLASS
PERALTE / HEIGHT
No. DE CATALOGO DE CHAROLA
O ACCESORIO POR CUBRIR
TRAY CATALOG No.
OR ACCESSORY FOR COVER
TAPA RECTA CON VENTILACION
STRAIGHT COVERS WITH VENTILATION

LA LONGITUD DE LA TAPA PARA TRAMO RECTO ES DE 3.048M
CADA TAPA PARA TRAMO RECTO INCLUYE 7 PARES DE JUEGOS DE CLIPS DE SUJECION.
EL NÚMERO DE CLIPS PARA TAPAS DE ACCESORIOS ESTARAN EN FUNCION DEL ACCESORIO.
LAS PERFORACIONES DE ANCLAJE DEBERAN SER REALIZADAS EN CAMPO.
THE LENGTH OF THE COVER FOR STRAIGHT SECTION IS 3,048M
EACH COVER FOR STRAIGHT SECTIONS INCLUDES 7 PAIRS OF SETS OF RETAINING CLIPS.
NUMBER OF CLIPS DEPENDS ON TYPE OF FITTING
THE ANCHOR DRILLING MUST BE PERFORMED IN FIELD

TAPAS A DOS AGUAS CON VENTILACION

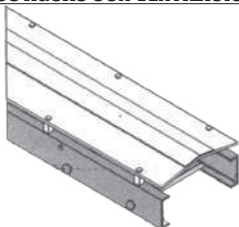

TWO WATERS COVERS WITH VENTILATION

TA CHC-2409-6FV

MATERIAL/MATERIAL
FV= FIBRA DE VIDRIO/
FV= FIBERGLASS
PERALTE / HEIGHT
No. DE CATALOGO DE
CHAROLA POR CUBRIR
TRAY CATALOG No.
FOR COVER
TAPA 2 AGUAS CON
VENTILACION
TWO WATERS COVER
WITH VENTILATION.

LA LONGITUD DE LA TAPA PARA TRAMO RECTO ES DE 3.048M
CADA TAPA PARA TRAMO RECTO INCLUYE 7 PARES DE JUEGOS DE CLIPS DE SUJECION.
ESTE TIPO DE TAPA NO ESTA DISPONIBLE PARA ACCESORIOS.
LAS PERFORACIONES DE ANCLAJE DEBERAN SER REALIZADAS EN CAMPO.
THE LENGTH OF THE COVER FOR STRAIGHT SECTION IS 3,048M
EACH COVER FOR STRAIGHT SECTIONS INCLUDES 7 PAIRS OF SETS OF RETAINING CLIPS.
THIS TYPE OF COVER IS NOT AVAILABLE FOR FITTINGS
THE ANCHOR DRILLING MUST BE PERFORMED IN FIELD

PUEDA SER SUJETO A MODIFICACION SIN PREVIO AVISO / MAYBE SUBJECT TO MODIFICATION WITHOUT NOTICE

SISTEMA DE CANALETA DE FIBRA DE VIDRIO

FIBERGLASS CUTTER SYSTEM

La charola tipo canaleta de Fibra de Vidrio para instrumentación de SOPORTES ELÉCTRICOS estan diseñadas para carga liviana de cableado individual y tubería neumática. Como se ilustra, se ofrece con fondo liso o perforado(ventilado).

La canaleta ventilada tiene orificios con diámetros de 0.75" (19mm) en centros escalonados, de 9.25" (235mm) o 12" (305mm), tanto del lado derecho como izquierdo del entramado.

Todos los tramos rectos y accesorios pre-ensamblados cuentan con perforaciones para instalar las placas de conexión. Todas las placas de conexión y tornillería se venden por separado

The fiberglass canal type tray "SOPORTES ELÉCTRICOS" are designed for light load for individual cabling and pneumatic tubing. As illustrated, is offered with solid and ventilated bottom type.

The ventilated canal has holes with diameters of 0.75" (19mm) staggered centers, 9.25" (235mm), both the right and left side of the assembly.

All straight sections and pre-assembled accessories count with holes to install the connection plates and hardware are sold separately.

INFORMACION TECNICA

TECHNICAL INFORMATION

Ancho de Canaleta Canal Width	Punto de Apoyo Point Support	Carga Máxima Maximum Load	Deflexión Máxima Maximum Deflection
	Pie (Mt)	Lbs./Pie (N/Mt)	Pulg (mm)
3" (76 mm)	5 (1.5)	3.9 (5.79)	0.5 (12.7)
	8 (2.4)	1.0 (1.48)	0.8 (20.3)
4" (102 mm)	8 (2.4)	2.8 (4.16)	0.8 (20.3)
	10 (3.0)	1.5 (2.23)	1.0 (25.4)
6" (152 mm)	10 (3.0)	2.8 (4.16)	1.0 (25.4)
8" (203 mm)	10 (3.0)	5.2 (7.73)	1.0 (25.4)
10" (254 mm)	10 (3.0)	20.0(29.73)	1.0(25.4)
	10 (3.0)	3.9 (5.79)	1.0 (25.4)

Las cargas están basadas en la limitación de la deflexión, sobre un valor igual a 1/120 del punto de apoyo

The loads are based on the limitation of deflection, on an equal value to 1/120 point support

Para Canaleta Perforada, reduce la carga un 10%
For a punched canal, reduce the burden to 10%

TRAMOS RECTOS: CANALETA DE FIBRA DE VIDRIO

STRAIGHT SECTIONS: FIBERGLASS CANAL

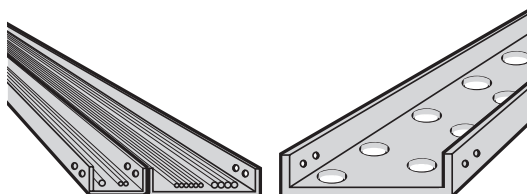

ANCHO W / WIDTH W	ALTURA P / HEIGHT P
3" (76MM)	1 1/2" (38MM)
4" (102MM)	1 1/8" (29MM)
6" (152MM)	1 5/8" (41MM)
8" (203MM)	2 3/16" (56MM)

CHSV - 4305 - FV

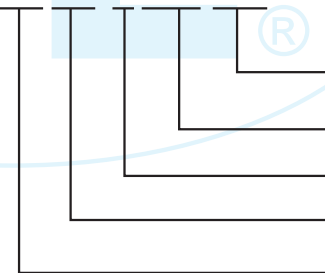

MATERIAL/MATERIAL
 FV= FIBRA DE VIDRIO/
 FV= FIBERGLASS
 LONGITUD/LENGTH
 6 = 6.10 m (20')
 3 = 3.05 m (10')
 ANCHO / WIDTH
 SV = LISO,
 SV = FLAT,
 CV = PERFORADO
 CV = PUNCH
 CANAL / CHANNEL

ANCHO DE LA CHAROLA TRAY WIDTH	TIPO LISO / FLAT TYPE		PERFORADO / PUNCH	
	10' (3.05m)	20' (6.10m)	10' (3.05m)	20' (6.10m)
	3" (76MM)	CHSV-3 305FV	CHSV-3 610FV	CHCV-3 305FV
4" (102MM)	CHSV-4 305FV	CHSV-4 610FV	CHCV-4 305FV	CHCV-4 610FV
6" (152MM)	CHSV-6 305FV	CHSV-6 610FV	CHCV-6 305FV	CHCV-6 610FV
8" (203MM)	CHSV-8 305FV	CHSV-8 610FV	CHCV-8 305FV	CHCV-8 610FV

ACCESORIOS PARA CANALETA DE FIBRA DE VIDRIO

CURVA HORIZONTAL A 90°

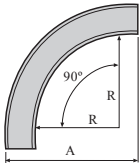

VH SV - 03 - FV



MATERIAL/MATERIAL
FV= FIBRA DE VIDRIO/
FV= FIBERGLASS
ANCHO / WIDTH
SV =SOLIDO / SOLID
CV = VENTILADO/VENTILATED
CURVA HORIZONTAL
HORIZONTAL BLEND

FITTINGS FOR FIBERGLASS CANAL

90° HORIZONTAL BEND

Ancho de Canaleta Canal Width	No. de Catalogo Tipo Liso Catalog Number Flat Type	No. de Catalogo Tipo ventilado Catalog Number ventileted Type
	Radio - 12" (306 mm)	Radio - 12" (306 mm)
3" (76 mm)	VHSV-03R12-90-FV	VHCV-03R12-90-FV
4" (102 mm)	VHSV-04R12-90-FV	VHCV-04R12-90-FV
6" (152 mm)	VHSV-06R12-90-FV	VHCV-06R12-90-FV
8" (203 mm)	VHSV-08R12-90-FV	VHCV-08R12-90-FV

CURVA VERTICAL EXTERIOR A 90°

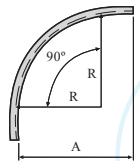

VE SV - 03 - FV

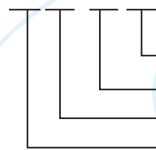

MATERIAL/MATERIAL
FV= FIBRA DE VIDRIO/
FV= FIBERGLASS
ANCHO / WIDTH
SV =SOLIDO / SOLID
CV = VENTILADO/VENTILATED
CURVA VERTICAL EXTERIOR
OUTSIDE VERTICAL BLEND

90° OUTSIDE VERTICAL BEND

Ancho de Canaleta Canal Width	No. de Catalogo Tipo Liso Catalog Number Flat Type	No. de Catalogo Tipo ventilado Catalog Number ventileted Type
	Radio - 12" (306 mm)	Radio - 12" (306 mm)
3" (76 mm)	VESV-03R12-90-FV	VECV-03R12-90-FV
4" (102 mm)	VESV-04R12-90-FV	VECV-04R12-90-FV
6" (152 mm)	VESV-06R12-90-FV	VECV-06R12-90-FV
8" (203 mm)	VESV-08R12-90-FV	VECV-08R12-90-FV

CURVA VERTICAL INTERIOR A 90°

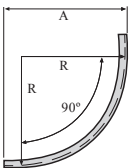

VI SV - 03 - FV



MATERIAL/MATERIAL
FV= FIBRA DE VIDRIO/
FV= FIBERGLASS
ANCHO / WIDTH
SV =SOLIDO / SOLID
CV = VENTILADO/VENTILATED
CURVA VERTICAL INTERIOR
INSIDE VERTICAL BLEND

90° INSIDE VERTICAL BEND

Ancho de Canaleta Canal Width	No. de Catalogo Tipo Liso Catalog Number Flat Type	No. de Catalogo Tipo ventilado Catalog Number ventileted Type
	Radio - 12" (306 mm)	Radio - 12" (306 mm)
3" (76 mm)	VISV-03R12-90-FV	VICV-03R12-90-FV
4" (102 mm)	VISV-04R12-90-FV	VICV-04R12-90-FV
6" (152 mm)	VISV-06R12-90-FV	VICV-06R12-90-FV
8" (203 mm)	VISV-08R12-90-FV	VICV-08R12-90-FV

"T" HORIZONTAL

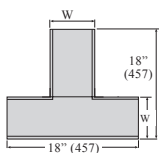

TH SV - 03 - FV



MATERIAL/MATERIAL
FV= FIBRA DE VIDRIO/
FV= FIBERGLASS
ANCHO / WIDTH
SV =SOLIDO / SOLID
CV = VENTILADO/VENTILATED
HORIZONTAL "T"
HORIZONTAL "T"

HORIZONTAL "T"

Ancho de Canaleta Canal Width	No. de Catalogo Tipo Liso Catalog Number Flat Type	No. de Catalogo Tipo ventilado Catalog Number ventileted Type
	Radio - 12" (306 mm)	Radio - 12" (306 mm)
3" (76 mm)	THSV-03R12-90-FV	THCV-03R12-90-FV
4" (102 mm)	THSV-04R12-90-FV	THCV-04R12-90-FV
6" (152 mm)	THSV-06R12-90-FV	THCV-06R12-90-FV
8" (203 mm)	THSV-08R12-90-FV	THCV-08R12-90-FV

PUEDER SER SUJETO A MODIFICACION SIN PREVIO AVISO
MAYBE SUBJECT TO MODIFICATION WITHOUT NOTICE

ACCESORIOS PARA CANALETA DE FIBRA DE VIDRIO

FITTINGS FOR FIBERGLASS CANAL

"K" HORIZONTAL

HORIZONTAL "K"

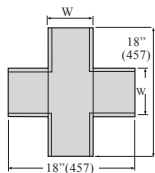

XH SV - 03 - FV

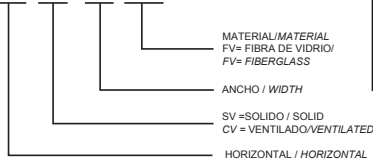

Ancho de Canaleta Canal Width	No. de Catalogo Catalog Number	No. de Catalogo Catalog Number
	Tipo Liso Flat Type	Tipo ventilado / ventilated Type
3" (76 mm)	XHSV-03-FV	XHCV-03-FV
4" (102 mm)	XHSV-04-FV	XHCV-04-FV
6" (152 mm)	XHSV-06-FV	XHCV-06-FV
8" (203 mm)	XHSV-08-FV	XHCV-08-FV

TAPA PLANA

FLAT TOP

Ancho de Canaleta Canal Width	No. de Catalogo Catalog Number	No. de Catalogo Catalog Number
	Tipo Liso Flat Type	Tipo ventilado / ventilated Type
3" (76 mm)	TRCHSV-03-FV	TRCHCV-03-FV
4" (102 mm)	TRCHSV-04-FV	TRCHCV-04-FV
6" (152 mm)	TRCHSV-06-FV	TRCHCV-06-FV
8" (203 mm)	TRCHSV-08-FV	TRCHCV-08-FV

TR CH SV - 03 - FV

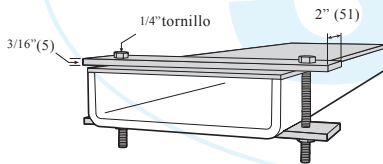
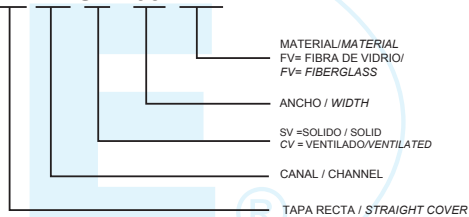

CONECTOR RECTO

STRAIGHT CONNECTOR

Ancho de Canaleta Canal Width	No. de Catalogo Catalog Number	No. de Catalogo Catalog Number
	Tipo Liso Flat Type	Tipo ventilado / ventilated Type
3" (76 mm)	ARSV-03-FV	ARCV-03-FV
4" (102 mm)	ARSV-04-FV	ARCV-04-FV
6" (152 mm)	ARSV-06-FV	ARCV-06-FV
8" (203 mm)	ARSV-08-FV	ARCV-08-FV

AR SV - 03 - FV

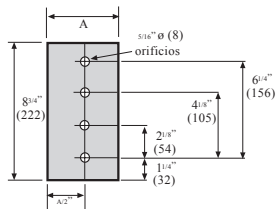
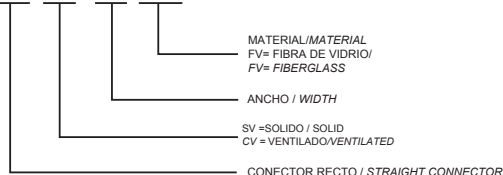

PUEDER SER SUJETO A MODIFICACION SIN PREVIO AVISO / MAYBE SUBJECT TO MODIFICATION WITHOUT NOTICE

SISTEMA DE SOPORTERIA Y UNICANAL DE FIBRA DE VIDRIO

ESPECIFICACIONES

- 1.0 **Alcance**
- 1.1 Esta especificación cubre los requerimientos para los sistemas de perfil unicanal y sus accesorios
- 2.0 **Normas**
- 2.1 Todo el unicanal tendrá un rango de extensión máxima de flama ≤ 25 , y el índice de desarrollo de la densidad de humo será ≤ 450 , al probarse de acuerdo con lo previsto por de ASTM E-84; por lo tanto, calificará como material clase 1 en el código de Edificio Uniforme.
- 2.2 Todo el unicanal actuará como inhibidor de luz UV adicional en el sistema de resina para protegerlo contra la degradación de los rayos ultravioleta.
- 3.0 **Materiales**
- 3.1 Todo el unicanal será fabricado por el proceso de pultrusión, con un contenido mínimo de fibra de vidrio de 50% del peso.
- 3.2 Todo el unicanal deberá ser conforme a las cargas y deflexiones mostradas en la siguiente tabla, como requerimiento mínimo.
- 4.0 **Abrazadera para Tubo No Metálica**
- 4.1 Todas las abrazaderas no metálicas para tubo serán fabricadas por el proceso de moldeo por inyección con impacto modificado, con 30% de relleno de resina de fibra de vidrio de poliéster termoplástico.
- 4.2 Todas las abrazaderas para tubo deberán enganchar con el perfil unicanal tal y como se muestra arriba.
- 4.3 Todas las abrazaderas para tubo deberán estar diseñadas para tubería de acero rígido con recubrimiento de PVC, tubería de PVC cédula 40 y 80, y tubería en fibra de vidrio o conduit. Las abrazaderas deberán ajustarse para aceptar una desviación mínima de 1/4" en la medida del diámetro exterior.
- 5.0 **Tornillería**
- 5.1 Toda la tornillería deberá ser acero inoxidable tipo 316 y tuercas de viniléster fabricado por moldeo a presión

INFORMACION TECNICA

Carga para Canal Perfil "U"

Datos de Viga y Columna: Base Resina de Poliéster y Viniléster

Tramo de Viga o Altura de Columna Pulg. (mm)	No. de Catalogo	Carga Uniforme Máxima Permitida en Viga		Deflexión en Carga Uniforme Máxima Permitida en Viga		Carga Uniforme en Deflexión Máxima = 0.25 In. (6mm)		Carga Uniforme en Deflexión Máxima = 0.50 In. (13mm)		Carga Máx. Permitida en Columna Lbs.(kg)
		Poliéster Lbs.(kg)	Viniléster Lbs.(kg)	Poliéster Lbs.(kg)	Viniléster Lbs.(kg)	Poliéster Lbs.(kg)	Viniléster Lbs.(kg)	Poliéster Lbs.(kg)	Viniléster Lbs.(kg)	
12" (305)	LU-1000FV	1720 (780)	2150 (975)	0.07 (2)	0.07 (2)	-	-	-	-	3650 (1655)
18" (457)	LU-1000FV	1150 (521)	1440 (653)	0.15 (4)	0.17 (4)	-	-	-	-	3370 (1528)
24" (610)	LU-1000FV	860 (390)	1080 (490)	0.27 (7)	0.30 (8)	810 (367)	910 (412)	-	-	2960 (1342)
30" (762)	LU-1000FV	690 (313)	870 (394)	0.42 (11)	0.48 (12)	410 (186)	460 (209)	-	-	2450 (1111)
36" (914)	LU-1000FV	580 (263)	730 (331)	0.61 (15)	0.69 (19)	240 (109)	270 (122)	450 (217)	540 (245)	1800 (816)
42" (1067)	LU-1000FV	490 (222)	620 (281)	0.82 (21)	0.92 (23)	150(68)	170 (77)	300 (136)	340 (154)	1320 (595)
48" (1219)	LU-1000FV	430 (195)	540 (245)	1.07 (27)	1.20 (30)	100 (45)	115 (52)	200 (90)	230 (104)	1010 (458)
60" (1524)	LU-1000FV	350 (158)	400 (200)	1.70 (43)	1.91 (48)	60 (27)	70 (32)	120 (54)	135 (61)	260 (118)
72" (1829)	LU-1000FV	290 (131)	370 (168)	2.44 (62)	2.78 (71)	30 (13)	34 (15)	60 (27)	70 (32)	-
84" (2134)	LU-1000FV	250 (113)	320 (145)	-	-	20 (9)	23 (10)	40 (18)	45 (20)	-
96" (2438)	LU-1000FV	220 (100)	250 (113)	-	-	13 (6)	15 (7)	26 (12)	30 (13)	-

* Deflexión esta en exceso de 3" (76mm): se recomienda un soporte a la mitad del tramo NR=No Recomendado; Cargas en Viga: La tabla muestra la carga total permitida basado en varios tramos simples con un factor de seguridad mín. de 2:1 Si se concentra la carga al centro del tramo, multiplica la carga de la tabla por 0.5 y la deflexión correspondiente por 0.8. Cargas en Columna: La tabla muestra la carga axial total permitida para varias alturas en columnas no soportadas, con un factor de seguridad mín. de 3:1 Las cargas excentricas serán reducidas de acuerdo a practicas normadas Nota: Las vigas se soportarán buscando prevenir la rotación del soporte. Vigas largas y profundas deberán estar amarradas entre los soportes para prevenir que se tuercen.

PUEDA SER SUJETO A MODIFICACION SIN PREVIO AVISO

FIBERGLASS STRUT SUPPORTS SYSTEM

SPECIFICATIONS

- 1.0 **Scope**
 - 1.1 This specification covers the requirements for strut profile systems and accessories.
- 2.0 **Standards**
 - 2.1 All the strut will have a range of maximum flame spread <25, and the rate of development of smoke density will be <450, when tested in accordance with the provided of ASTM-84, therefore, qualify as class materials 1 in the Uniform Building Code.
 - 2.2 All strut act as additional UV inhibitor in the resin system to protect against UV degradation.
- 3.0 **Materials**
 - 3.1 All the strut will be manufactured by the process of pultrusion, with a minimum fiberglass content of 50% by weight.
 - 3.2 All strut should conform to the loads and deflections shown in the table below, as a minimum requirement
- 4.0 **Non-metallic Tube Clamp**
 - 4.1 All non-metallic tube clamps will be manufactured by the injection molding process with impact modified with 30% filled with fiberglass thermoplastic polyester resin.
 - 4.2 All tube clamps will engage with the strut profile as show above
 - 4.3 All tube clamps should be designed for rigid steel tubering with PVC, PVC tubering schedule 40 and 80, and fiberglass or conduit tubering. The clamps should be adjusted to accept a minimum deviation of 1/4 in the measure of outside angle.
- 5.0 **Hardware**
 - 5.1 All hardware must be stainless steel type 316 and Vinylester screws manufactured by injection molding.

TECHNICAL INFORMATION

Load for Channel Profile "U"
Girder and column data: Base Polyester resin and Vinylester

Section of gired or height column in. Pulg. (mm)	Catalogo Number	Maximum Uniform load allowed on girder		Maximum Deflection uniform load allowed in girder		Maximum Uniform load in deflection = 0.25 In. (6mm)		Maximum Uniform load in deflection = 0.50 In. (13mm)		Maximum load allowed in column Lbs.(kg)
		Polyester Lbs.(kg)	Vinylester Lbs.(kg)	Polyester Lbs.(kg)	Vinylester Lbs.(kg)	Polyester Lbs.(kg)	Vinylester Lbs.(kg)	Polyester Lbs.(kg)	Vinylester Lbs.(kg)	
12" (305)	LU-1000FV	1720 (780)	2150 (975)	0.07 (2)	0.07 (2)	-	-	-	-	3650 (1655)
18" (457)	LU-1000FV	1150 (521)	1440 (653)	0.15 (4)	0.17 (4)	-	-	-	-	3370 (1528)
24" (610)	LU-1000FV	860 (390)	1080 (490)	0.27 (7)	0.30 (8)	810 (367)	910 (412)	-	-	2960 (1342)
30" (762)	LU-1000FV	690 (313)	870 (394)	0.42 (11)	0.48 (12)	410 (186)	460 (209)	-	-	2450 (1111)
36" (914)	LU-1000FV	580 (263)	730 (331)	0.61 (15)	0.69 (19)	240 (109)	270 (122)	450 (217)	540 (245)	1800 (816)
42" (1067)	LU-1000FV	490 (222)	620 (281)	0.82 (21)	0.92 (23)	150(68)	170 (77)	300 (136)	340 (154)	1320 (595)
48" (1219)	LU-1000FV	430 (195)	540 (245)	1.07 (27)	1.20 (30)	100 (45)	115 (52)	200 (90)	230 (104)	1010 (458)
60" (1524)	LU-1000FV	350 (158)	400 (200)	1.70 (43)	1.91 (48)	60 (27)	70 (32)	120 (54)	135 (61)	260 (118)
72" (1829)	LU-1000FV	290 (131)	370 (168)	2.44 (62)	2.78 (71)	30 (13)	34 (15)	60 (27)	70 (32)	-
84" (2134)	LU-1000FV	250 (113)	320 (145)	-	-	20 (9)	23 (10)	40 (18)	45 (20)	-
96" (2438)	LU-1000FV	220 (100)	250 (113)	-	-	13 (6)	15 (7)	26 (12)	30 (13)	-

* Deflection is in excess of 3 "(76mm): a support is recommended for mid section NR = Not recommended: The Table I shows the total allowable load based on several simple sections with a safety factor Min From 2.1 if the load concentrated in the centrum section, multiply load from the table by 0.5 and corresponding deflection by 0.8. Loads column: the table shows the total axial load allowed for various heights in columns not supported. With a safety factor min. 3.1 Eccentric loads will be reduced according to normed practices Note: The girded will support seeking to prevent rotation of the support. Long and deep girged should be tied between supports to prevent that crooked.

MAYBE SUBJECT TO MODIFICATION WITHOUT NOTICE

INSTALACIONES TÍPICAS

TYPICAL INSTALLATIONS

El unical de fibra de vidrio de SOPORTES ELECTRICOS combinado con nuestros accesorios de charola portacable son funcionales en muchas aplicaciones de charola/bandejas. SOPORTES ELECTRICOS fabrica todas las partes necesarias para elaborar en campo tus especificaciones, ya sea montajes en pared, piso o techo. SOPORTES ELECTRICOS también puede apoyarte en la ingeniería en base a tus requerimientos.

The fiberglass strut SOPORTES ELÉCTRICOS combined with our tray accessories holding cables are functional in many applications trays. SOPORTES ELÉCTRICOS manufactures all the necessary parts to develop in field your specification either wall mounts, floor or ceiling, SOPORTES ELÉCTRICOS can also support you on engineering based on your requirements.

**Anaqueles para Soporte de Tubería
Shelf for tubing support**

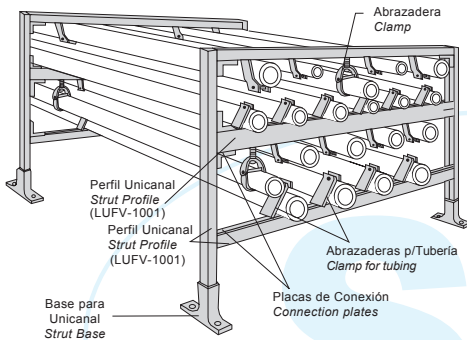

**Instalación en Pared Tipo Poste
Wall installation type post**

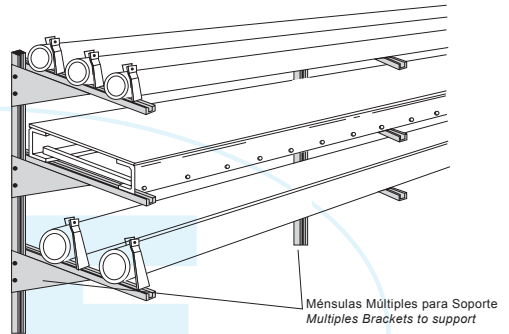

TRAMOS RECTOS "UNICAL DE FIBRA DE VIDRIO"

FIBERGLASS STRUT STRAIGHT SECTION

**UNICAL LUVF-1000 Y COMBINACIONES
LUVF-1000 STRUT AND COMBINATIONS**

NUMERO DE CATALOGO CATALOG NUMBER	PROFUNDIDAD DEPT A mm (Pulg)
LU-1000FV	41.3 (1.625)

LONGITUD : 3.05 m (10')
LENGHT : 3.05 m (10')

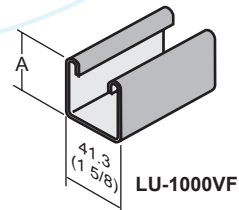

**PRLU-1000FV
UNICAL CON PERFORADO REDONDO.
ROUND HOLE STRUT**

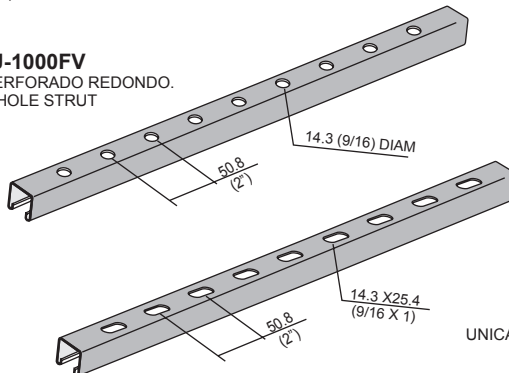

**PSLU-1000FV
UNICAL CON PERFORADO TIPO SLOT.
SLOTTED STRUT**

PUEDEN SER SUJETOS A MODIFICACION SIN PREVIO AVISO / MAYBE SUBJECT TO MODIFICATION WITHOUT NOTICE

ACCESORIOS DE ENSAMBLE: "UNICANAL DE FIBRA DE VIDRIO"

CONEXIONES DE CHAPA PLANA

PARA UNICANAL

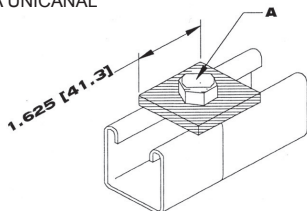

LU-1064FV
 CONECTOR DE EMPALME
 1 ORIFICIO
 ONE HOLE SPLICE PLATE

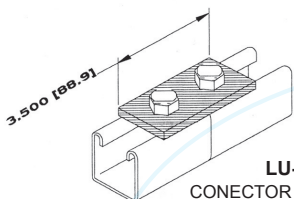

LU-1065FV
 CONECTOR DE EMPALME
 2 ORIFICIOS
 TWO HOLES SPLICE PLATE

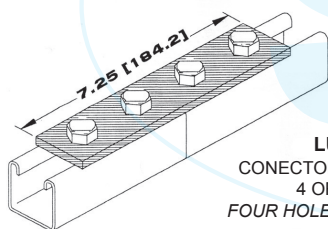

LU-1067FV
 CONECTOR DE EMPALME
 4 ORIFICIOS
 FOUR HOLES SPLICE PLATE

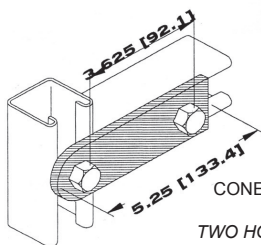

LU-2325FV
 CONECTOR GIRATORIO
 2 ORIFICIOS
 TWO HOLES SWIVEL PLATE

FLAT PLATE FITTINGS

FOR STRUT

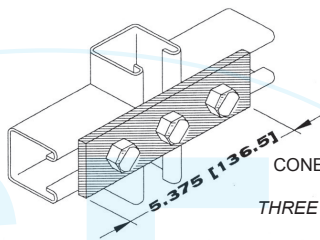

LU-1066FV
 CONECTOR DE EMPALME
 3 ORIFICIOS
 THREE HOLES SPLICE PLATE

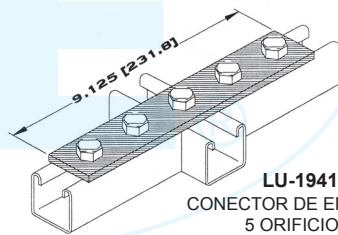

LU-1941FV
 CONECTOR DE EMPALME
 5 ORIFICIOS
 FIVE HOLES SPLICE PLATE

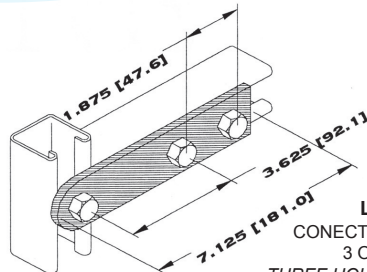

LU-2324FV
 CONECTOR GIRATORIO
 3 ORIFICIOS
 THREE HOLES SWIVEL PLATE

ESPECIFICACIONES (SPECIFICATIONS)

DIAMETRO DE ORIFICIO (HOLE SIZE): 14.3 (0,562)

ESPACIAMIENTO DEL CENTRO DEL ORIFICIO EXTREMO (HOLE SPACING): 20.6(0,812)

ESPACIAMIENTO ENTRE CENTROS DE ORIFICIO (HOLE SPACING): 47.6(1,875)

DIMENSIONES EN PULG. (mm)

PUEDO SER SUJETO A MODIFICACION SIN PREVIO AVISO / MAYBE SUBJECT TO MODIFICATION WITHOUT NOTICE

CONEXIONES DE CHAPA PLANA

PARA UNICANAL

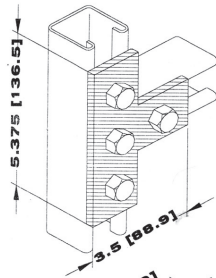

LU-1031FV
CONECTOR "T"
4 ORIFICIOS
FOUR HOLE TEE PLATE

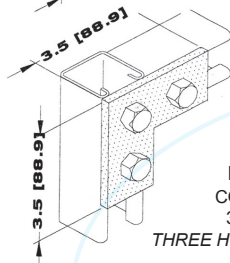

LU-1036FV
CONECTOR "L"
3 ORIFICIOS
THREE HOLE CORNER PLATE

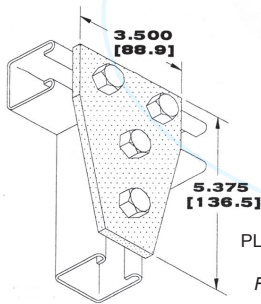

LU-1358FV
PLACA CONECTORA
4 ORIFICIOS
FOUR HOLE TEE
GUSSET PLATE

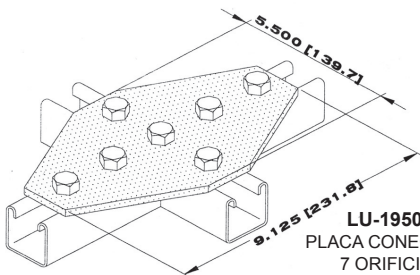

LU-1950FV
PLACA CONECTORA
7 ORIFICIOS
SEVEN HOLE CROSS
GUSSET PLATE

FLAT PLATE FITTINGS

FOR STRUT

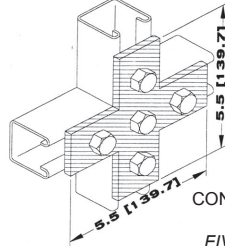

LU-1028FV
CONECTOR DE CRUZ
5 ORIFICIOS
FIVE HOLE CROSS
PLATE

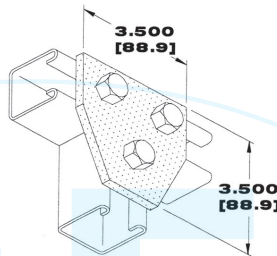

LU-1356FV
PLACA CONECTORA
3 ORIFICIOS
THREE HOLE GUSSET PLATE

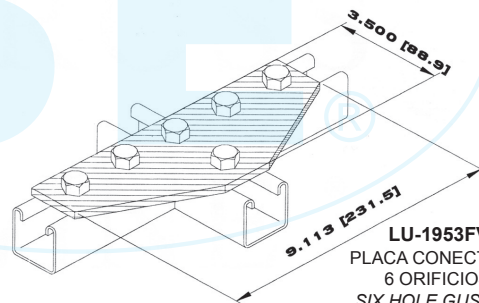

LU-1953FV
PLACA CONECTORA
6 ORIFICIOS
SIX HOLE GUSSET
PLATE

ESPECIFICACIONES (SPECIFICATIONS)

DIAMETRO DE ORIFICIO (HOLE SIZE): 14.3 (0,562)
ESPACIAMIENTO DEL CENTRO DE ORIFICIO AL
EXTREMO (HOLE SPACING): 20.6(0,812)
ESPACIAMIENTO ENTRE CENTROS
DE ORIFICIOS (HOLE SPACING): 47.6(1,875)
DIMENSIONES EN PULG. (mm)

PUEDA SER SUJETO A MODIFICACION SIN PREVIO AVISO / MAYBE SUBJECT TO MODIFICATION WITHOUT NOTICE

CONEXIONES ANGULARES DE 90°

90° ANGULAR FITTINGS

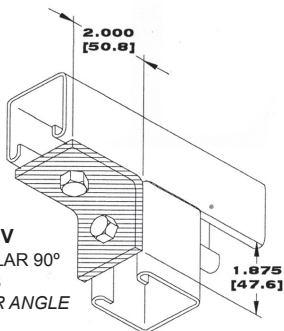

LU-1026FV
 CONECTOR ANGULAR 90°
 2 ORIFICIOS
 TWO HOLE CORNER ANGLE

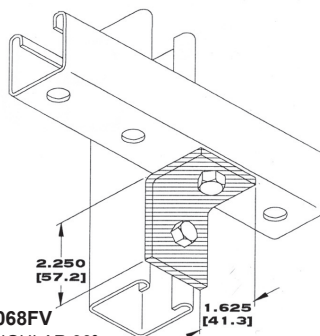

LU-1068FV
 CONECTOR ANGULAR 90°
 2 ORIFICIOS
 TWO HOLE CORNER ANGLE

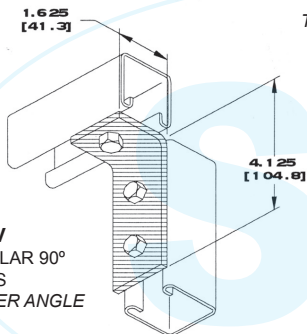

LU-1326FV
 CONECTOR ANGULAR 90°
 3 ORIFICIOS
 THREE HOLE CORNER ANGLE

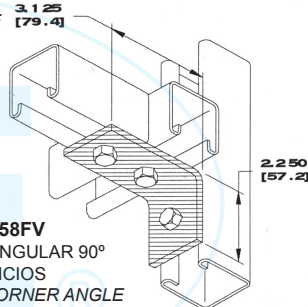

LU-1458FV
 CONECTOR ANGULAR 90°
 3 ORIFICIOS
 THREE HOLE CORNER ANGLE

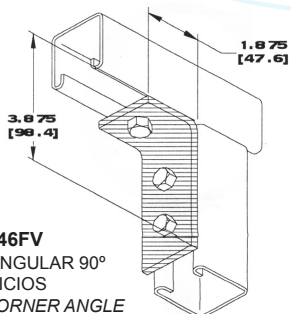

LU-1346FV
 CONECTOR ANGULAR 90°
 3 ORIFICIOS
 THREE HOLE CORNER ANGLE

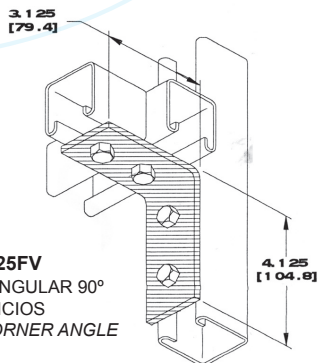

LU-1325FV
 CONECTOR ANGULAR 90°
 4 ORIFICIOS
 FOUR HOLE CORNER ANGLE

ESPECIFICACIONES (SPECIFICATIONS)

DIAMETRO DE ORIFICIO (HOLE SIZE): 14.3 (0,562)
 ESPACIAMIENTO DEL CENTRO DE ORIFICIO EXTREMO (HOLE SPACING): 20.6(0,812)
 ESPACIAMIENTO ENTRE CENTRO DE ORIFICIOS (HOLE SPACING): 47.6(1,875)
 DIMENSIONES EN PULG. (mm)

PUEDE SER SUJETO A MODIFICACION SIN PREVIO AVISO / MAYBE SUBJECT TO MODIFICATION WITHOUT NOTICE

CONEXIONES ANGULARES DE 90°

90° ANGULAR FITTINGS

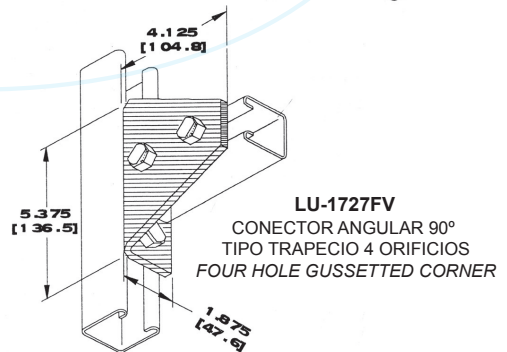
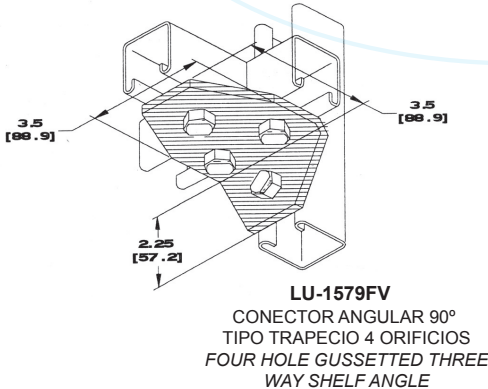
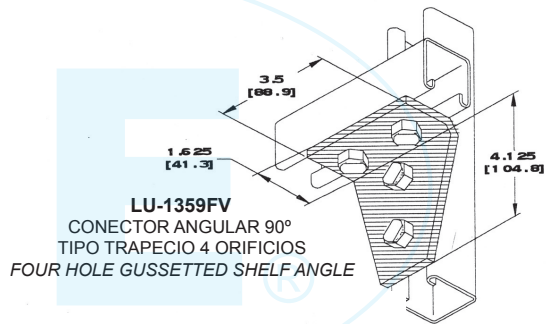
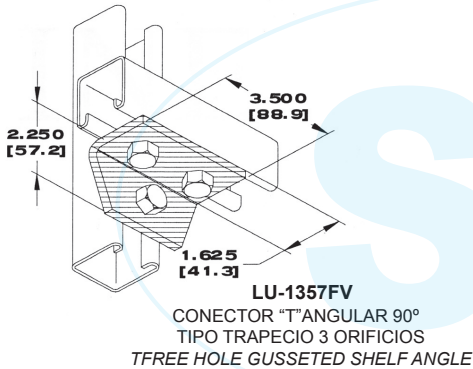
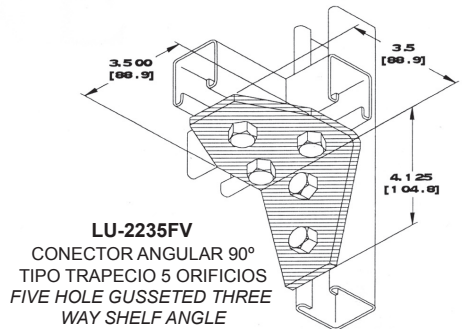
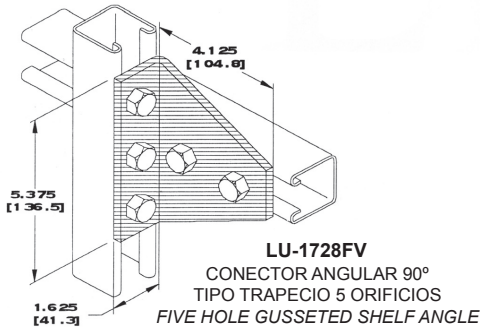

ESPECIFICACIONES (SPECIFICATIONS)

DIAMETRO DE ORIFICIO (HOLE SIZE): 14.3 (0,562)

ESPACIAMIENTO DEL CENTRO DE ORIFICIO AL EXTREMO (HOLE SPACING): 20.6(0,812)

ESPACIAMIENTO ENTRE CENTRO DE ORIFICIOS (HOLE SPACING): 47.6(1,875)

DIMENSIONES EN PULG. (mm)

PUEDEN SER SUJETOS A MODIFICACION SIN PREVIO AVISO / MAYBE SUBJECT TO MODIFICATION WITHOUT NOTICE

ACCESORIOS DE MONTAJE "UNICANAL DE FIBRA DE VIDRIO"

MOUNTING ACCESSORIES "FIBERGLASS STRUT"

ABRAZADERA PARA TUBO CONDUIT: "UNICANAL DE FIBRA DE VIDRIO"

MOUNTING ACCESSORIES "FIBERGLASS STRUT"

No. de Catalogo Catalog Number	Medida Tubo Pulg. Measure tube inch	Peso/Weight 100 Jgs* lbs.	PVC Cedula 40 y 80 PVC warrant 40 and 80	Acero Rec. con PVC Steel rec. PVC	Acero Rigido Rigid Steel	Fibra de Vidrio (FRP) Fiberglass (FRP)
LU-1111FV	1/2	9.0	.0840	0.920	.0840	-
LU-1112FV	3/4	10.0	1.050	1.130	1.050	0.980
LU-1113FV	1	10.5	1.315	1.395	1.315	1.195
LU-1114FV	1 1/4	11.0	1.660	1.740	1.660	1.507
LU-1115FV	1 1/2	13.02	1.900	1.980	1.900	1.757
LU-1117FV	2	14.0	2.375	2.455	2.375	2.132
LU-1118FV	2 1/2	18.0	2.875	2.955	2.875	2.650
LU-1119FV	3	20.0	3.500	3.580	3.500	3.132
LU-1120FV	3 1/2	23.0	4.000	4.080	4.000	3.632
LU-1121FV	4	25.0	4.500	4.580	4.500	4.132

TUERCA EN FRP PARA UNICANAL DE FIBRA DE VIDRIO

FRP NUT FOR FIBERGLASS STRUT

No. de Catalogo Catalog Number	Rosca Thread	Peso Weight	Espesor Thickness
LU-3008FV	3/8"-16UNC	5.4 Lbs/c	1 1/16"(27)
LU-3010FV	1/2"-13UNC	5.0 Lbs/c	1 1/16"(27)

El estándar es en resina de viniléster. Las tuercas para unicanal se aseguran por si solas. Resistencia al deslizamiento = 450 lbs. por tornillo. Resistencia al retirarla = 700 lbs. por tornillo. The standard in this Vinyl ester Resin. The nuts are secured for themselves Slip resistance = 450 lbs. Screw Resistance to remove = 700 lbs. Screw



Diagrama: Tuercas con Clema de Sujeción
Diagram: Nut subsection clamp

*Incluye tornillo de acero Inoxidable
* Includes stainless steel screw

Para tubo rígido, acerorecubierta con PVC, PVC Cédula 40 & 80 y conduit en fibra de vidrio.

Elaborada con resina de poliéster de fibra de vidrio termoplástica con un alto grado de endurecimiento, recomendada para la instalación horizontal únicamente (tal como se muestra).

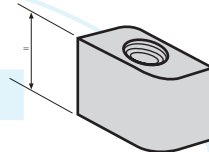
For rigid tube, steel covered with PVC, PVC Warrant 40 & 80 and fiberglass conduit.

Made with Polyester Resin Fiberglass Teroplastic with a high degree of hardening Recommended for horizontal installation only (as show)

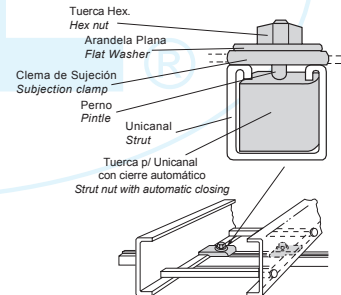
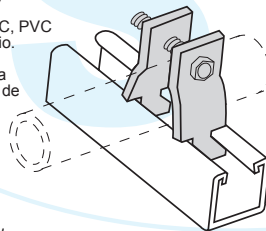

MORDAZA DE VIGA PARA UNICANAL DE FIBRA DE VIDRIO

BEAM CLAMP FOR FIBERGLASS STRUT

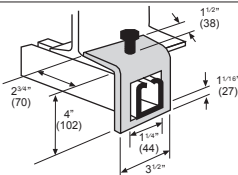

LU-1796SFV

MORDAZA DE VIGA TIPO INSERCIÓN APLICABLES PARA VIGAS CON ESPESORES DE 22.2 mm Y MENORES
CLAMP TYPE BEAM WITH INSERT APPLICABLE 22.2 mm THICKNESS AND UNDER

CADA MORDAZA INCLUYE TORNILO DE CABEZA HEXAGONAL DE ACERO INOXIDABLE SE DEBE UTILIZAR EN PARES
EACH CLAMP INCLUDES HEX HEAD SCREW STAINLESS STEEL MUST BE USED IN PAIRS.

PUEDEN SER SUJETOS A MODIFICACION SIN PREVIO AVISO / MAYBE SUBJECT TO MODIFICATION WITHOUT NOTICE

BASE PARA POSTE DE UNICANAL DE FIBRA DE VIDRIO

BASE FOR POST FIBERGLASS STRUT

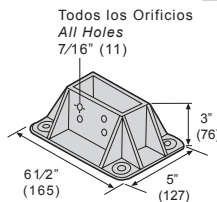

LU-2072 AFV

BASE REFORZADA PARA POSTE UNICANAL LUVF-1000 1
REINFORCED BASE FOR STRUT POST LUVF-1000 1

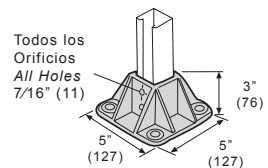

LU-2072FV

BASE REFORZADA PARA POSTE UNICANAL LUVF-1000
REINFORCED BASE FOR STRUT POST LUVF-1000

PRODUCTOS SOPORTES ELECTRICOS

MORDAZA DE VIGA PARA USARSE CON VARILLA ROSCADA EN FIBRA DE VIDRIO

No. de Catalogo Catalog Number	Descripción Description
LU2676-38FV	Sencilla p/varilla roscada FRP de 3/8" Single FRP threaded rod 3/8"
LU2676-12FV	Sencilla p/varilla roscada FRP de 1/2" Single FRP threaded rod 1/2"
LU2676-58FV	Sencilla p/varilla roscada FRP de 5/8" Single FRP threaded rod 5/8"
LU2676-34FV	Sencilla p/varilla roscada FRP de 3/4" Single FRP threaded rod 3/4"

BEAM CLAMP FOR USE WITH THREADED ROD FIBERGLASS

Carga Ultima = 300 Lbs
Factor de seguridad recomendado = 3
Incluye tornillo en acero inoxidable en la parte superior de la abrazadera
Last load = 300lbs.
Recommended Safety Factor = 3
Stainless steel screw includes in the top of the clamp.

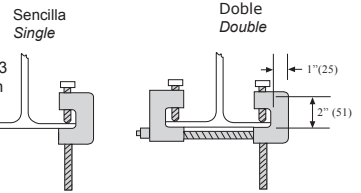

VARILLA ROSCADA EN FIBRA DE VIDRIO

No. de Catalogo Catalog Number	Medida Measure	Peso Weight
VR-38FV	3/8" -16	0.07 Lbs/Ft
VR-12FV	1/2" -13	0.12 Lbs/Ft
VR-58FV	5/8" -11	0.18 Lbs/Ft
VR-34FV	3/4" -10	0.28 Lbs/Ft
VR-100FV	1" -8	0.50 Lbs/Ft

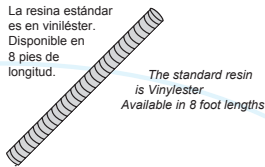

FIBERGLASS-THREADED ROD

TUERCA HEXAGONAL EN FIBRA DE VIDRIO

No. de Catalogo Catalog Number	Medida Measure	Peso Weight	t	A
TCHA-38FV	3/8" -16	2.43 Lbs/C	3/8" (16)	7/8" (22)
TCHA-12FV	1/2" -13	2.17 Lbs/C	3/8" (16)	7/8" (22)
TCHA-58FV	5/8" -11	6.05 Lbs/C	7/8" (22)	1 1/4" (32)
TCHA-34FV	3/4" -10	5.42 Lbs/C	7/8" (22)	1 1/4" (32)
TCHA-100FV	1" -8	20.49 Lbs/C	1 1/4" (32)	2" (51)



La resina estándar es en viniléster
The standard resin is vinyl ester.

HEXAGONAL NUT IN FIBERGLASS

ARANDELA PLANA EN FIBRA DE VIDRIO

No. de Catalogo Catalog Number	Medida Measure	Peso Weight
ROP-38FV	3/8" -16	1.3 Lbs/c
ROP-12FV	1/2" -13	1.3 Lbs/c
ROP-58FV	5/8" -11	1.3 Lbs/c
ROP-34FV	3/4" -10	1.3 Lbs/c
ROP-100FV	1" -8	1.3 Lbs/c

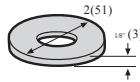

WASHER FLAT IN FIBERGLASS

COPE PARA VARILLA ROSCADA FIBRA DE VIDRIO

No. de Catalogo Catalog Number	Medida Measure	Peso Weight	t
CVR-38FV	3/8" -16	7.80 Lbs/C	2" (51)
CVR-12FV	1/2" -13	7.00 Lbs/C	2" (51)
CVR-58FV	5/8" -11	13.73 Lbs/C	2" (51)
CVR-34FV	3/4" -10	12.66 Lbs/C	2" (51)
CVR-100FV	1" -8	44.03 Lbs/C	2 3/4" (70)

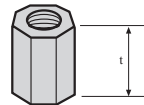

La resina estándar es en viniléster.
IMPORTANTE: El agarre mínimo de cuerda debe ser de 3/4" por lado.
The standard resin is Vinylester
IMPORTANT: The minimum grip rope should be 3/4" per side.

PUEDA SER SUJETO A MODIFICACION SIN PREVIO AVISO / MAYBE SUBJECT TO MODIFICATION WITHOUT NOTICE

SECCION 1.1 SOPORTERIA PARA CABLES TIPO ESCALERA

SECTION 1.1 CABLE TRAY SYSTEM LADDER TYPE



SECCIONES TIPO "Z"

PERALTE NOMINAL SIDE RAIL HEIGHT	PERALTE UTIL LOADING DEPTH	PERFIL TIPO RAIL TYPE	SUBFIJO P/PERALTE RAIL HEIGHT SUFFIX	CLASE NEMA NEMA CLASS	
				ALUMINIO ALUMINUM	ACERO STEEL
82.5 (3.25)	58.1 (2.22)	Z	1	8A	8A
82.5 (3.25)	56.5 (2.22)	Z	1	8C/12A	12B
101.6 (4)	75.6 (2.98)	Z	2	8C/12A	12C
101.6 (4)	75.6 (2.98)	Z	2	12B	12C
114.3 (4.5)	88.3 (3.48)	Z	3	12B	12C
127.0 (5)	101.4 (3.98)	Z	5	12C	20A
152.4 (6)	126.4 (4.98)	Z	6	16C	20B

FORM "Z" SECTIONS

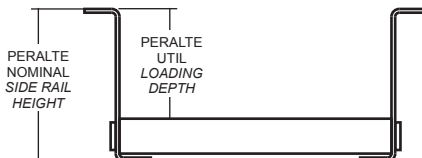

TYPE DATE SHOULD BE OMITED (ZA, ZB)

SECCIONES TIPO "C" CON CEJA HACIA ADENTRO

PERALTE NOMINAL SIDE RAIL HEIGHT	PERALTE UTIL LOADING DEPTH	PERFIL TIPO RAIL TYPE	SUBFIJO P/PERALTE RAIL HEIGHT SUFFIX	CLASE NEMA NEMA CLASS	
				ALUMINIO ALUMINUM	ACERO STEEL
82.5 (3.25)	56.5 (2.22)	C	1	8C/12A	12B
101.6 (4)	75.6 (2.98)	C	2	12B	12C
114.3 (4.5)	88.3 (3.48)	C	3	8C/12A	12C
127.0 (5)	101.4 (3.98)	C	5	8C/12A	16B
152.4 (6)	126.4 (4.98)	C	6	16C	20B
152.4 (6)	126.4 (4.98)	C	6	20C	20B

FORM "C" FLANGE IN SECTIONS

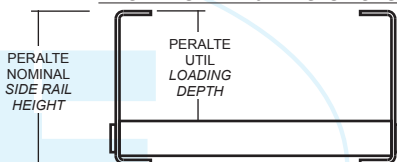

SECCIONES TIPO "I"

PERALTE NOMINAL SIDE RAIL HEIGHT	PERALTE UTIL LOADING DEPTH	PERFIL TIPO RAIL TYPE	SUBFIJO P/PERALTE RAIL HEIGHT SUFFIX	CLASE NEMA NEMA CLASS	
				ALUMINIO ALUMINUM	ACERO STEEL
101.6 (4)	75.6 (2.98)	IL	2	8C/12A	
101.6 (4)	75.6 (2.98)	IM	2	16C	
101.6 (4)	75.6 (2.98)	IP	2	20B	
152.4 (6)	126.4 (4.98)	IL	6	12B	
152.4 (6)	126.4 (4.98)	IP	6	20C	

FORM "I" SECTIONS

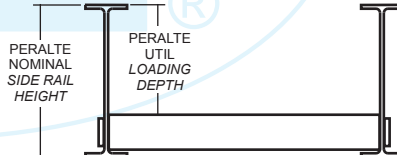

TODOS LOS ACCESORIOS EN PERFIL "I" SE FABRICAN EXTRUCTURAL / ALL THE ACCESSORIES IN PROFILE "I" ARE MANUFACTURED EXTRUCTURAL

PERFIL I SOLO EN ALUMINIO / FORM ALUMINUM ONLY

PERFIL I FABRICADO EN LIGERO, MEDIANO Y PESADO / PROFILE I MANUFACTURED IN LIGHT, MEDIUM AND HEAVY

MATERIALES Y ACABADOS DISPONIBLES:

- A: ALUMINIO ALEACION AA-6063 ACABADO NATURAL
- GI : ACERO AL CARBONO GALVANIZADO POR INMERSION EN CALIENTE SEGUN ASTM A 123
- GE : ACERO AL CARBONO GALVANIZADO ELECTROLITICO SEGUN ASTM B 633
- T : ACERO AL CARBONO TROPICALIZADO
- PVC: ACERO AL CARBONO RECUBIERTO CON PVC SEGUN NEMA RN 1
- PVA : ALUMINIO RECUBIERTO CON PVC SEGUN NEMA RN 1
- AI : ACERO INOXIDABLE ACABADO NATURAL
- G: ACERO GALVANIZADO

MATERIALS & FINISHES AVAILABLE :

- A: AA-6063 NATURAL FINISHED ALUMINUM
- GI : HOT DIP GALVANIZED STEEL UNDER ASTM A 123
- GE : ELECTROGALVANIZED STEEL UNDER ASTM B 633
- T : CHROMIUM-ZINC COATED STEEL
- PVC: PVC COATED STEEL UNDER NEMA RN 1
- PVA: PVC COATED ALUMINUM UNDER NEMA RN 1
- AI : NATURAL FINISHED STAINLESS STEEL
- G: GALVANIZED STEEL

PARA MATERIALES Y ACABADOS NO INDICADOS CONSULTE NUESTRO DEPARTAMENTO DE INGENIERIA FOR MATERIALS AND FINISHES NOT SHOWN, PLEASE CONSULT OUT TECHNICAL DEPARTMENT

TODAS LAS DIMENSIONES EN mm (Pulg) / ALL DIMENSIONS ARE IN mm (Inch)

PUEDEN SER SUJETOS A MODIFICACION SIN PREVIO AVISO / MAY BE SUBJECT TO MODIFICATION WITHOUT NOTICE



TRAMO RECTO

STRAIGHT SECTION

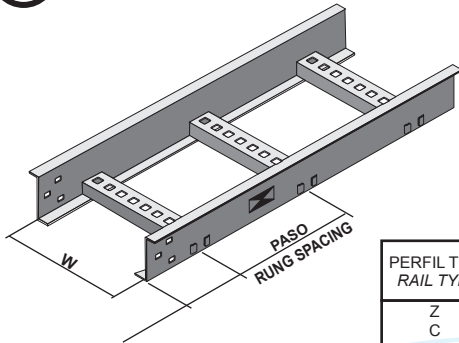

CH Z -12 09-1GI

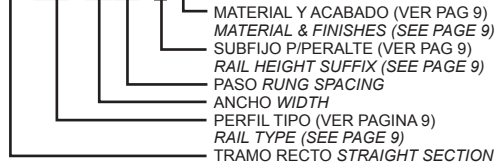

LONGITUDES ESTANDAR EN METROS (PIES)
STANDARD LENGTH IN METERS (FEET)

PERFIL TIPO RAIL TYPE	MATERIAL Y ACABADO VER PAGINA 9 MATERIAL AND FINISH SEE PAGE 9						
	A	GI	GE	T	PVC	PVA	AI
Z	3.66 (12)	3.66 (12)	3.66 (12)	3.66 (12)	3.05 (10)	3.05 (10)	3.66 (12)
C	3.66 (12)	3.66 (12)	3.66 (12)	3.66 (12)	3.05 (10)	3.05 (10)	3.66 (12)
	3.66 (12)					3.05 (10)	

PARA LONGITUDES DIFERENTES CONSULTE NUESTRO DEPARTAMENTO DE INGENIERIA
FOR OTHER LENGTH PLEASE CONSULT OUR TECHNICAL DEPARTMENT

ANCHO W WIDTH W	PASO RUNG SPACING			PASO RUNG SPACING		
	152.4 (6)	228.6 (9)	304.8 (12)	152.4 (6)	228.6 (9)	304.8 (12)
101.6 (4)	CHZ-0406	CHZ-0409	CHZ-0412	CHC-0406	CHC-0409	CHC-0412
152.4 (6)	CHZ-0606	CHZ-0609	CHZ-0612	CHC-0606	CHC-0609	CHC-0612
228.9 (9)	CHZ-0906	CHZ-0909	CHZ-0912	CHC-0906	CHC-0909	CHC-0912
304.8 (12)	CHZ-1206	CHZ-1209	CHZ-1212	CHC-1206	CHC-1209	CHC-1212
406.4 (16)	CHZ-1606	CHZ-1609	CHZ-1612	CHC-1606	CHC-1609	CHC-1612
457.2 (18)	CHZ-1806	CHZ-1809	CHZ-1812	CHC-1806	CHC-1809	CHC-1812
508.0 (20)	CHZ-2006	CHZ-2009	CHZ-2012	CHC-2006	CHC-2009	CHC-2012
609.6 (24)	CHZ-2406	CHZ-2409	CHZ-2412	CHC-2406	CHC-2409	CHC-2412
762.0 (30)	CHZ-3006	CHZ-3009	CHZ-3012	CHC-3006	CHC-3009	CHC-3012
914.4 (36)	CHZ-3606	CHZ-3609	CHZ-3612	CHC-3606	CHC-3609	CHC-3612

ANCHO W WIDTH W	PASO RUNG SPACING		
	152.4 (6)	228.6 (9)	304.8 (12)
101.6 (4)	CHI-0406	CHI-0409	CHI-0412
152.4 (6)	CHI-0606	CHI-0609	CHI-0612
228.9 (9)	CHI-0906	CHI-0909	CHI-0912
304.8 (12)	CHI-1206	CHI-1209	CHI-1212
406.4 (16)	CHI-1606	CHI-1609	CHI-1612
457.2 (18)	CHI-1806	CHI-1809	CHI-1812
508.0 (20)	CHI-2006	CHI-2009	CHI-2012
609.6 (24)	CHI-2406	CHI-2409	CHI-2412
762.0 (30)	CHI-3006	CHI-3009	CHI-3012
914.4 (36)	CHI-3606	CHI-3609	CHI-3612

INCLUYE 2 CONECTORES Y TORNILLERIA / TWO CONNECTOR AND HARDWARE INCLUDED
TODAS LAS DIMENSIONES EN mm (Pulg) / ALL DIMENSIONS ARE IN mm (Inch)

PUEDEN SER SUJETOS A MODIFICACION SIN PREVIO AVISO / MAY BE SUBJECT TO MODIFICATION WITHOUT NOTICE

CURVA HORIZONTAL A 45° Y 90°

DISEÑO RADIAL PARA PERFIL Z
RADIAL DESIGN FOR RAIL TYPE Z

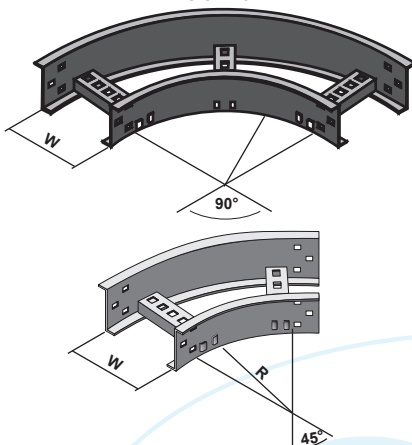

45° & 90° HORIZONTAL BEND

DISEÑO ESTRUCTURAL PARA PERFIL "Z", "C" E "I"
SEGMENTED DESIGN FOR RAIL TYPE "Z", "C" & "I"

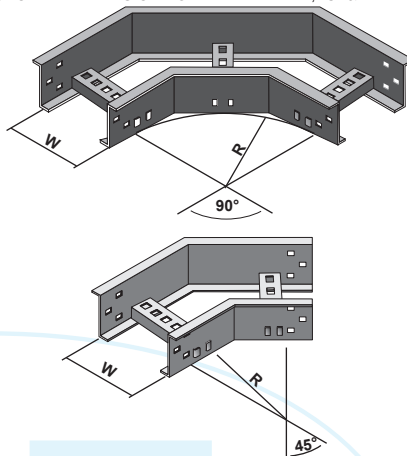

VH Z - 12R890-1GI E

- DISEÑO E = ESTRUCTURAL, EN CASO RADIAL OMITIR / DESIGN E = SEGMENTED, VOID IF RADIAL
- MATERIAL Y ACABADO (VER PAG 9) / MATERIAL & FINISHES (SEE PAGE 9)
- SUBFIJO P/PERALTE (VER PAG 9) / RAIL HEIGHT SUFFIX (SEE PAGE 9)
- ANGULO DE LA CURVA / ANGLE BEND
- RADIO RADIUS
- ANCHO WIDTH
- PERFIL TIPO (VER PAGINA 9) / RAIL TYPE (SEE PAGE 9)
- CURVA HORIZONTAL / HORIZONTAL BEND

NUMEROS DE CATALOGO PARA CURVA A 90° 90° BEND CATALOG NUMBER

ANCHO W WIDTH W	RADIO RADIUS			
	203.2 (8)	304.8 (12)	609.6 (24)	914.4 (36)
101.6 (4)	VH-04R890	VH-04R1290	VH-04R2490	VH-04R3690
152.4 (6)	VH-06R890	VH-06R1290	VH-06R2490	VH-06R3690
228.9 (9)	VH-09R890	VH-09R1290	VH-09R2490	VH-09R3690
304.8 (12)	VH-12R890	VH-12R1290	VH-12R2490	VH-12R3690
406.4 (16)	VH-16R890	VH-16R1290	VH-16R2490	VH-16R3690
457.2 (18)	VH-18R890	VH-18R1290	VH-18R2490	VH-18R3690
508.0 (20)	VH-20R890	VH-20R1290	VH-20R2490	VH-20R3690
609.6 (24)	VH-24R890	VH-24R1290	VH-24R2490	VH-24R3690
762.0 (30)	VH-30R890	VH-30R1290	VH-30R2490	VH-30R3690
914.4 (36)	VH-36R890	VH-36R1290	VH-36R2490	VH-36R3690

NUMEROS DE CATALOGO PARA CURVA A 45° 45° BEND CATALOG NUMBER

ANCHO W WIDTH W	RADIO RADIUS			
	203.2 (8)	304.8 (12)	609.6 (24)	914.4 (36)
101.6 (4)	VH-04R845	VH-04R1245	VH-04R2445	VH-04R3645
152.4 (6)	VH-06R845	VH-06R1245	VH-06R2445	VH-06R3645
228.9 (9)	VH-09R845	VH-09R1245	VH-09R2445	VH-09R3645
304.8 (12)	VH-12R845	VH-12R1245	VH-12R2445	VH-12R3645
406.4 (16)	VH-16R845	VH-16R1245	VH-16R2445	VH-16R3645
457.2 (18)	VH-18R845	VH-18R1245	VH-18R2445	VH-18R3645
508.0 (20)	VH-20R845	VH-20R1245	VH-20R2445	VH-20R3645
609.6 (24)	VH-24R845	VH-24R1245	VH-24R2445	VH-24R3645
762.0 (30)	VH-30R845	VH-30R1245	VH-30R2445	VH-30R3645
914.4 (36)	VH-36R845	VH-36R1245	VH-36R2445	VH-36R3645

INCLUDE 2 CONECTORES Y TORNILLERIA / TWO CONNECTORS AND HARDWARE INCLUDED

TODAS LAS DIMENSIONES EN mm (Pulg) / ALL DIMENSIONS ARE IN mm (Inch)

PUEDEN SER SUJETOS A MODIFICACION SIN PREVIO AVISO / MAY BE SUBJECT TO MODIFICATION WITHOUT NOTICE



CURVA VERTICAL EXTERIOR A 45° Y 90°

DISEÑO RADIAL PARA PERFIL Z
RADIAL DESIGN FOR RAIL TYPE Z

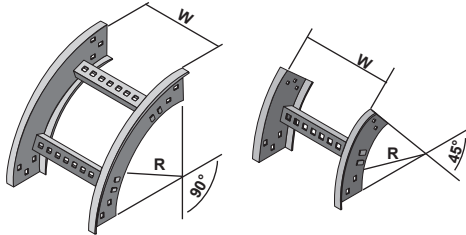

45° & 90° OUTSIDE VERTICAL BEND

DISEÑO ESTRUCTURAL PARA PERFIL "Z", "C" E "I"
SEGMENTED DESIGN FOR RAIL TYPE "Z", "C" & "I"

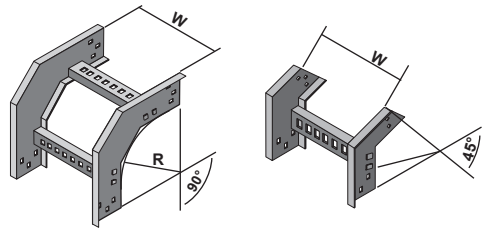

VE Z -12R8 90-1GI E

- DISEÑO E = ESTRUCTURAL, EN CASO RADIAL OMITIR / DESIGN E = SEGMENTED, VOID IF RADIAL
- MATERIAL Y ACABADO (VER PAG 9) / MATERIAL & FINISHES (SEE PAGE 9)
- SUBFIJO P/PERALTE (VER PAG 9) / RAIL HEIGHT SUFFIX (SEE PAGE 9)
- ANGULO DE LA CURVA (VER PAG 9) / ANGLE BEND
- RADIO RADIUS
- ANCHO WIDTH
- PERFIL TIPO (VER PAGINA 9) / RAIL TYPE (SEE PAGE 9)
- CURVA VERTICAL EXTERIOR / OUTSIDE VERTICAL BEND

NUMEROS DE CATALOGO PARA CURVA A 90° 90° BEND CATALOG NUMBER

ANCHO W WIDTH W	RADIO RADIUS			
	203.2 (8)	304.8 (12)	609.6 (24)	914.4 (36)
101.6 (4)	VE-04R890	VE-04R1290	VE-04R2490	VE-04R3690
152.4 (6)	VE-06R890	VE-06R1290	VE-06R2490	VE-06R3690
228.9 (9)	VE-09R890	VE-09R1290	VE-09R2490	VE-09R3690
304.8 (12)	VE-12R890	VE-12R1290	VE-12R2490	VE-12R3690
406.4 (16)	VE-16R890	VE-16R1290	VE-16R2490	VE-16R3690
457.2 (18)	VE-18R890	VE-18R1290	VE-18R2490	VE-18R3690
508.0 (20)	VE-20R890	VE-20R1290	VE-20R2490	VE-20R3690
609.6 (24)	VE-24R890	VE-24R1290	VE-24R2490	VE-24R3690
762.0 (30)	VE-30R890	VE-30R1290	VE-30R2490	VE-30R3690
914.4 (36)	VE-36R890	VE-36R1290	VE-36R2490	VE-36R3690

NUMEROS DE CATALOGO PARA CURVA A 45° 45° BEND CATALOG NUMBER

ANCHO W WIDTH W	RADIO RADIUS			
	203.2 (8)	304.8 (12)	609.6 (24)	914.4 (36)
101.6 (4)	VE-04R845	VE-04R1245	VE-04R2445	VE-04R3645
152.4 (6)	VE-06R845	VE-06R1245	VE-06R2445	VE-06R3645
228.9 (9)	VE-09R845	VE-09R1245	VE-09R2445	VE-09R3645
304.8 (12)	VE-12R845	VE-12R1245	VE-12R2445	VE-12R3645
406.4 (16)	VE-16R845	VE-16R1245	VE-16R2445	VE-16R3645
457.2 (18)	VE-18R845	VE-18R1245	VE-18R2445	VE-18R3645
508.0 (20)	VE-20R845	VE-20R1245	VE-20R2445	VE-20R3645
609.6 (24)	VE-24R845	VE-24R1245	VE-24R2445	VE-24R3645
762.0 (30)	VE-30R845	VE-30R1245	VE-30R2445	VE-30R3645
914.4 (36)	VE-36R845	VE-36R1245	VE-36R2445	VE-36R3645

INCLUYE 2 CONECTORES Y TORNILLERIA / TWO CONNECTORS AND HARDWARE INCLUDED

TODAS LAS DIMENSIONES EN mm (Pulg) / ALL DIMENSIONS ARE IN mm (Inch)

PUEDEN SER SUJETOS A MODIFICACION SIN PREVIO AVISO / MAY BE SUBJECT TO MODIFICATION WITHOUT NOTICE



CURVA VERTICAL INTERIOR A 45° Y 90°

DISEÑO RADIAL PARA PERFIL Z
RADIAL DESIGN FOR RAIL TYPE Z

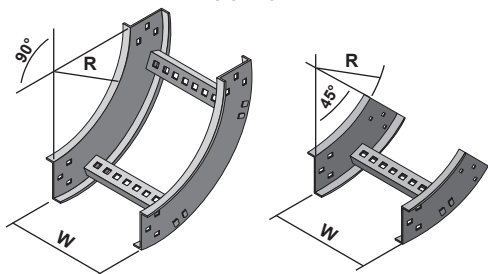

45° & 90° INSIDE VERTICAL BEND

DISEÑO ESTRUCTURAL PARA PERFIL "Z", "C" E "I"
SEGMENTED DESIGN FOR RAIL TYPE "Z", "C" & "I"

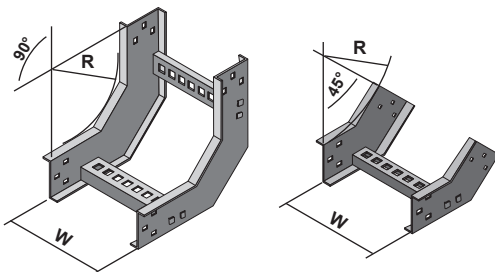

VI Z-12R890-1GI E

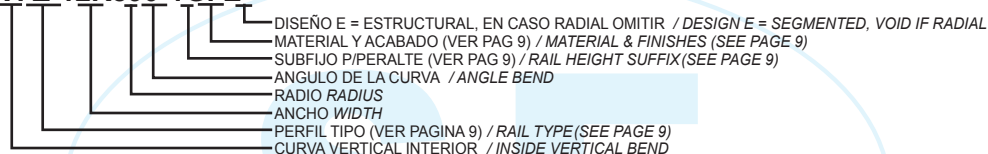

NUMEROS DE CATALOGO PARA CURVA A 90° 90° BEND CATALOG NUMBER

ANCHO W WIDTH W	RADIO RADIUS			
	203.2 (8)	304.8 (12)	609.6 (24)	914.4 (36)
101.6 (4)	VI-04R890	VI-04R1290	VI-04R2490	VI-04R3690
152.4 (6)	VI-06R890	VI-06R1290	VI-06R2490	VI-06R3690
228.9 (9)	VI-09R890	VI-09R1290	VI-09R2490	VI-09R3690
304.8 (12)	VI-12R890	VI-12R1290	VI-12R2490	VI-12R3690
406.4 (16)	VI-16R890	VI-16R1290	VI-16R2490	VI-16R3690
457.2 (18)	VI-18R890	VI-18R1290	VI-18R2490	VI-18R3690
508.0 (20)	VI-20R890	VI-20R1290	VI-20R2490	VI-20R3690
609.6 (24)	VI-24R890	VI-24R1290	VI-24R2490	VI-24R3690
762.0 (30)	VI-30R890	VI-30R1290	VI-30R2490	VI-30R3690
914.4 (36)	VI-36R890	VI-36R1290	VI-36R2490	VI-36R3690

NUMEROS DE CATALOGO PARA CURVA A 45° 45° BEND CATALOG NUMBER

ANCHO W WIDTH W	RADIO RADIUS			
	203.2 (8)	304.8 (12)	609.6 (24)	914.4 (36)
101.6 (4)	VI-04R845	VI-04R1245	VI-04R2445	VI-04R3645
152.4 (6)	VI-06R845	VI-06R1245	VI-06R2445	VI-06R3645
228.9 (9)	VI-09R845	VI-09R1245	VI-09R2445	VI-09R3645
304.8 (12)	VI-12R845	VI-12R1245	VI-12R2445	VI-12R3645
406.4 (16)	VI-16R845	VI-16R1245	VI-16R2445	VI-16R3645
457.2 (18)	VI-18R845	VI-18R1245	VI-18R2445	VI-18R3645
508.0 (20)	VI-20R845	VI-20R1245	VI-20R2445	VI-20R3645
609.6 (24)	VI-24R845	VI-24R1245	VI-24R2445	VI-24R3645
762.0 (30)	VI-30R845	VI-30R1245	VI-30R2445	VI-30R3645
914.4 (36)	VI-36R845	VI-36R1245	VI-36R2445	VI-36R3645

INCLUYE 2 CONECTORES Y TORNILLERIA / TWO CONNECTORS AND HARDWARE INCLUDED

TODAS LAS DIMENSIONES EN mm (Pulg) / ALL DIMENSIONS ARE IN mm (Inch)

PUEDEN SER SUJETOS A MODIFICACION SIN PREVIO AVISO / MAY BE SUBJECT TO MODIFICATION WITHOUT NOTICE



"T" HORIZONTAL

DISEÑO RADIAL PARA PERFIL Z
RADIAL DESIGN FOR RAIL TYPE Z

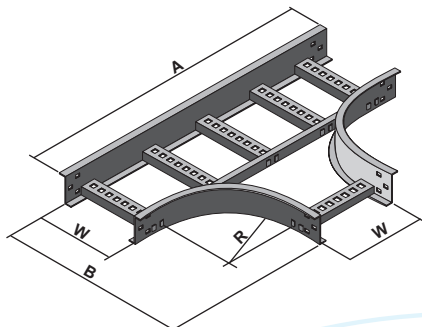

HORIZONTAL TEE

DISEÑO ESTRUCTURAL PARA PERFIL "Z", "C" E "I"
SEGMENTED DESIGN FOR RAIL TYPE "Z", "C" & "I"

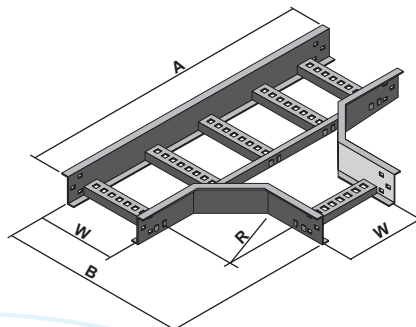

TH Z-12 R8-1GI E

- DISEÑO E = ESTRUCTURAL, EN CASO RADIAL OMITIR / DESIGN E = SEGMENTED, VOID IF RADIAL
- MATERIAL Y ACABADO (VER PAG 9) / MATERIAL & FINISHES (SEE PAGE 9)
- SUBFIJO P/PERALTE (VER PAG 9) / RAIL HEIGHT SUFFIX (SEE PAGE 9)
- RADIO RADIUS
- ANCHO WIDTH
- PERFIL TIPO (VER PAGINA 9) / RAIL TYPE (SEE PAGE 9)
- "T" HORIZONTAL HORIZONTAL "T"

ANCHO W WIDTH W	RADIO 203.2 RADIUS (8) SOLO RADIAL RADIAL ONLY			RADIO 304.8 RADIUS (12)		
	No DE CATALOGO CATALOG NUMBER	A	B	No DE CATALOGO CATALOG NUMBER	A	B
101.6 (4)	TH-04R8	731 (28.78)	416 (16.39)	TH-04R12	864 (34)	518 (20.39)
152.4 (6)	TH-06R8	782 (30.78)	467 (18.39)	TH-06R12	914 (36)	569 (22.39)
228.9 (9)	TH-09R8	585 (23.03)	543 (21.39)	TH-09R12	991 (39)	645 (25.39)
304.8 (12)	TH-12R8	934 (36.78)	619 (24.39)	TH-12R12	1137 (44.78)	721 (28.39)
406.4 (16)	TH-16R8	1036 (40.78)	721 (28.39)	TH-16R12	1239 (48.78)	823 (32.39)
457.2 (18)	TH-18R8	1086 (42.78)	772 (30.39)	TH-18R12	1290 (50.78)	873 (34.39)
508.0 (20)	TH-20R8	1137 (44.78)	823 (32.39)	TH-20R12	1341 (52.78)	924 (36.39)
609.6 (24)	TH-24R8	1239 (48.78)	924 (36.39)	TH-24R12	1442 (56.78)	1026 (40.39)
762.0 (30)	TH-30R8	1391 (54.78)	1077 (42.39)	TH-30R12	1595 (62.78)	1178 (46.39)
914.4 (36)	TH-36R8	1543 (60.78)	1229 (48.39)	TH-36R12	1747 (68.78)	1331 (52.39)

ANCHO W WIDTH W	RADIO 609.6 RADIUS (24)			RADIO 914.4 RADIUS (36)		
	No DE CATALOGO CATALOG NUMBER	A	B	No DE CATALOGO CATALOG NUMBER	A	B
101.6 (4)	TH-04R24	1544 (60.78)	823 (32.39)	TH-04R36	2153 (84.78)	1127 (44.39)
152.4 (6)	TH-06R24	1595 (62.78)	873 (34.39)	TH-06R36	2204 (86.78)	1178 (46.39)
228.9 (9)	TH-09R24	1671 (65.78)	950 (37.39)	TH-09R36	2280 (89.78)	1254 (49.39)
304.8 (12)	TH-12R24	1747 (68.78)	1030 (40.39)	TH-12R36	2357 (92.78)	1331 (52.39)
406.4 (16)	TH-16R24	1849 (72.78)	1127 (44.39)	TH-16R36	2458 (96.78)	1432 (56.39)
457.2 (18)	TH-18R24	1899 (74.78)	1178 (46.39)	TH-18R36	2509 (98.78)	1483 (58.39)
508.0 (20)	TH-20R24	1950 (76.78)	1229 (48.39)	TH-20R36	2560 (100.78)	1534 (60.39)
609.6 (24)	TH-24R24	2052 (80.78)	1331 (52.39)	TH-24R36	2661 (104.78)	1635 (64.39)
762.0 (30)	TH-30R24	2204 (86.78)	1483 (58.39)	TH-30R36	2814 (110.78)	1788 (70.39)
914.4 (36)	TH-36R24	2357 (92.78)	1635 (64.39)	TH-36R36	2966 (116.78)	1940 (76.39)

INCLUYE 2 CONECTORES Y TORNILLERIA / TWO CONNECTORS AND HARDWARE INCLUDED

TODAS LAS DIMENSIONES EN mm (Pulg) / ALL DIMENSIONS ARE IN mm (Inch)

PUEDEN SER SUJETOS A MODIFICACION SIN PREVIO AVISO / MAY BE SUBJECT TO MODIFICATION WITHOUT NOTICE

"X" HORIZONTAL

DISEÑO RADIAL PARA PERFIL Z
RADIAL DESIGN FOR RAIL TYPE Z

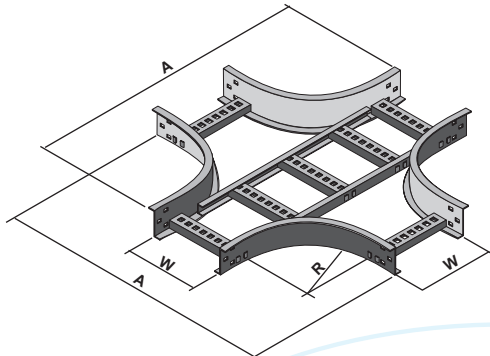

HORIZONTAL CROSS

DISEÑO ESTRUCTURAL PARA PERFIL "Z", "C" E "I"
SEGMENTED DESIGN FOR RAIL TYPE "Z", "C" & "I"

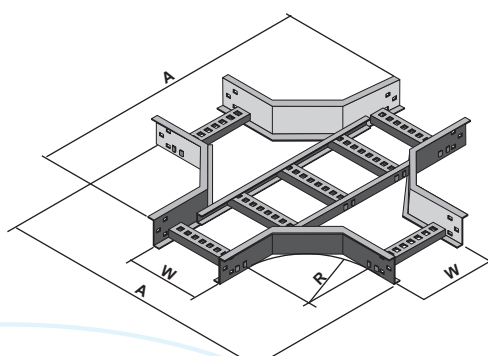

XH Z - 12R8-1GI E

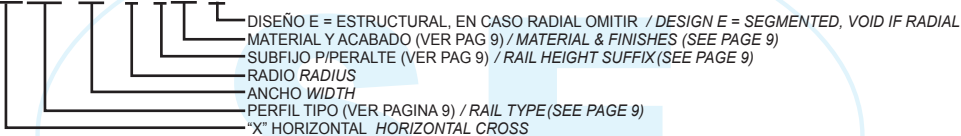

ANCHO W WIDTH W	RADIO 203.2 RADIUS (8)		RADIO 304.8 RADIUS (12)	
	No DE CATALOGO CATALOG NUMBER	A	No DE CATALOGO CATALOG NUMBER	A
101.6 (4)	XH-04R8	731 (28.78)	XH-04R12	864 (34)
152.4 (6)	XH-06R8	782 (30.78)	XH-06R12	914 (36)
228.9 (9)	XH-09R8	585 (23.03)	XH-09R12	991 (39)
304.8 (12)	XH-12R8	934 (36.78)	XH-12R12	1137 (44.78)
406.4 (16)	XH-16R8	1036 (40.78)	XH-16R12	1239 (48.78)
457.2 (18)	XH-18R8	1086 (42.78)	XH-18R12	1290 (50.78)
508.0 (20)	XH-20R8	1137 (44.78)	XH-20R12	1341 (52.78)
609.6 (24)	XH-24R8	1239 (48.78)	XH-24R12	1442 (56.78)
762.0 (30)	XH-30R8	1391 (54.78)	XH-30R12	1595 (62.78)
914.4 (36)	XH-36R8	1543 (60.78)	XH-36R12	1747 (68.78)

ANCHO W WIDTH W	RADIO 609.6 RADIUS (24)		RADIO 914.4 RADIUS (36)	
	No DE CATALOGO CATALOG NUMBER	A	No DE CATALOGO CATALOG NUMBER	A
101.6 (4)	XH-04R24	1544 (60.78)	XH-04R36	2153 (84.78)
152.4 (6)	XH-06R24	1595 (62.78)	XH-06R36	2204 (86.78)
228.9 (9)	XH-09R24	1671 (65.78)	XH-09R36	2280 (89.78)
304.8 (12)	XH-12R24	1747 (68.78)	XH-12R36	2357 (92.78)
406.4 (16)	XH-16R24	1849 (72.78)	XH-16R36	2458 (96.78)
457.2 (18)	XH-18R24	1899 (74.78)	XH-18R36	2509 (98.78)
508.0 (20)	XH-20R24	1950 (76.78)	XH-20R36	2560 (100.78)
609.6 (24)	XH-24R24	2052 (80.78)	XH-24R36	2661 (104.78)
762.0 (30)	XH-30R24	2204 (86.78)	XH-30R36	2814 (110.78)
914.4 (36)	XH-36R24	2357 (92.78)	XH-36R36	2966 (116.78)

INCLUYE 2 CONECTORES Y TORNILLERIA / TWO CONNECTORS AND HARDWARE INCLUDED

TODAS LAS DIMENSIONES EN mm (Pulg) / ALL DIMENSIONS ARE IN mm (Inch)

PUEDEN SER SUJETOS A MODIFICACION SIN PREVIO AVISO / MAY BE SUBJECT TO MODIFICATION WITHOUT NOTICE

PRODUCTOS SOPORTES ELECTRICOS

T VERTICAL

DISEÑO RADIAL PARA PERFIL Z,
RADIOS 203.2 Y 304.8 (8 Y 12)
RADIAL DESIGN FOR RAIL TYPE Z,
RADIUS 203.2 & 304.8 (8 & 12)

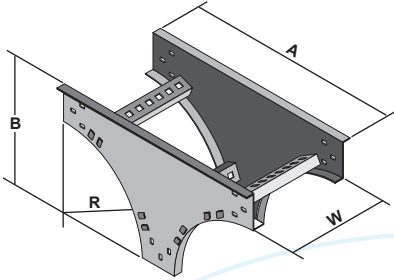

VERTICAL TEE

DISEÑO ESTRUCTURAL PARA PERFIL "Z" "C" E "I"
RADIOS 304.8, 609.6 Y 914.4 (12, 24 Y 36)
SEGMENTED DESIGN FOR RAIL TYPE "Z" "C" & "I"
RADIUS 304.8, 609.6 & 914.4 (12, 24 & 36)

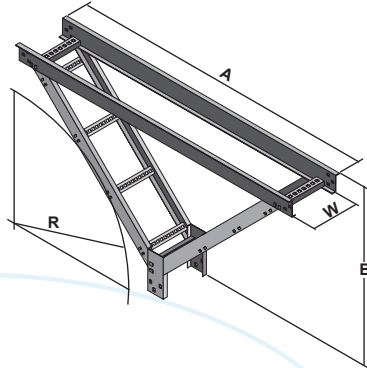

TV Z-12R8-1GI E

- DISEÑO E = ESTRUCTURAL, EN CASO RADIAL OMITIR / DESIGN E = SEGMENTED, VOID IF RADIAL
- MATERIAL Y ACABADO (VER PAG 9) / MATERIAL & FINISHES (SEE PAGE 9)
- SUBFIJO P/PERALTE (VER PAG 9) / RAIL HEIGHT SUFFIX (SEE PAGE 9)
- RADIO RADIUS
- ANCHO WIDTH
- PERFIL TIPO (VER PAGINA 9) / RAIL TYPE (SEE PAGE 9)
- "T" VERTICAL VERTICAL "T"

NUMEROS DE CATALOGO CATALOG NUMBER

ANCHO W WIDTH W	RADIO RADIUS			
	203.2 (8)	304.8 (12)	609.6 (24)	914.4 (36)
101.6 (4)	TV-04R8	TV-04R12	TV-04R24	TV-04R36
152.4 (6)	TV-06R8	TV-06R12	TV-06R24	TV-06R36
228.9 (9)	TV-09R8	TV-09R12	TV-09R24	TV-09R36
304.8 (12)	TV-12R8	TV-12R12	TV-12R24	TV-12R36
406.4 (16)	TV-16R8	TV-16R12	TV-16R24	TV-16R36
457.2 (18)	TV-18R8	TV-18R12	TV-18R24	TV-18R36
508.0 (20)	TV-20R8	TV-20R12	TV-20R24	TV-20R36
609.6 (24)	TV-24R8	TV-24R12	TV-24R24	TV-24R36
762.0 (30)	TV-30R8	TV-30R12	TV-30R24	TV-30R36
914.4 (36)	TV-36R8	TV-36R12	TV-36R24	TV-36R36

SUBFIJO P/PERALTE HEIGHT RAIL SUFFIX	RADIO RADIUS							
	203.2 (8)		304.8 (12)		609.6 (24)		914.4 (36)	
	A	B	A	B	A	B	A	B
1	489 (19.25)	286 (11.25)	692 (27.25)	387 (15.25)	1302 (51.25)	692 (27.25)	1911 (75.25)	997 (39.25)
2	508 (20)	305 (12)	711 (28)	406 (16)	1321 (52)	711 (28)	1930 (76)	1016 (40)
3	521 (20.5)	318 (12.5)	724 (28.5)	419 (16.5)	1334 (52.5)	724 (28.5)	1943 (76.5)	1029 (40.5)
5	533 (21)	330 (13)	737 (29)	432 (17)	1346 (53)	737 (29)	1956 (77)	1041 (41)
6	559 (22)	356 (14)	762 (30)	457 (18)	1372 (54)	762 (30)	1981 (78)	1067 (42)

INCLUYE 2 CONECTORES Y TORNILLERIA / TWO CONNECTORS AND HARDWARE INCLUDED

TODAS LAS DIMENSIONES EN mm (Pulg) / ALL DIMENSIONS ARE IN mm (Inch)

PUEDEN SER SUJETOS A MODIFICACION SIN PREVIO AVISO / MAY BE SUBJECT TO MODIFICATION WITHOUT NOTICE

"X" VERTICAL

DISEÑO RADIAL PARA PERFIL Z Y C,
RADIOS 203.2 Y 304.8 (8 Y 12)
RADIAL DESIGN FOR RAIL TYPE Z Y C,
RADIUS 203.2 & 304.8 (8 & 12)

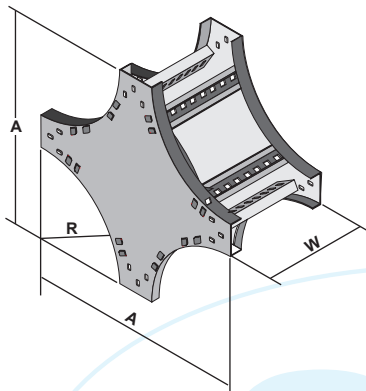

VERTICAL CROSS

DISEÑO ESTRUCTURAL PARA PERFIL "Z" "C" E "I"
RADIOS 304.8, 609.6 Y 914.4 (12, 24 Y 36)
SEGMENTED DESIGN FOR RAIL TYPE "Z" "C" & "I"
RADIUS 304.8, 609.6 & 914.4 (12, 24 & 36)

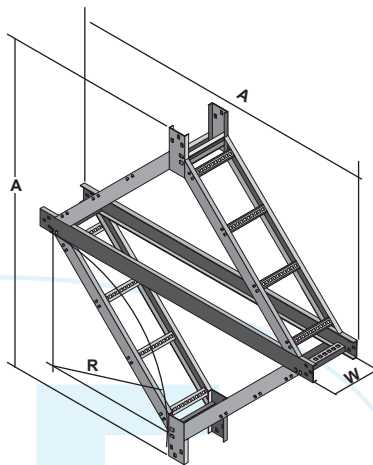

XV Z-12R8-1GI E



DISEÑO E = ESTRUCTURAL, EN CASO RADIAL OMITIR / DESIGN E = SEGMENTED, VOID IF RADIAL
MATERIAL Y ACABADO (VER PAG 9) / MATERIAL & FINISHES (SEE PAGE 9)
SUBFIJO P/PERALTE (VER PAG 9) / RAIL HEIGHT SUFFIX (SEE PAGE 9)
RADIO RADIUS
ANCHO WIDTH
PERFIL TIPO (VER PAGINA 9) / RAIL TYPE (SEE PAGE 9)
"X" VERTICAL VERTICAL CROSS

NUMEROS DE CATALOGO CATALOG NUMBER

ANCHO W WIDTH W	RADIO RADIUS			
	203.2 (8)	304.8 (12)	609.6 (24)	914.4 (36)
101.6 (4)	XV-04R8	XV-04R12	XV-04R24	XV-04R36
152.4 (6)	XV-06R8	XV-06R12	XV-06R24	XV-06R36
228.9 (9)	XV-09R8	XV-09R12	XV-09R24	XV-09R36
304.8 (12)	XV-12R8	XV-12R12	XV-12R24	XV-12R36
406.4 (16)	XV-16R8	XV-16R12	XV-16R24	XV-16R36
457.2 (18)	XV-18R8	XV-18R12	XV-18R24	XV-18R36
508.0 (20)	XV-20R8	XV-20R12	XV-20R24	XV-20R36
609.6 (24)	XV-24R8	XV-24R12	XV-24R24	XV-24R36
762.0 (30)	XV-30R8	XV-30R12	XV-30R24	XV-30R36
914.4 (36)	XV-36R8	XV-36R12	XV-36R24	XV-36R36

DIMENSION A A DIMENSION

SUBFIJO P/PERALTE HEIGHT RAIL SUFFIX	RADIO RADIUS			
	203.2 (8)	304.8 (12)	609.6 (24)	914.4 (36)
1	489 (19.25)	692 (27.25)	1302 (51.25)	1911 (75.25)
2	508 (20)	711 (28)	1321 (52)	1930 (76)
3	521 (20.5)	724 (28.5)	1334 (52.5)	1943 (76.5)
5	533 (21)	737 (29)	1346 (53)	1956 (77)
6	559 (22)	762 (30)	1372 (54)	1981 (78)

INCLUYE 2 CONECTORES Y TORNILLERIA / TWO CONNECTORS AND HARDWARE INCLUDED

TODAS LAS DIMENSIONES EN mm (Pulg) / ALL DIMENSIONS ARE IN mm (Inch)

PUEDEN SER SUJETOS A MODIFICACION SIN PREVIO AVISO / MAY BE SUBJECT TO MODIFICATION WITHOUT NOTICE



CURVA HORIZONTAL AJUSTABLE

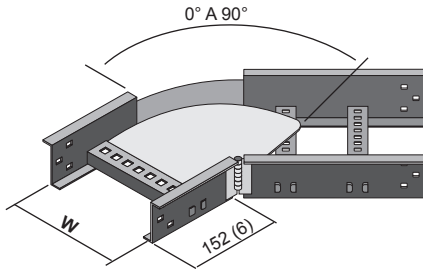

HORIZONTAL ADJUSTABLE BEND

ANCHO W WIDTH W	N° DE CATALOGO CATALOG NUMBER
101.6 (4)	CA-04
152.4 (6)	CA-06
228.9 (9)	CA-09
304.8 (12)	CA-12
406.4 (16)	CA-16
457.2 (18)	CA-18
508.0 (20)	CA-20
609.6 (24)	CA-24
762.0 (30)	CA-30
914.4 (36)	CA-36

INCLUYE 2 CONECTORES Y TORNILLERIA
TWO CONNECTORS AND HARDWARE INCLUDED

NO INCLUYE CINTAS CONDUCTORAS
BONDING JUMPERS NOT INCLUDED

CA Z-12-1GI

- MATERIAL Y ACABADO (VER PAG 9) MATERIAL & FINISHES (SEE PAGE 9)
- SUBFIJO P/PERALTE (VER PAG 9) RAIL HEIGHT SUFFIX (SEE PAGE 9)
- ANCHO WIDTH
- PERFIL TIPO (VER PAGINA 9) RAIL TYPE (SEE PAGE 9)
- CURVA HORIZONTAL AJUSTABLE HORIZONTAL ADJUSTABLE BEND
- DERECHA O IZQUIERDA RIGHT OR LEFT

DERIVACION HORIZONTAL A 45° DERECHA O IZQUIERDA

45° HORIZONTAL JUNCTION RIGHT OR LEFT

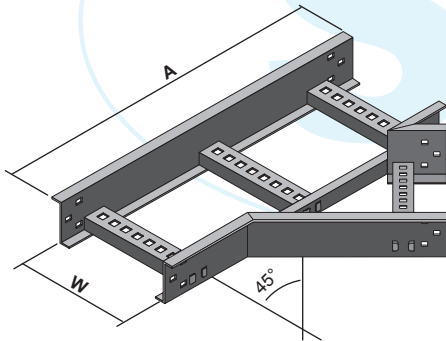

ANCHO W WIDTH W	N° DE CATALOGO CATALOG NUMBER	A
101.6 (4)	DYD-04	463 (18.2)
152.4 (6)	DYD-06	534 (21)
228.9 (9)	DYD-09	642 (25.3)
304.8 (12)	DYD-12	750 (29.5)
406.4 (16)	DYD-16	894 (35.2)
457.2 (18)	DYD-18	966 (38)
508.0 (20)	DYD-20	1037 (40.8)
609.6 (24)	DYD-24	1181 (46.5)
762.0 (30)	DYD-30	1396 (55)
914.4 (36)	DYD-36	1612 (63.5)

INCLUYE 2 CONECTORES Y TORNILLERIA
TWO CONNECTORS AND HARDWARE INCLUDED

DY DZ-12-1GI

- MATERIAL Y ACABADO (VER PAG 9) MATERIAL & FINISHES (SEE PAGE 9)
- SUBFIJO P/PERALTE (VER PAG 9) RAIL HEIGHT SUFFIX (SEE PAGE 9)
- ANCHO WIDTH
- PERFIL TIPO (VER PAGINA 9) RAIL TYPE (SEE PAGE 9)
- DERIVACION HORIZONTAL A 45° 45° HORIZONTAL JUNCTION
(D Y D PARA DERECHA D AND D TO RIGHT)
(D Y I PARA IZQUIERDA D AND I TO LEFT)

TODAS LAS DIMENSIONES EN mm (Pulg) / ALL DIMENSIONS ARE IN mm (Inch)
PUEDEN SER SUJETOS A MODIFICACION SIN PREVIO AVISO / MAY BE SUBJECT TO MODIFICATION WITHOUT NOTICE

REDUCCIONES

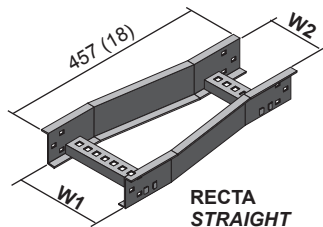

**RECTA
STRAIGHT**

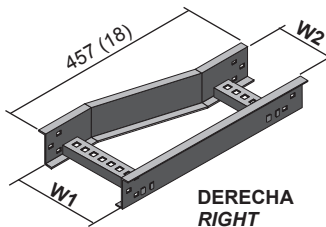

**DERECHA
RIGHT**

REDUCERS

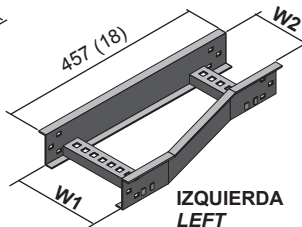

**IZQUIERDA
LEFT**

RL Z -12 09-1GI

- MATERIAL Y ACABADO (VER PAG 9) MATERIAL & FINISHES (SEE PAGE 9)
- SUBFIJO P/PERALTE (VER PAG 9) RAIL HEIGHT SUFFIX (SEE PAGE 9)
- ANCHO MENOR SMALLER WIDTH
- ANCHO MAYOR LARGER WIDTH
- PERFIL TIPO (VER PAGINA 9) RAIL TYPE (SEE PAGE 9)
- REDUCCION REDUCER
- RL = RECTA STRAIGHT
- RLD = DERECHA RIGHT
- RLI = IZQUIERDA LEFT

N° DE CATALOGO REDUCCIONES RECTAS / STRAIGHT REDUCER CATALOG NUMBER

ANCHO W1 WIDTH W1	ANCHO MENOR W2 SMALLER WIDTH W2								
	101.6 (4)	152.4 (6)	228.9 (9)	304.8 (12)	406.4 (16)	457.2 (18)	508.0 (20)	609.6 (24)	762.0 (36)
152.4 (6)	RL-0604								
228.9 (9)	RL-0904	RL-0906							
304.8 (12)	RL-1204	RL-1206	RL-1209						
406.4 (16)	RL-1604	RL-1606	RL-1609	RL-1612					
457.2 (18)	RL-1804	RL-1806	RL-1809	RL-1812	RL-1816				
508.0 (20)	RL-2004	RL-2006	RL-2009	RL-2012	RL-2016	RL-2018			
609.6 (24)	RL-2404	RL-2406	RL-2409	RL-2412	RL-2416	RL-2418	RL-2420		
762.0 (30)	RL-3004	RL-3006	RL-3009	RL-3012	RL-3016	RL-3018	RL-3020	RL-3024	
914.4 (36)	RL-3604	RL-3606	RL-3609	RL-3612	RL-3616	RL-3618	RL-3620	RL-3624	RL-3630

N° DE CATALOGO REDUCCIONES DERECHAS / RIGHT REDUCER CATALOG NUMBER

ANCHO W1 WIDTH W1	ANCHO MENOR W2 SMALLER WIDTH W2								
	101.6 (4)	152.4 (6)	228.9 (9)	304.8 (12)	406.4 (16)	457.2 (18)	508.0 (20)	609.6 (24)	762.0 (36)
152.4 (6)	RLD-0604								
228.9 (9)	RLD-0904	RLD-0906							
304.8 (12)	RLD-1204	RLD-1206	RLD-1209						
406.4 (16)	RLD-1604	RLD-1606	RLD-1609	RLD-1612					
457.2 (18)	RLD-1804	RLD-1806	RLD-1809	RLD-1812	RLD-1816				
508.0 (20)	RLD-2004	RLD-2006	RLD-2009	RLD-2012	RLD-2016	RLD-2018			
609.6 (24)	RLD-2404	RLD-2406	RLD-2409	RLD-2412	RLD-2416	RLD-2418	RLD-2420		
762.0 (30)	RLD-3004	RLD-3006	RLD-3009	RLD-3012	RLD-3016	RLD-3018	RLD-3020	RLD-3024	
914.4 (36)	RLD-3604	RLD-3606	RLD-3609	RLD-3612	RLD-3616	RLD-3618	RLD-3620	RLD-3624	RLD-3630

N° DE CATALOGO REDUCCIONES IZQUIERDAS / LEFT REDUCER CATALOG NUMBER

ANCHO W1 WIDTH W1	ANCHO MENOR W2 SMALLER WIDTH W2								
	101.6 (4)	152.4 (6)	228.9 (9)	304.8 (12)	406.4 (16)	457.2 (18)	508.0 (20)	609.6 (24)	762.0 (36)
152.4 (6)	RLI-0604								
228.9 (9)	RLI-0904	RLI-0906							
304.8 (12)	RLI-1204	RLI-1206	RLI-1209						
406.4 (16)	RLI-1604	RLI-1606	RLI-1609	RLI-1612					
457.2 (18)	RLI-1804	RLI-1806	RLI-1809	RLI-1812	RLI-1816				
508.0 (20)	RLI-2004	RLI-2006	RLI-2009	RLI-2012	RLI-2016	RLI-2018			
609.6 (24)	RLI-2404	RLI-2406	RLI-2409	RLI-2412	RLI-2416	RLI-2418	RLI-2420		
762.0 (30)	RLI-3004	RLI-3006	RLI-3009	RLI-3012	RLI-3016	RLI-3018	RLI-3020	RLI-3024	
914.4 (36)	RLI-3604	RLI-3606	RLI-3609	RLI-3612	RLI-3616	RLI-3618	RLI-3620	RLI-3624	RLI-3630

INCLUYE 2 CONECTORES Y TORNILLERIA / TWO CONNECTORS AND HARDWARE INCLUDED

TODAS LAS DIMENSIONES EN mm (Pulg) / ALL DIMENSIONS ARE IN mm (Inch)

PUEDEN SER SUJETOS A MODIFICACION SIN PREVIO AVISO / MAY BE SUBJECT TO MODIFICATION WITHOUT NOTICE

SECCION 1.2 SOPORTERIA PARA CABLES TIPO FONDO SOLIDO Y FONDO VENTILADO

SECTION 1.2 CABLE TRAY SYSTEM SOLID AND VENTILATED BOTTOM TYPE

SECCIONES TIPO "Z"

FORM "Z" SECTIONS

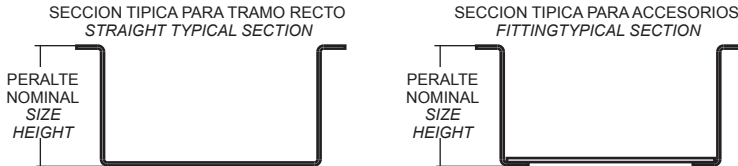

PERALTE NOMINAL SIZE HEIGHT	TIPO DE FONDO BOTTOM TYPE		SUBFIJO P/PERALTE RAIL HEIGHT SUFFIX
	LISO SOLID	VENTILADO VENTILATED	
82.5 (3.25)	ZL	ZP	1
101.6 (4)	ZL	ZP	2
114.3 (4.5)	ZL	ZP	3
127.0 (5)	ZL	ZP	5
152.4 (6)	ZL	ZP	6

SECCIONES TIPO "C"

FORM "C" SECTIONS

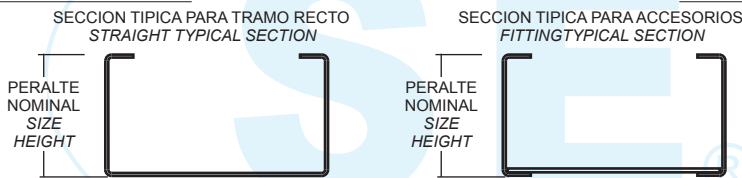

PERALTE NOMINAL SIZE HEIGHT	TIPO DE FONDO BOTTOM TYPE		SUBFIJO P/PERALTE RAIL HEIGHT SUFFIX
	LISO SOLID	VENTILADO VENTILATED	
82.5 (3.25)	CL	CP	1
101.6 (4)	CL	CP	2
114.3 (4.5)	CL	CP	3
127.0 (5)	CL	CP	5
152.4 (6)	CL	CP	6

PARA ANCHOS DE 36" EN PERALTE DE 6" SUJETO A CAMBIO DE DISEÑO
WIDE FOR 36" IN RISER 6" DESIGN IS SUBJECT TO CHANGE

MATERIALES Y ACABADOS DISPONIBLES:
A: ALUMINIO ALEACION AA-6063 ACABADO NATURAL

MATERIALS & FINISHES AVAILABLE:
A: AA-6063 NATURAL FINISHED ALUMINUM

GI: ACERO AL CARBONO GALVANIZADO POR INMERSION EN CALIENTE SEGUN ASTM A 525

GI: HOT DIP GALVANIZED STEEL UNDER ASTM A 525

GE: ACERO AL CARBONO GALVANIZADO ELECTROLITICO SEGUN ASTM B 633

GE: ELECTROGALVANIZED STEEL UNDER ASTM B 633

T: ACERO AL CARBONO TROPICALIZADO

T: CHROMIUM-ZINC COATED STEEL

AI: ACERO INOXIDABLE ACABADO NATURAL

AI: NATURAL FINISHED STAINLESS STEEL

PARA MATERIALES Y ACABADOS NO INDICADOS CONSULTE NUESTRO DEPARTAMENTO DE INGENIERIA
FOR MATERIALS AND FINISHES NOT SHOWN, PLEASE CONSULT OUR TECHNICAL DEPARTMENT

TODAS LAS DIMENSIONES EN mm (Pulg) / ALL DIMENSIONS ARE IN mm (Inch)

PUEDEN SER SUJETOS A MODIFICACION SIN PREVIO AVISO / MAY BE SUBJECT TO MODIFICATION WITHOUT NOTICE

TRAMO RECTO

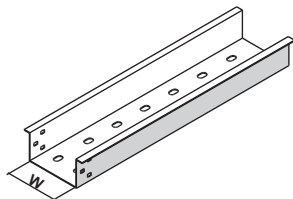

CHZL-12-1GI



MATERIAL Y ACABADO (VER PAG 20) MATERIAL & FINISHES (SEE PAGE 20)
 SUBFIJO P/PERALTE (VER PAG 20) RAIL HEIGHT SUFFIX (SEE PAGE 20)
 ANCHO WIDTH
 TIPO DE FONDO (VER PAGINA 20) BOTTOM TYPE (SEE PAGE 20)
 TRAMO RECTO STRAIGHT SECTION

STRAIGHT SECTION

LONGITUD ESTANDARD 3.048 m (10 PIES)
 STANDARD LENGHT 3.048 m (10 ft)

PARA LONGITUDES DIFERENTES CONSULTE
 NUESTRO DEPARTAMENTO DE INGENIERIA
 FOR OTHER LENGHT PLEASE CONSULT
 OUR TECHNICAL DEPARTMENT

INCLUYE 2 CONECTORES Y TORNILLERIA
 TWO CONNECTOR AND HARDWARE INCLUDED

ANCHO W WIDTH W	PERFIL TIPO Z FORM Z		PERFIL TIPO C C FORM	
	LISO SOLID	VENTILADO VENTILATED	LISO SOLID	VENTILADO VENTILATED
101.6 (4)	CHZL-04	CHZP-04	CHCL-04	CHCP-04
152.4 (6)	CHZL-06	CHZP-06	CHCL-06	CHCP-06
228.9 (9)	CHZL-09	CHZP-09	CHCL-09	CHCP-09
304.8 (12)	CHZL-12	CHZP-12	CHCL-12	CHCP-12
406.4 (16)	CHZL-16	CHZP-16	CHCL-16	CHCP-16
457.2 (18)	CHZL-18	CHZP-18	CHCL-18	CHCP-18
508.0 (20)	CHZL-20	CHZP-20	CHCL-20	CHCP-20
609.6 (24)	CHZL-24	CHZP-24	CHCL-24	CHCP-24
762.0 (30)	CHZL-30	CHZP-30	CHCL-30	CHCP-30
914.4 (36)	CHZL-36	CHZP-36	CHCL-36	CHCP-36

CURVA HORIZONTAL A 45° Y 90°

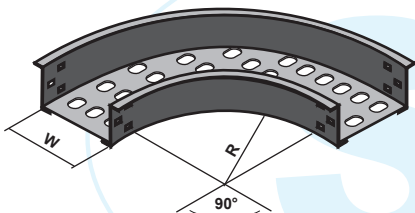

VH ZP-12R890-1GI

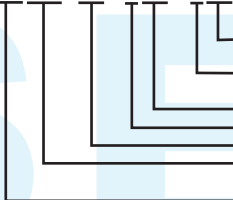

MATERIAL Y ACABADO (VER PAG 20) MATERIAL & FINISHES (SEE PAGE 20)
 SUBFIJO P/PERALTE (VER PAG 20) RAIL HEIGHT SUFFIX (SEE PAGE 20)
 ANGULO DE LA CURVA ANGLE BEND
 RADIO RADIUS
 ANCHO WIDTH
 TIPO DE FONDO (VER PAGINA 20) BOTTOM TYPE (SEE PAGE 20)
 CURVA HORIZONTAL HORIZONTAL BEND

45° & 90° HORIZONTAL BEND

NUMEROS DE CATALOGO PARA CURVA A 90° 90° BEND CATALOG NUMBER

ANCHO W WIDTH W	RADIO RADIUS			
	203.2 (8)	304.8 (12)	609.6 (24)	914.4 (36)
101.6 (4)	VH-04R890	VH-04R1290	VH-04R2490	VH-04R3690
152.4 (6)	VH-06R890	VH-06R1290	VH-06R2490	VH-06R3690
228.9 (9)	VH-09R890	VH-09R1290	VH-09R2490	VH-09R3690
304.8 (12)	VH-12R890	VH-12R1290	VH-12R2490	VH-12R3690
406.4 (16)	VH-16R890	VH-16R1290	VH-16R2490	VH-16R3690
457.2 (18)	VH-18R890	VH-18R1290	VH-18R2490	VH-18R3690
508.0 (20)	VH-20R890	VH-20R1290	VH-20R2490	VH-20R3690
609.6 (24)	VH-24R890	VH-24R1290	VH-24R2490	VH-24R3690
762.0 (30)	VH-30R890	VH-30R1290	VH-30R2490	VH-30R3690
914.4 (36)	VH-36R890	VH-36R1290	VH-36R2490	VH-36R3690

NUMEROS DE CATALOGO PARA CURVA A 45° 45° BEND CATALOG NUMBER

ANCHO W WIDTH W	RADIO RADIUS			
	203.2 (8)	304.8 (12)	609.6 (24)	914.4 (36)
101.6 (4)	VH-04R845	VH-04R1245	VH-04R2445	VH-04R3645
152.4 (6)	VH-06R845	VH-06R1245	VH-06R2445	VH-06R3645
228.9 (9)	VH-09R845	VH-09R1245	VH-09R2445	VH-09R3645
304.8 (12)	VH-12R845	VH-12R1245	VH-12R2445	VH-12R3645
406.4 (16)	VH-16R845	VH-16R1245	VH-16R2445	VH-16R3645
457.2 (18)	VH-18R845	VH-18R1245	VH-18R2445	VH-18R3645
508.0 (20)	VH-20R845	VH-20R1245	VH-20R2445	VH-20R3645
609.6 (24)	VH-24R845	VH-24R1245	VH-24R2445	VH-24R3645
762.0 (30)	VH-30R845	VH-30R1245	VH-30R2445	VH-30R3645
914.4 (36)	VH-36R845	VH-36R1245	VH-36R2445	VH-36R3645

INCLUYE 2 CONECTORES Y TORNILLERIA / TWO CONNECTOR AND HARDWARE INCLUDED

TODAS LAS DIMENSIONES EN mm (Pulg) / ALL DIMENSIONS ARE IN mm (Inch)

PUEDEN SER SUJETOS A MODIFICACION SIN PREVIO AVISO / MAY BE SUBJECT TO MODIFICATION WITHOUT NOTICE

CURVA VERTICAL EXTERIOR A 45° Y 90°

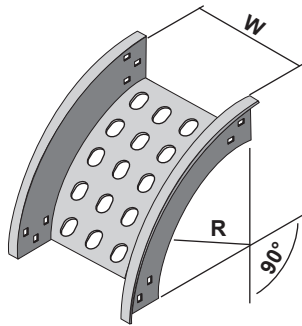

45° & 90° OUTSIDE VERTICAL BEND

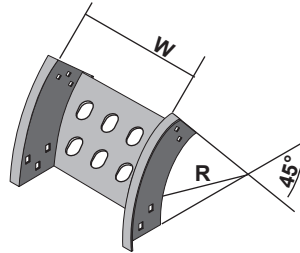

VEZP-12R890-1GI

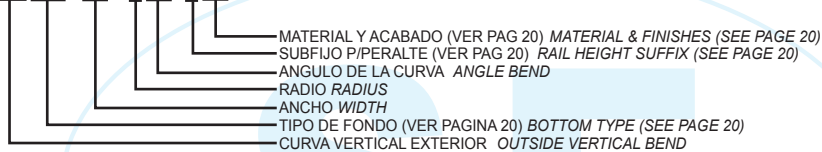

NUMEROS DE CATALOGO PARA CURVA A 90° 90° BEND CATALOG NUMBER

ANCHO W WIDTH W	RADIO RADIUS			
	203.2 (8)	304.8 (12)	609.6 (24)	914.4 (36)
101.6 (4)	VE-04R890	VE-04R1290	VE-04R2490	VE-04R3690
152.4 (6)	VE-06R890	VE-06R1290	VE-06R2490	VE-06R3690
228.9 (9)	VE-09R890	VE-09R1290	VE-09R2490	VE-09R3690
304.8 (12)	VE-12R890	VE-12R1290	VE-12R2490	VE-12R3690
406.4 (16)	VE-16R890	VE-16R1290	VE-16R2490	VE-16R3690
457.2 (18)	VE-18R890	VE-18R1290	VE-18R2490	VE-18R3690
508.0 (20)	VE-20R890	VE-20R1290	VE-20R2490	VE-20R3690
609.6 (24)	VE-24R890	VE-24R1290	VE-24R2490	VE-24R3690
762.0 (30)	VE-30R890	VE-30R1290	VE-30R2490	VE-30R3690
914.4 (36)	VE-36R890	VE-36R1290	VE-36R2490	VE-36R3690

NUMEROS DE CATALOGO PARA CURVA A 45° 45° BEND CATALOG NUMBER

ANCHO W WIDTH W	RADIO RADIUS			
	203.2 (8)	304.8 (12)	609.6 (24)	914.4 (36)
101.6 (4)	VE-04R845	VE-04R1245	VE-04R2445	VE-04R3645
152.4 (6)	VE-06R845	VE-06R1245	VE-06R2445	VE-06R3645
228.9 (9)	VE-09R845	VE-09R1245	VE-09R2445	VE-09R3645
304.8 (12)	VE-12R845	VE-12R1245	VE-12R2445	VE-12R3645
406.4 (16)	VE-16R845	VE-16R1245	VE-16R2445	VE-16R3645
457.2 (18)	VE-18R845	VE-18R1245	VE-18R2445	VE-18R3645
508.0 (20)	VE-20R845	VE-20R1245	VE-20R2445	VE-20R3645
609.6 (24)	VE-24R845	VE-24R1245	VE-24R2445	VE-24R3645
762.0 (30)	VE-30R845	VE-30R1245	VE-30R2445	VE-30R3645
914.4 (36)	VE-36R845	VE-36R1245	VE-36R2445	VE-36R3645

INCLUYE 2 CONECTORES Y TORNILLERIA / TWO CONNECTORS AND HARDWARE INCLUDED

TODAS LAS DIMENSIONES EN mm (Pulg) / ALL DIMENSIONS ARE IN mm (Inch)

PUEDEN SER SUJETOS A MODIFICACION SIN PREVIO AVISO / MAY BE SUBJECT TO MODIFICATION WITHOUT NOTICE

CURVA VERTICAL INTERIOR A 45° Y 90°

45° & 90° INSIDE VERTICAL BEND

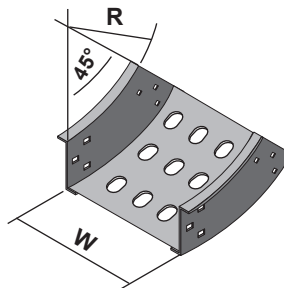
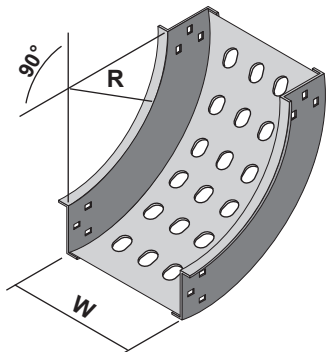

VIZP-12R890-1GI

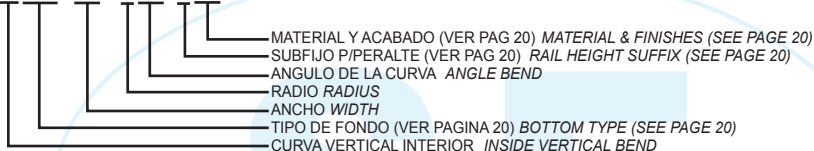

NUMEROS DE CATALOGO PARA CURVA A 90° 90° BEND CATALOG NUMBER

ANCHO W WIDTH W	RADIO RADIUS			
	203.2 (8)	304.8 (12)	609.6 (24)	914.4 (36)
101.6 (4)	VI-04R890	VI-04R1290	VI-04R2490	VI-04R3690
152.4 (6)	VI-06R890	VI-06R1290	VI-06R2490	VI-06R3690
228.9 (9)	VI-09R890	VI-09R1290	VI-09R2490	VI-09R3690
304.8 (12)	VI-12R890	VI-12R1290	VI-12R2490	VI-12R3690
406.4 (16)	VI-16R890	VI-16R1290	VI-16R2490	VI-16R3690
457.2 (18)	VI-18R890	VI-18R1290	VI-18R2490	VI-18R3690
508.0 (20)	VI-20R890	VI-20R1290	VI-20R2490	VI-20R3690
609.6 (24)	VI-24R890	VI-24R1290	VI-24R2490	VI-24R3690
762.0 (30)	VI-30R890	VI-30R1290	VI-30R2490	VI-30R3690
914.4 (36)	VI-36R890	VI-36R1290	VI-36R2490	VI-36R3690

NUMEROS DE CATALOGO PARA CURVA A 45° 45° BEND CATALOG NUMBER

ANCHO W WIDTH W	RADIO RADIUS			
	203.2 (8)	304.8 (12)	609.6 (24)	914.4 (36)
101.6 (4)	VI-04R845	VI-04R1245	VI-04R2445	VI-04R3645
152.4 (6)	VI-06R845	VI-06R1245	VI-06R2445	VI-06R3645
228.9 (9)	VI-09R845	VI-09R1245	VI-09R2445	VI-09R3645
304.8 (12)	VI-12R845	VI-12R1245	VI-12R2445	VI-12R3645
406.4 (16)	VI-16R845	VI-16R1245	VI-16R2445	VI-16R3645
457.2 (18)	VI-18R845	VI-18R1245	VI-18R2445	VI-18R3645
508.0 (20)	VI-20R845	VI-20R1245	VI-20R2445	VI-20R3645
609.6 (24)	VI-24R845	VI-24R1245	VI-24R2445	VI-24R3645
762.0 (30)	VI-30R845	VI-30R1245	VI-30R2445	VI-30R3645
914.4 (36)	VI-36R845	VI-36R1245	VI-36R2445	VI-36R3645

INCLUYE 2 CONECTORES Y TORNILLERIA / TWO CONNECTORS AND HARDWARE INCLUDED

TODAS LAS DIMENSIONES EN mm (Pulg) / ALL DIMENSIONS ARE IN mm (Inch)

PUEDEN SER SUJETOS A MODIFICACION SIN PREVIO AVISO / MAY BE SUBJECT TO MODIFICATION WITHOUT NOTICE

T HORIZONTAL

HORIZONTAL TEE

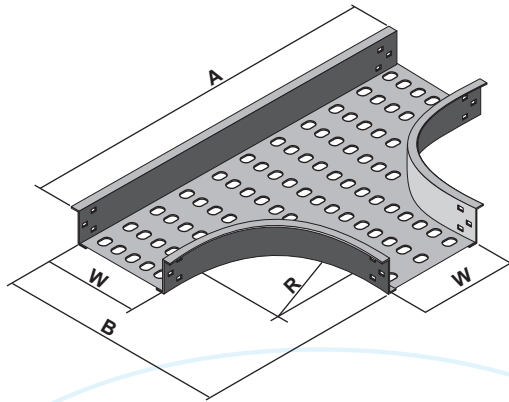

THZL-12R8-1GI

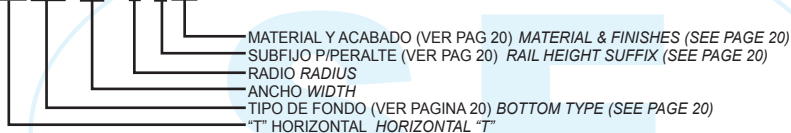

ANCHO W WIDTH W	RADIO 203.2 RADIUS (8) SOLO RADIAL RADIAL ONLY			RADIO 304.8 RADIUS (12)		
	No DE CATALOGO CATALOG NUMBER	A	B	No DE CATALOGO CATALOG NUMBER	A	B
101.6 (4)	TH-04R8	731 (28.78)	416 (16.39)	TH-04R12	864 (34)	518 (20.39)
152.4 (6)	TH-06R8	782 (30.78)	467 (18.39)	TH-06R12	914 (36)	569 (22.39)
228.9 (9)	TH-09R8	585 (23.03)	543 (21.39)	TH-09R12	991 (39)	645 (25.39)
304.8 (12)	TH-12R8	934 (36.78)	619 (24.39)	TH-12R12	1137 (44.78)	721 (28.39)
406.4 (16)	TH-16R8	1036 (40.78)	721 (28.39)	TH-16R12	1239 (48.78)	823 (32.39)
457.2 (18)	TH-18R8	1086 (42.78)	772 (30.39)	TH-18R12	1290 (50.78)	873 (34.39)
508.0 (20)	TH-20R8	1137 (44.78)	823 (32.39)	TH-20R12	1341 (52.78)	924 (36.39)
609.6 (24)	TH-24R8	1239 (48.78)	924 (36.39)	TH-24R12	1442 (56.78)	1026 (40.39)
762.0 (30)	TH-30R8	1391 (54.78)	1077 (42.39)	TH-30R12	1595 (62.78)	1178 (46.39)
914.4 (36)	TH-36R8	1543 (60.78)	1229 (48.39)	TH-36R12	1747 (68.78)	1331 (52.39)

ANCHO W WIDTH W	RADIO 609.6 RADIUS (24)			RADIO 914.4 RADIUS (36)		
	No DE CATALOGO CATALOG NUMBER	A	B	No DE CATALOGO CATALOG NUMBER	A	B
101.6 (4)	TH-04R24	1544 (60.78)	823 (32.39)	TH-04R36	2153 (84.78)	1127 (44.39)
152.4 (6)	TH-06R24	1595 (62.78)	873 (34.39)	TH-06R36	2204 (86.78)	1178 (46.39)
228.9 (9)	TH-09R24	1671 (65.78)	950 (37.39)	TH-09R36	2280 (89.78)	1254 (49.39)
304.8 (12)	TH-12R24	1747 (68.78)	1030 (40.39)	TH-12R36	2357 (92.78)	1331 (52.39)
406.4 (16)	TH-16R24	1849 (72.78)	1127 (44.39)	TH-16R36	2458 (96.78)	1432 (56.39)
457.2 (18)	TH-18R24	1899 (74.78)	1178 (46.39)	TH-18R36	2509 (98.78)	1483 (58.39)
508.0 (20)	TH-20R24	1950 (76.78)	1229 (48.39)	TH-20R36	2560 (100.78)	1534 (60.39)
609.6 (24)	TH-24R24	2052 (80.78)	1331 (52.39)	TH-24R36	2661 (104.78)	1635 (64.39)
762.0 (30)	TH-30R24	2204 (86.78)	1483 (58.39)	TH-30R36	2814 (110.78)	1788 (70.39)
914.4 (36)	TH-36R24	2357 (92.78)	1635 (64.39)	TH-36R36	2966 (116.78)	1940 (76.39)

INCLUYE 2 CONECTORES Y TORNILLERIA / TWO CONNECTORS AND HARDWARE INCLUDED

TODAS LAS DIMENSIONES EN mm (Pulg) / ALL DIMENSIONS ARE IN mm (Inch)

PUEDEN SER SUJETOS A MODIFICACION SIN PREVIO AVISO / MAY BE SUBJECT TO MODIFICATION WITHOUT NOTICE

"X" HORIZONTAL

HORIZONTAL CROSS

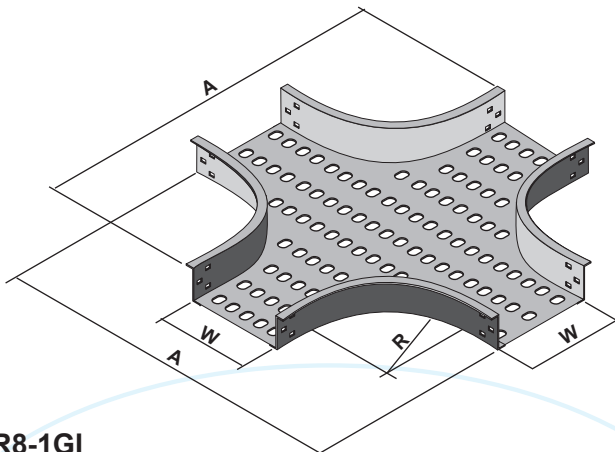

XHZL-12R8-1GI

- MATERIAL Y ACABADO (VER PAG 20) MATERIAL & FINISHES (SEE PAGE 20)
- SUBFIJO P/PERALTE (VER PAG 20) RAIL HEIGHT SUFFIX (SEE PAGE 20)
- RADIO RADIUS
- ANCHO WIDTH
- TIPO DE FONDO (VER PAGINA 20) BOTTOM TYPE (SEE PAGE 20)
- "X" HORIZONTAL HORIZONTAL CROSS

ANCHO W WIDTH W	RADIO 203.2 RADIUS (8)		RADIO 304.8 RADIUS (12)	
	No DE CATALOGO CATALOG NUMBER	A	No DE CATALOGO CATALOG NUMBER	A
101.6 (4)	XH-04R8	731 (28.78)	XH-04R12	864 (34)
152.4 (6)	XH-06R8	782 (30.78)	XH-06R12	914 (36)
228.9 (9)	XH-09R8	585 (23.03)	XH-09R12	991 (39)
304.8 (12)	XH-12R8	934 (36.78)	XH-12R12	1137 (44.78)
406.4 (16)	XH-16R8	1036 (40.78)	XH-16R12	1239 (48.78)
457.2 (18)	XH-18R8	1086 (42.78)	XH-18R12	1290 (50.78)
508.0 (20)	XH-20R8	1137 (44.78)	XH-20R12	1341 (52.78)
609.6 (24)	XH-24R8	1239 (48.78)	XH-24R12	1442 (56.78)
762.0 (30)	XH-30R8	1391 (54.78)	XH-30R12	1595 (62.78)
914.4 (36)	XH-36R8	1543 (60.78)	XH-36R12	1747 (68.78)

ANCHO W WIDTH W	RADIO 609.6 RADIUS (24)		RADIO 914.4 RADIUS (36)	
	No DE CATALOGO CATALOG NUMBER	A	No DE CATALOGO CATALOG NUMBER	A
101.6 (4)	XH-04R24	1544 (60.78)	XH-04R36	2153 (84.78)
152.4 (6)	XH-06R24	1595 (62.78)	XH-06R36	2204 (86.78)
228.9 (9)	XH-09R24	1671 (65.78)	XH-09R36	2280 (89.78)
304.8 (12)	XH-12R24	1747 (68.78)	XH-12R36	2357 (92.78)
406.4 (16)	XH-16R24	1849 (72.78)	XH-16R36	2458 (96.78)
457.2 (18)	XH-18R24	1899 (74.78)	XH-18R36	2509 (98.78)
508.0 (20)	XH-20R24	1950 (76.78)	XH-20R36	2560 (100.78)
609.6 (24)	XH-24R24	2052 (80.78)	XH-24R36	2661 (104.78)
762.0 (30)	XH-30R24	2204 (86.78)	XH-30R36	2814 (110.78)
914.4 (36)	XH-36R24	2357 (92.78)	XH-36R36	2966 (116.78)

INCLUYE 2 CONECTORES Y TORNILLERIA / TWO CONNECTORS AND HARDWARE INCLUDED
 TODAS LAS DIMENSIONES EN mm (Pulg) / ALL DIMENSIONS ARE IN mm (Inch)
 PUEDE SER SUJETO A MODIFICACION SIN PREVIO AVISO / MAY BE SUBJECT TO MODIFICATION WITHOUT NOTICE

T VERTICAL

VERTICAL TEE

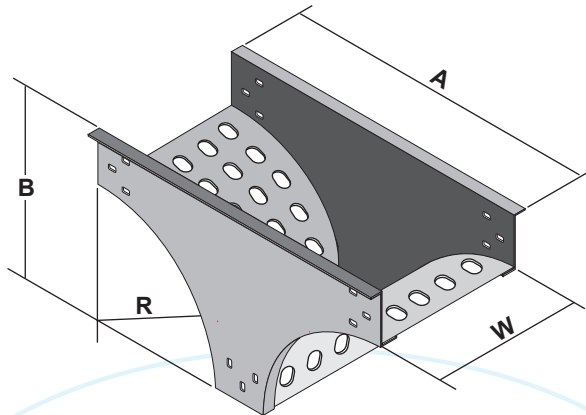

TVZP-12R8-1GI

- MATERIAL Y ACABADO (VER PAG 20) MATERIAL & FINISHES (SEE PAGE 20)
- SUBFIJO P/PERALTE (VER PAG 20) RAIL HEIGHT SUFFIX (SEE PAGE 20)
- RADIO RADIUS
- ANCHO WIDTH
- TIPO DE FONDO (VER PAGINA 20) BOTTOM TYPE (SEE PAGE 20)
- "T" VERTICAL VERTICAL "T"

NUMEROS DE CATALOGO CATALOG NUMBER

ANCHO W WIDTH W	RADIO RADIUS			
	203.2 (8)	304.8 (12)	609.6 (24)	914.4 (36)
101.6 (4)	TV-04R8	TV-04R12	TV-04R24	TV-04R36
152.4 (6)	TV-06R8	TV-06R12	TV-06R24	TV-06R36
228.9 (9)	TV-09R8	TV-09R12	TV-09R24	TV-09R36
304.8 (12)	TV-12R8	TV-12R12	TV-12R24	TV-12R36
406.4 (16)	TV-16R8	TV-16R12	TV-16R24	TV-16R36
457.2 (18)	TV-18R8	TV-18R12	TV-18R24	TV-18R36
508.0 (20)	TV-20R8	TV-20R12	TV-20R24	TV-20R36
609.6 (24)	TV-24R8	TV-24R12	TV-24R24	TV-24R36
762.0 (30)	TV-30R8	TV-30R12	TV-30R24	TV-30R36
914.4 (36)	TV-36R8	TV-36R12	TV-36R24	TV-36R36

SUBFIJO P/PERALTE HEIGHT RAIL SUFFIX	RADIO RADIUS							
	203.2 (8)		304.8 (12)		609.6 (24)		914.4 (36)	
	A	B	A	B	A	B	A	B
1	489 (19.25)	286 (11.25)	692 (27.25)	387 (15.25)	1302 (51.25)	692 (27.25)	1911 (75.25)	997 (39.25)
2	508 (20)	305 (12)	711 (28)	406 (16)	1321 (52)	711 (28)	1930 (76)	1016 (40)
3	521 (20.5)	318 (12.5)	724 (28.5)	419 (16.5)	1334 (52.5)	724 (28.5)	1943 (76.5)	1029 (40.5)
5	533 (21)	330 (13)	737 (29)	432 (17)	1346 (53)	737 (29)	1956 (77)	1041 (41)
6	559 (22)	356 (14)	762 (30)	457 (18)	1372 (54)	762 (30)	1981 (78)	1067 (42)

INCLUYE 2 CONECTORES Y TORNILLERIA / TWO CONNECTORS AND HARDWARE INCLUDED

TODAS LAS DIMENSIONES EN mm (Pulg) / ALL DIMENSIONS ARE IN mm (Inch)

PUEDO SER SUJETO A MODIFICACION SIN PREVIO AVISO / MAY BE SUBJECT TO MODIFICATION WITHOUT NOTICE

CURVA HORIZONTAL AJUSTABLE

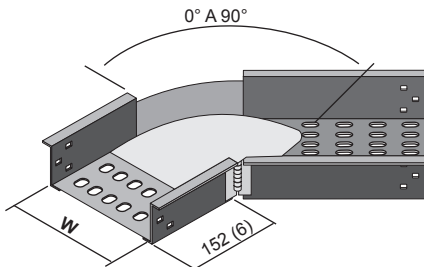

HORIZONTAL ADJUSTABLE BEND

ANCHO W WIDTH W	N° DE CATALOGO CATALOG NUMBER
101.6 (4)	CA-04
152.4 (6)	CA-06
228.9 (9)	CA-09
304.8 (12)	CA-12
406.4 (16)	CA-16
457.2 (18)	CA-18
508.0 (20)	CA-20
609.6 (24)	CA-24
762.0 (30)	CA-30
914.4 (36)	CA-36

INCLUYE 2 CONECTORES Y TORNILLERIA
TWO CONNECTORS AND HARDWARE INCLUDED

NO INCLUYE CINTAS CONDUCTORAS
BONDING JUMPERS NOT INCLUDED

CAZP-12-1GI

- MATERIAL Y ACABADO (VER PAG 20) MATERIAL & FINISHES (SEE PAGE 20)
- SUBFIJO P/PERALTE (VER PAG 20) RAIL HEIGHT SUFFIX (SEE PAGE 20)
- ANCHO WIDTH
- TIPO DE FONDO (VER PAGINA 20) BOTTOM TYPE (SEE PAGE 20)
- CURVA HORIZONTAL AJUSTABLE HORIZONTAL ADJUSTABLE BEND

DERIVACION HORIZONTAL A 45°

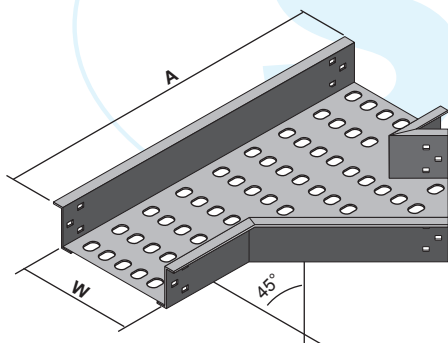

45° HORIZONTAL WYE

ANCHO W WIDTH W	N° DE CATALOGO CATALOG NUMBER	A
101.6 (4)	DY-04	463 (18.2)
152.4 (6)	DY-06	534 (21)
228.9 (9)	DY-09	642 (25.3)
304.8 (12)	DY-12	750 (29.5)
406.4 (16)	DY-16	894 (35.2)
457.2 (18)	DY-18	966 (38)
508.0 (20)	DY-20	1037 (40.8)
609.6 (24)	DY-24	1181 (46.5)
762.0 (30)	DY-30	1396 (55)
914.4 (36)	DY-36	1612 (63.5)

INCLUYE 2 CONECTORES Y TORNILLERIA
TWO CONNECTORS AND HARDWARE INCLUDED

DYZP-12-1GI

- MATERIAL Y ACABADO (VER PAG 20) MATERIAL & FINISHES (SEE PAGE 20)
- SUBFIJO P/PERALTE (VER PAG 20) RAIL HEIGHT SUFFIX (SEE PAGE 20)
- ANCHO WIDTH
- TIPO DE FONDO (VER PAGINA 20) BOTTOM TYPE (SEE PAGE 20)
- DERIVACION HORIZONTAL A 45° 45° HORIZONTAL WYE

TODAS LAS DIMENSIONES EN mm (Pulg) / ALL DIMENSIONS ARE IN mm (Inch)
PUEDE SER SUJETO A MODIFICACION SIN PREVIO AVISO / MAY BE SUBJECT TO MODIFICATION WITHOUT NOTICE

PRODUCTOS SOPORTES ELECTRICOS

REDUCCIONES

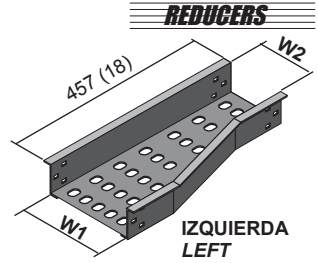
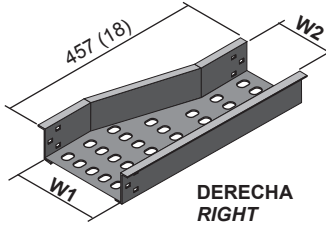
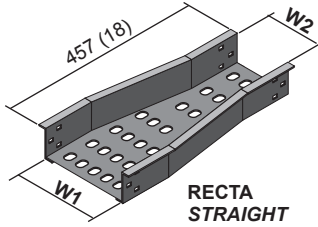

REDUCERS

RLZL-1209-1GI

- MATERIAL Y ACABADO (VER PAG 20) / MATERIAL & FINISHES (SEE PAGE 20)
- SUBFIJO P/PERALTE (VER PAG 20) / RAIL HEIGHT SUFFIX(SEE PAGE 20)
- ANCHO MENOR / SMALLER WIDTH
- ANCHO MAYOR / LARGER WIDTH
- TIPO DE FONDO (VER PAGINA 20) / BOTTOM TYPE (SEE PAGE 20)
- REDUCCION REDUCER
- RL = RECTA / STRAIGHT
- RLD = DERECHA / RIGHT
- RLI = IZQUIERDA / LEFT

N° DE CATALOGO REDUCCIONES RECTAS STRAIGHT REDUCER CATALOG NUMBER

ANCHO W1 WIDTH W1	ANCHO MENOR W2 SMALLER WIDTH W2								
	101.6 (4)	152.4 (6)	228.9 (9)	304.8 (12)	406.4 (16)	457.2 (18)	508.0 (20)	609.6 (24)	762.0 (36)
152.4 (6)	RL-0604								
228.9 (9)	RL-0904	RL-0906							
304.8 (12)	RL-1204	RL-1206	RL-1209						
406.4 (16)	RL-1604	RL-1606	RL-1609	RL-1612					
457.2 (18)	RL-1804	RL-1806	RL-1809	RL-1812	RL-1816				
508.0 (20)	RL-2004	RL-2006	RL-2009	RL-2012	RL-2016	RL-2018			
609.6 (24)	RL-2404	RL-2406	RL-2409	RL-2412	RL-2416	RL-2418	RL-2420		
762.0 (30)	RL-3004	RL-3006	RL-3009	RL-3012	RL-3016	RL-3018	RL-3020	RL-3024	
914.4 (36)	RL-3604	RL-3606	RL-3609	RL-3612	RL-3616	RL-3618	RL-3620	RL-3624	RL-3630

N° DE CATALOGO REDUCCIONES DERECHAS RIGHT REDUCER CATALOG NUMBER

ANCHO W1 WIDTH W1	ANCHO MENOR W2 SMALLER WIDTH W2								
	101.6 (4)	152.4 (6)	228.9 (9)	304.8 (12)	406.4 (16)	457.2 (18)	508.0 (20)	609.6 (24)	762.0 (36)
152.4 (6)	RLD-0604								
228.9 (9)	RLD-0904	RLD-0906							
304.8 (12)	RLD-1204	RLD-1206	RLD-1209						
406.4 (16)	RLD-1604	RLD-1606	RLD-1609	RLD-1612					
457.2 (18)	RLD-1804	RLD-1806	RLD-1809	RLD-1812	RLD-1816				
508.0 (20)	RLD-2004	RLD-2006	RLD-2009	RLD-2012	RLD-2016	RLD-2018			
609.6 (24)	RLD-2404	RLD-2406	RLD-2409	RLD-2412	RLD-2416	RLD-2418	RLD-2420		
762.0 (30)	RLD-3004	RLD-3006	RLD-3009	RLD-3012	RLD-3016	RLD-3018	RLD-3020	RLD-3024	
914.4 (36)	RLD**-3604	RLD-3606	RLD-3609	RLD-3612	RLD-3616	RLD-3618	RLD-3620	RLD-3624	RLD-3630

N° DE CATALOGO REDUCCIONES IZQUIERDAS LEFT REDUCER CATALOG NUMBER

ANCHO W1 WIDTH W1	ANCHO MENOR W2 SMALLER WIDTH W2								
	101.6 (4)	152.4 (6)	228.9 (9)	304.8 (12)	406.4 (16)	457.2 (18)	508.0 (20)	609.6 (24)	762.0 (36)
152.4 (6)	RLI-0604								
228.9 (9)	RLI-0904	RLI-0906							
304.8 (12)	RLI-1204	RLI-1206	RLI-1209						
406.4 (16)	RLI-1604	RLI-1606	RLI-1609	RLI-1612					
457.2 (18)	RLI-1804	RLI-1806	RLI-1809	RLI-1812	RLI-1816				
508.0 (20)	RLI-2004	RLI-2006	RLI-2009	RLI-2012	RLI-2016	RLI-2018			
609.6 (24)	RLI-2404	RLI-2406	RLI-2409	RLI-2412	RLI-2416	RLI-2418	RLI-2420		
762.0 (30)	RLI-3004	RLI-3006	RLI-3009	RLI-3012	RLI-3016	RLI-3018	RLI-3020	RLI-3024	
914.4 (36)	RLI**-3604	RLI-3606	RLI-3609	RLI-3612	RLI-3616	RLI-3618	RLI-3620	RLI-3624	RLI-3630

INCLUDE 2 CONECTORES Y TORNILLERIA / TWO CONNECTORS AND HARDWARE INCLUDED

TODAS LAS DIMENSIONES EN mm (Pulg) / ALL DIMENSIONS ARE IN mm (Inch)

PUEDEN SER SUJETOS A MODIFICACION SIN PREVIO AVISO / MAY BE SUBJECT TO MODIFICATION WITHOUT NOTICE



SECCION 1.3 ACCESORIOS DE ENSAMBLE PARA CHAROLAS TIPO ESCALERA Y FONDO SOLIDO

SECTION 1.3 ASSEMBLY FITTING FOR CABLE TRAY SYSTEM LADDER AND SOLID BOTTOM TYPE

CONECTOR TIPO "Z"

FORM "Z" SPLICE PLATE

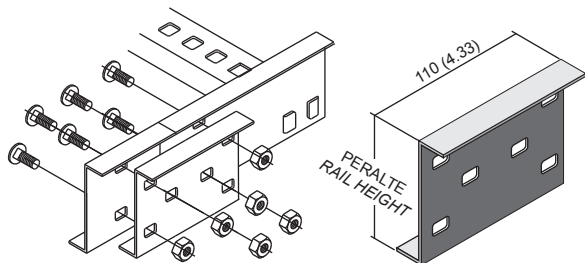

AZ-1GI

MATERIAL Y ACABADO (VER PAG 20)
 MATERIAL & FINISHES (SEE PAGE 20)
 SUBFIJO P/PERALTE (VER PAG 20)
 RAIL HEIGHT SUFFIX (SEE PAGE 20)
 CONECTOR TIPO Z FORM Z CONNECTOR

APLICABLE SOLO PARA PRODUCTOS PERFIL TIPO Z
 USE ONLY WITH PRODUCTS Z RAIL SIDE FORM

TORNILLERIA INCLUIDA
 HARDWARE INCLUDED

CONECTOR RECTO

STRAIGHT SPLICE PLATE

AR-1GI

MATERIAL Y ACABADO (VER PAG 20)
 MATERIAL & FINISHES (SEE PAGE 20)
 SUBFIJO P/PERALTE (VER PAG 20)
 RAIL HEIGHT SUFFIX (SEE PAGE 20)
 CONECTOR RECTO / STRAIGHT CONNECTOR

TORNILLERIA INCLUIDA
 HARDWARE INCLUDED

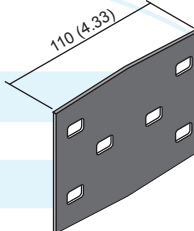

CONECTOR FORMA L

FORM "L" SPLICE PLATE

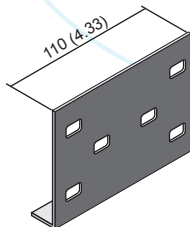

AL-1GI

MATERIAL Y ACABADO (VER PAG 20)
 MATERIAL & FINISHES (SEE PAGE 20)
 SUBFIJO P/PERALTE (VER PAG 20)
 RAIL HEIGHT SUFFIX (SEE PAGE 20)
 CONECTOR FORMAL / FORM L CONNECTOR

TORNILLERIA INCLUIDA
 HARDWARE INCLUDED

CONECTOR DE EXPANSION

EXPANSION CONNECTOR

AEZ-1GI

MATERIAL Y ACABADO (VER PAG 20)
 MATERIAL & FINISHES (SEE PAGE 20)
 SUBFIJO P/PERALTE (VER PAG 20)
 RAIL HEIGHT SUFFIX (SEE PAGE 20)
 CONECTOR DE EXPANSION / EXPANSION CONNECTOR

PARA UNA EXPANSION DE 25.4mm (1") / FOR AN EXPANSION OF 25.4 mm (1")

NO INCLUYE CINTAS CONDUCTORAS / BONDING JUMPERS NOT INCLUDED

TORNILLERIA INCLUIDA / HARDWARE INCLUDED

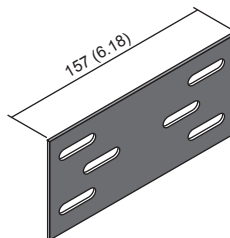

TODAS LAS DIMENSIONES EN mm (Pulg) / ALL DIMENSIONS ARE IN mm (Inch)
 PUEDE SER SUJETO A MODIFICACION SIN PREVIO AVISO / MAY BE SUBJECT TO MODIFICATION WITHOUT NOTICE



ELEVADOR AJUSTABLE

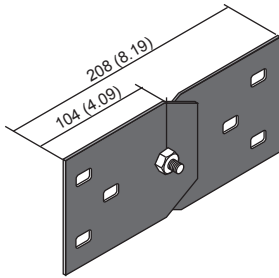

VERTICAL ADJUSTABLE CONNECTOR

EA-1GI

- MATERIAL Y ACABADO (VER PAG 20)
- MATERIAL & FINISHES (SEE PAGE 20)
- SUBFIJO P/PERALTE (VER PAG 20)
- RAIL HEIGHT SUFFIX (SEE PAGE 20)
- ELEVADOR AJUSTABLE / VERTICAL ADJUSTABLE CONNECTOR

NO INCLUYE CINTAS CONDUCTORAS / BONDING JUMPERS NOT INCLUDED

TORNILLERIA INCLUIDA / HARDWARE INCLUDED

CONECTOR HORIZONTAL AJUSTABLE

HORIZONTAL ADJUSTABLE CONNECTOR

AH-1GI

- MATERIAL Y ACABADO (VER PAG 20)
- MATERIAL & FINISHES (SEE PAGE 20)
- SUBFIJO P/PERALTE (VER PAG 20)
- RAIL HEIGHT SUFFIX (SEE PAGE 20)
- CONECTOR HORIZONTAL AJUSTABLE
- HORIZONTAL ADJUSTABLE CONNECTOR

NO INCLUYE CINTAS CONDUCTORAS / BONDING JUMPERS NOT INCLUDED

TORNILLERIA INCLUIDA / HARDWARE INCLUDED

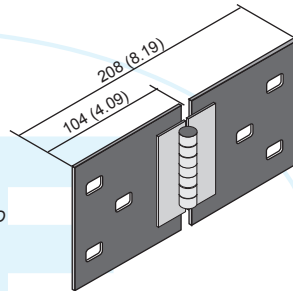

CONECTOR REDUCTOR

REDUCER CONNECTOR

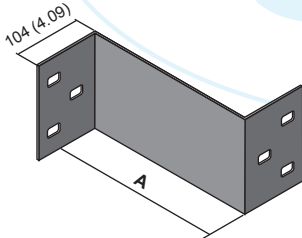

ARR-19.5-1GI

- MATERIAL Y ACABADO (VER PAG 20)
- MATERIAL & FINISHES (SEE PAGE 20)
- SUBFIJO P/PERALTE (VER PAG 20)
- RAIL HEIGHT SUFFIX (SEE PAGE 20)
- DIFERENCIA DE ANCHOS VER NOTA 1
- WIDTH DIFFERENCE SEE NOTE 1
- CONECTOR REDUCTOR / REDUCER CONNECTOR

TORNILLERIA INCLUIDA / HARDWARE INCLUDED

NOTA 1

PARA REDUCCIONES RECTAS SE DEBERA RESTAR EL ANCHO MAYOR MENOS EL ANCHO MENOR Y DIVIDIR ENTRE 2, POR EJEMPLO SI LA CHAROLA MAYOR MIDE 24" Y LA MENOR 12", LA DIFERENCIA DE ANCHOS SERA DE 6", POR LO TANTO SE DEBERAN SOLICITAR 2 CONECTORES ARR-6.

PARA REDUCCIONES LATERALES SE DEBERA RESTAR EL ANCHO MAYOR MENOS EL ANCHO MENOR, POR EJEMPLO SI LA CHAROLA MAYOR MIDE 24" Y LA MENOR 12" LA DIFERENCIA DE ANCHOS SERA DE 12", POR LO TANTO SE DEBERA SOLICITAR UN SOLO CONECTOR ARR-12, Y UN CONECTOR RECTO.

NOTE 1.-

FOR STRAIGHT REDUCER YOU SHOULD SUBSTRACT THE LARGER WIDTH MINUS SMALLER WIDTH AND DIVIDE BETWEEN TWO, FOR EXAMPLE IF THE LARGER WIDTH IS 24" AND THE SMALER WIDTH IS 12" THE WIDTH DIFFERENCE WILL BE 6", SO YOU SHOULD REQUEST TWO CONNECTORS ARR-6

FOR LEFT & RIGHT REDUCER YOU SHOULD SUBSTRACT THE LARGER WIDTH MINUS SMALLER WIDTH, FOR EXAMPLE IF THE LARGER WIDTH IS 24" AND THE SMALER WIDTH IS 12" THE WIDTH DIFFERENCE WILL BE 12", SO YOU SHOULD REQUEST ONLY ONE CONNECTOR

TODAS LAS DIMENSIONES EN mm (Pulg) / ALL DIMENSIONS ARE IN mm (Inch)

PUEDE SER SUJETO A MODIFICACION SIN PREVIO AVISO / MAY BE SUBJECT TO MODIFICATION WITHOUT NOTICE

TAPA TERMINAL

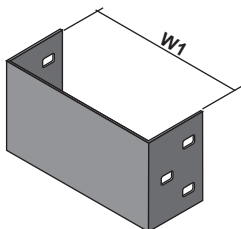

PTR-09-1GI

- MATERIAL Y ACABADO (VER PAG 20) / MATERIAL & FINISHES (SEE PAGE 20)
- SUBFIJO P/PERALTE (VER PAG 20) / RAILHEIGHT SUFFIX (SEE PAGE 20)
- ANCHO DE LA CHAROLA / CABLE TRAY WIDTH
- TAPA TERMINAL / BLIND END

BLIND END

ANCHO DE CHAROLA TRAY WIDTH	W 1
101.6 (4)	106(4.19)
152.4 (6)	157 (6.19)
228.9 (9)	233 (6.19)
304.8 (12)	309 (12.19)
406.4 (16)	411 (16.19)
457.2 (18)	462 (18.19)
508.0 (20)	513 (20.19)
609.6 (24)	614 (24.19)
762.0 (30)	767 (30.19)
914.4 (36)	919 (36.19)

TORNILLERIA INCLUIDA
HARDWARE INCLUDED

CONECTOR DE CHAROLA A CAJA

ANCHO DE CHAROLA TRAY WIDTH	W 1
101.6 (4)	106(4.19)
152.4 (6)	157 (6.19)
228.9 (9)	233 (6.19)
304.8 (12)	309 (12.19)
406.4 (16)	411 (16.19)
457.2 (18)	462 (18.19)
508.0 (20)	513 (20.19)
609.6 (24)	614 (24.19)
762.0 (30)	767 (30.19)
914.4 (36)	919 (36.19)

TORNILLERIA INCLUIDA
HARDWARE INCLUDED

FRAME TYPE BOX CONNECTOR

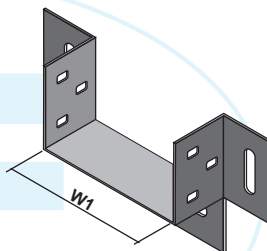

ACC-09-1GI

- MATERIAL Y ACABADO (VER PAG 20) / MATERIAL & FINISHES (SEE PAGE 20)
- SUBFIJO P/PERALTE (VER PAG 20) / RAILHEIGHT SUFFIX (SEE PAGE 20)
- ANCHO DE LA CHAROLA / CABLE TRAY WIDTH
- CONECTOR CHAROLA A CAJA / FRAME TYPE BOX CONNECTOR

BAJADA PARA CABLE

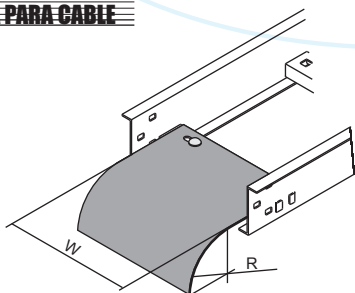

DROP-OUT

ANCHO DE CHAROLA TRAY WIDTH	RADIO 50.8 (2) RADIUS 50.8 (2)	RADIO 127 (5) RADIUS 127 (5)
101.6 (4)	BC-204	BC-504
152.4 (6)	BC-206	BC-506
228.9 (9)	BC-209	BC-509
304.8 (12)	BC-212	BC-512
406.4 (16)	BC-216	BC-516
457.2 (18)	BC-218	BC-518
508.0 (20)	BC-220	BC-520
609.6 (24)	BC-224	BC-524
762.0 (30)	BC-230	BC-530
914.4 (36)	BC-236	BC-536

BC-509-1GI

- MATERIAL Y ACABADO (VER PAG 20) / MATERIAL & FINISHES (SEE PAGE 20)
- SUBFIJO P/PERALTE (VER PAG 20) / RAILHEIGHT SUFFIX (SEE PAGE 20)
- ANCHO DE LA CHAROLA / CABLE TRAY WIDTH
- RADIO DE LA BAJADA / DROP-OUT RADIUS
- BAJADA PARA CABLES / DROP-OUT

TORNILLERIA NO INCLUIDA
HARDWARE NOT INCLUDED

TODAS LAS DIMENSIONES EN mm (Pulg) / ALL DIMENSIONS ARE IN mm (Inch)
 PUEDE SER SUJETO A MODIFICACION SIN PREVIO AVISO / MAY BE SUBJECT TO MODIFICATION WITHOUT NOTICE

BARRERAS SEPARADORAS TRAMO RECTO

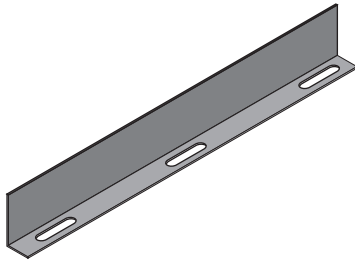

BSCH-3.05-1GI

- MATERIAL Y ACABADO (VER PAG 20)
- MATERIAL & FINISHES (SEE PAGE 20)
- SUBFIJO P/PERALTE (VER PAG 20)
- RAIL HEIGHT SUFFIX (SEE PAGE 20)
- LONGITUD DE LA CHAROLA EN METROS (DISPONIBLE EN 3.05m Y 3.66m)
- CABLE TRAY LENGHT IN METERS (AVAILABLE IN 3.05m AND 3.66m)
- BARRERA SEPARADORA PARA TRAMO RECTO
- STRAIGHT DIVIDER STRIP

INCLUYE 5 CLEMAS CLAMP-112 CON TORNILLERIA
FIVE HOLD DOWN CLAMP-112 AND HARDWARE INCLUDED



BARRERAS SEPARADORAS CURVAS HORIZONTALES

BSH - 72-1GI

- MATERIAL Y ACABADO (VER PAG 20)
- MATERIAL & FINISHES (SEE PAGE 20)
- SUBFIJO P/PERALTE (VER PAG 20)
- RAIL HEIGHT SUFFIX (SEE PAGE 20)
- LONGITUD DE LA BARRERA EN PULGADAS (DISPONIBLE EN 48" Y 72")
- DIVIDER STRIP LENGHT IN INCHES (AVAILABLE IN 48" AND 72")
- BARRERA SEPARADORA PARA CURVA HORIZONTAL
- HORIZONTAL FITTING DIVIDER STRIP

INCLUYE 3 CLEMAS CLAMP-112 CON TORNILLERIA
THREE HOLD DOWN CLAMP-112 AND HARDWARE INCLUDED

HORIZONTAL FITTINGS DIVIDER STRIP

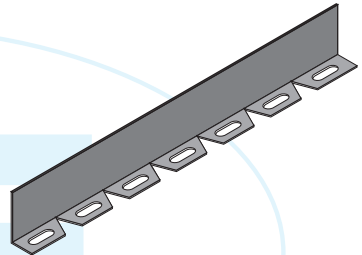

BARRERAS SEPARADORAS CURVAS VERTICALES

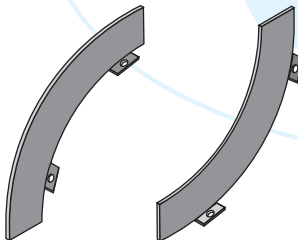

BSVE - R08901GI

VERTICAL FITTINGS DIVIDER STRIP

- No DE CATALOGO DE LA PIEZA A LA QUE SE COLOCARA LA BARRERA.
- CATALOG NUMBER OF THE VERTICAL FITTING
- BARRERA SEPARADORA PARA CURVA VERTICAL
- VERTICAL FITTING DIVIDER STRIP

INCLUYE CLEMAS CLAMP-112 CON TORNILLERIA
HOLD DOWN CLAMP-112 AND HARDWARE INCLUDED

CINTAS CONDUCTORAS

PARA SU SELECCION Y APLICACION CONSULTE NOM-001-SEDE-2012
FOR APPLICATION AND SELECTION, SEE NOM-001-SEDE-2012

BONDING JUMPERS

No DE CATALOGO CATALOG NUMBER	CAPACIDAD CAPACITY	
CC-99NI	600 AMP. MAX.	
CC-9940	1600 AMP. MAX.	
CC-991620	2000 AMP. MAXIMO	

TODAS LAS DIMENSIONES EN mm (Pulg) / ALL DIMENSIONS ARE IN mm (Inch)
PUEDE SER SUJETO A MODIFICACION SIN PREVIO AVISO / MAY BE SUBJECT TO MODIFICATION WITHOUT NOTICE

TAPAS PARA TRAMO RECTO

STRAIGHT COVERS

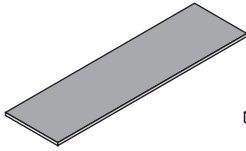

TAPA RECTA TIPO "TR"
FLAT COVER "TR" TYPE

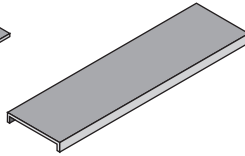

TAPA CON CEJA TIPO "TRC"
FLANGED COVER "TRC" TYPE

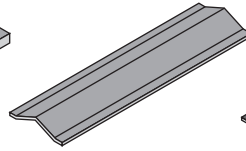

TAPA A DOS AGUAS TIPO "TA"
PEAKED COVER "TA" TYPE

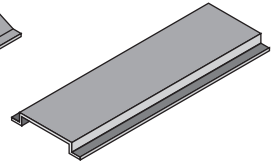

TAPA SOMBRERO TIPO "TSS"
DOMED COVER "TSS" TYPE

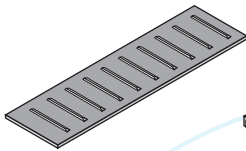

TAPA RECTA CON VENTILACION TIPO "TRV"
FLAT VENTED COVER "TRV" TYPE

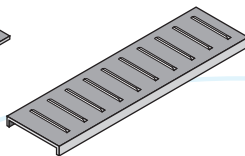

TAPA CON CEJA CON VENTILACION TIPO "TRCV"
FLANGED AND VENTED COVER "TRCV" TYPE

LAS TAPAS SE SURTEN EN JUEGOS DE 3 TAPAS DE 1219 mm (4 FT) E INCLUYEN 12 CLIPS DE SUJECION

PARA OTRAS LONGITUDES CONSULTE NUESTRO DEPARTAMENTO DE INGENIERIA

THE COVER IS SUPPLIED IN SET OF 3 COVERS OF 1219 mm (4 ft) 12 COVER CLAMPS ARE INCLUDED

FOR OTHER LENGHTS PLEASE CONSULT OUR TECHNICAL DEPARTMENT

LAS TAPAS PARA ACCESORIOS SOLO SE FABRICAN EN TIPO RECTO E INCLUYEN CLIPS NECESARIOS.

ONLY FLAT TYPE IS SUPPLIED FOR FITTING COVERS AND COVER CLAMP NEEDED ARE INCLUDED

TRCV-CHCB-12-1GI

No DE CATALOGO DE LA PIEZA A CUBRIR / CATALOG NUMBER OF THE PRODUCT FOR COVER TIPO DE TAPA / COVER TYPE

CLIPS DE SUJECION PARA TAPAS

PARA CHAROLAS PERFILES TIPO "Z", "CA", "CC", E "I"
FOR PRODUCTS WITH RAIL TYPE "Z", "CA", "CC", & "I"

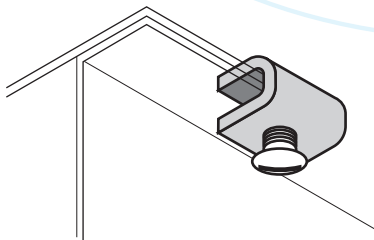

CST-14-GI

MATERIAL Y ACABADO (VER PAG 9)
MATERIAL & FINISHES (SEE PAGE 9)
CLIP NORMAL STANDARD CLAMP

COVER CLAMPS

PARA CHAROLAS PERFILES TIPO "C" Y "CB"
FOR PRODUCTS WITH RAIL TYPE "C" & "CB"

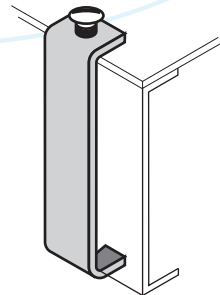

CSTSC-14-1GI

MATERIAL Y ACABADO (VER PAG 9)
MATERIAL & FINISHES (SEE PAGE 9)
SUBFIJO P/PERALTE (VER PAG 9)
RAIL HEIGHT SUFFIX (SEE PAGE 9)
CLIP LARGO LARGE CLAMP

TODAS LAS DIMENSIONES EN mm (Pulg) / ALL DIMENSIONS ARE IN mm (Inch)
PUEDE SER SUJETO A MODIFICACION SIN PREVIO AVISO / MAY BE SUBJECT TO MODIFICATION WITHOUT NOTICE

SECCION 1.4 ACCESORIOS DE MONTAJE

MENSULA PARA MONTAJE EN PARED

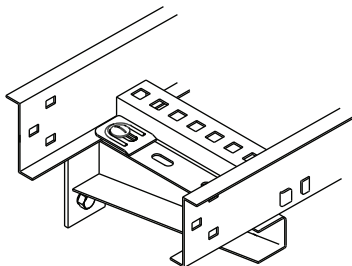

MPPI-09-GI

MATERIAL Y ACABADO / MATERIAL & FINISHES
 ANCHO DE LA CHAROLA / CABLE TRAY WIDTH
 COLOCAR ESTE DIGITO PARA CHAROLAS CON PERFIL TIPO "CC", "IM" E "IP"
 USE THIS LETTER FOR TRAYS WITH RAIL TYPE "CC", "IM" & "IP"
 MENSULA PARA PARED / WALL SUPPORTED BRACKET

SECCION 1.4 SUPPORTS AND BRACKETS

WALL CANTILEVER BRACKET

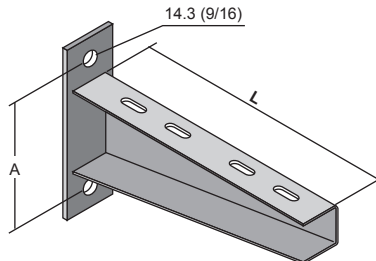

ANCHO DE CHAROLA TRAY WIDTH	A	PARA PERFIL TIPO Z, C (VER PAGINA 9) FOR RAIL TYPE Z, C (SEE PAGE 9)		PARA PERFIL TIPO I (VER PAGINA 9) FOR RAIL TYPE I (SEE PAGE 9)		CARGA SOPORTADA LOAD CAPACITY
		No DE CATALOGO CATALOG NUMBER	L	No DE CATALOGO CATALOG NUMBER	L	
101.6 (4)	120 (4.75)	MPP-04	127 (5)	MPPI-04	152 (6)	705 kg (1550 lb)
152.4 (6)		MPP-06	178 (7)	MPPI-06	203 (8)	665 kg (1460 lb)
228.9 (9)		MPP-09	254 (10)	MPPI-09	279 (11)	645 kg (1420 lb)
304.8 (12)		MPP-12	330 (13)	MPPI-12	356 (14)	550 kg (1215 lb)
406.4 (16)	158 (6.22)	MPP-16	432 (17)	MPPI-16	457 (18)	505 kg (1115 lb)
457.2 (18)		MPP-18	483 (19)	MPPI-18	508 (20)	450 kg (990 lb)
508.0 (20)		MPP-20	533 (21)	MPPI-20	559 (22)	385 kg (850 lb)
609.6 (24)		MPP-24	635 (25)	MPPI-24	660 (26)	325 kg (717 lb)
762.0 (30)		MPP-30	787 (31)	MPPI-30	813 (32)	275 kg (607 lb)
914.4 (36)		MPP-36	940 (37)	MPPI-36	965 (38)	225 kg (496 lb)

LA CARGA SOPORTADA MUESTRA LA CAPACIDAD DE LA MENSULA, SOPORTES ELECTRICOS NO SE HACE RESPONSABLE DE FALLAS ATRIBUIBLES A LOS SISTEMAS DE ANCLAJE O EL SUSTRATO DE APOYO.
 THE LOAD SHOWN INDICATE THE BRACKET LOAD CAPACITY, SOPORTES ELECTRICOS IS NOT RESPONSABLE FOR FAILURES CAUSED BY THE ANCHORING SYSTEM OR FOR THE WALLS MATERIALS

LAS CARGAS SOPORTADAS ESTAN BASADAS EN UN FACTOR DE SEGURIDAD DE 2.5
 THE LOAD CAPACITY ARE WITH A SECURITY FACTOR OF 2.5

NO INCLUYE TORNILLERIA NI SISTEMAS DE FIJACION
 HARDWARE, CLAMP OR ANCHORING SYSTEM ARE NOT INCLUDED

MATERIALES Y ACABADOS DISPONIBLES:

MATERIALS & FINISHES AVAILABLE :

- GI : ACERO AL CARBONO GALVANIZADO POR INMERSION EN CALIENTE SEGUN ASTM A 123
- GE : ACERO AL CARBONO GALVANIZADO ELECTROLITICO SEGUN ASTM B 633
- T : ACERO AL CARBONO TROPICALIZADO
- PVC: ACERO AL CARBONO RECUBIERTO CON PVC SEGUN NEMA RN 1
- AI : ACERO INOXIDABLE ACABADO NATURAL

- GI : HOT DIP GALVANIZED STEEL UNDER ASTM A 123
- GE : ELECTROGALVANIZED STEEL UNDER ASTM B 633
- T : CHROMIUM-ZINC COATED STEEL
- PVC: PVC COATED STEEL UNDER NEMA RN 1
- AI : NATURAL FINISHED STAINLESS STEEL

PARA MATERIALES Y ACABADOS NO INDICADOS CONSULTE NUESTRO DEPARTAMENTO DE INGENIERIA
 FOR MATERIALS AND FINISHES NOT SHOWN. PLEASE CONSULT OUR TECHNICAL DEPARTMENT

TODAS LAS DIMENSIONES EN mm (Pulg) / ALL DIMENSIONS ARE IN mm (Inch)
 PUEDE SER SUJETO A MODIFICACION SIN PREVIO AVISO / MAY BE SUBJECT TO MODIFICATION WITHOUT NOTICE

MENSULA PARA MONTAJE EN CANAL

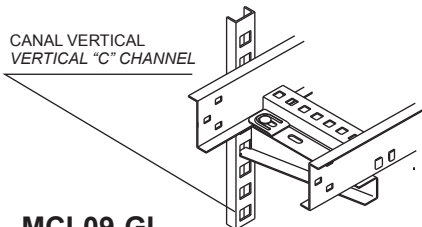

CHANNEL CANTILEVER BRACKET

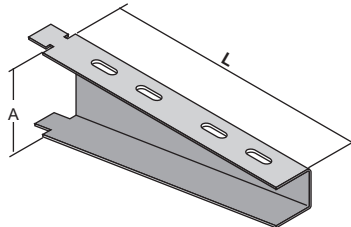

MCI-09-GI

MATERIAL Y ACABADO (VER PAGINA 34) / MATERIAL & FINISHES (SEE PAGE 34)
 ANCHO DE LA CHAROLA / CABLE TRAY WIDTH
 COLOCAR ESTE DIGITO PARA CHAROLAS CON PERFIL TIPO "CC", "IM" E "IP"
 USE THIS LETTER FOR TRAYS WITH RAIL TYPE "CC", "IM" & "IP"
 MENSULA PARA CANAL / CHANNELCANTILEVER BRACKET

ANCHO DE CHAROLA TRAY WIDTH	A	PARA PERFIL TIPO Z, C (VER PAGINA 9) FOR RAIL TYPE Z, C (SEE PAGE 9)		PARA PERFIL TIPO I (VER PAGINA 9) FOR RAIL TYPE I (SEE PAGE 9)		CARGA SOPORTADA LOAD CAPACITY
		No DE CATALOGO CATALOG NUMBER	L	No DE CATALOGO CATALOG NUMBER	L	
101.6 (4)	79 (3.1)	MC-04	127 (5)	MCI-04	152 (6)	345 kg (762 lb)
152.4 (6)		MC-06	178 (7)	MCI-06	203 (8)	325 kg (717 lb)
228.9 (9)		MC-09	254 (10)	MCI-09	279 (11)	315 kg (695 lb)
304.8 (12)		MC-12	330 (13)	MCI-12	356 (14)	270 kg (596 lb)
406.4 (16)	117 (4.6)	MC-16	432 (17)	MCI-16	457 (18)	245 kg (540 lb)
457.2 (18)		MC-18	483 (19)	MCI-18	508 (20)	220 kg (485 lb)
508.0 (20)		MC-20	533 (21)	MCI-20	559 (22)	190 kg (420 lb)
609.6 (24)		MC-24	635 (25)	MCI-24	660 (26)	160 kg (353 lb)
762.0 (30)		MC-30	787 (31)	MCI-30	813 (32)	135 kg (298 lb)
914.4 (36)		MC-36	940 (37)	MCI-36	965 (38)	110 kg (243 lb)

LA CARGA SOPORTADA MUESTRA LA CAPACIDAD DE LA MENSULA EN CONJUNTO CON EL CANAL VERTICAL, SOPORTES ELECTRICOS NO SE HACE RESPONSABLE DE FALLAS ATRIBUIBLES A LOS SISTEMAS DE ANCLAJE O EL SUSTRATO DE APOYO. THE LOAD SHOWN INDICATE THE BRACKET LOAD CAPACITY ASSMBLED WITH VERTICAL CHANNEL, SOPORTES ELECTRICOS IS NOT RESPONSABLE FOR FAILURES CAUSED BY THE ANCHORING SYSTEM OR FOR THE WALLS MATERIALS

LAS CARGAS SOPORTADAS ESTAN BASADAS EN UN FACTOR DE SEGURIDAD DE 2.5
 THE LOAD CAPACITY ARE WITH A SECURITY FACTOR OF 2.5

NO INCLUYE TORNILLERIA NI SISTEMAS DE FIJACION
 HARDWARE, CLAMP OR ANCHORING SYSTEM ARE NOT INCLUDED

CANAL VERTICAL

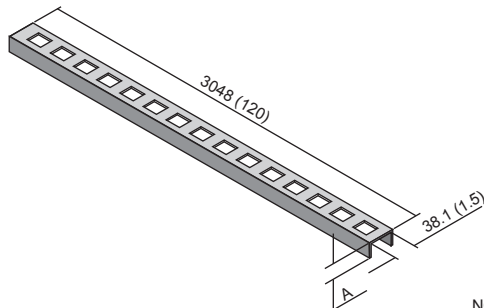

VERTICAL "C" CHANNEL

CVPP-120-GI

MATERIAL Y ACABADO VER PAGINA 34
 MATERIAL & FINISHES SEE PAGE 34
 LONGITUD DEL CANAL EN PULGADAS
 CHANNEL LENGHT IN INCHES
 COLOCAR ESTE DIGITO EN CANALES
 CON ALTURA DE 19 mm (3/4)
 USE THIS LETTER FOR CHANNELS
 WITH 19 (3/4) HEIGHT
 CANAL VERTICAL / VERTICAL "C" CHANNEL

N° DE CATALOGO CATALOG NUMBER	A
CVPP-120	19 (3/4)
CVP-120	38.1 (1.5)

NO INCLUYE TORNILLERIA NI SISTEMAS DE FIJACION
 HARDWARE, CLAMP OR ANCHORING SYSTEM ARE NOT INCLUDED

TODAS LAS DIMENSIONES EN mm (Pulg) / ALL DIMENSIONS ARE IN mm (Inch)
 PUEDE SER SUJETO A MODIFICACION SIN PREVIO AVISO / MAY BE SUBJECT TO MODIFICATION WITHOUT NOTICE

PRODUCTOS SOPORTES ELECTRICOS

CANAL HORIZONTAL PARA TRAPEZCIO

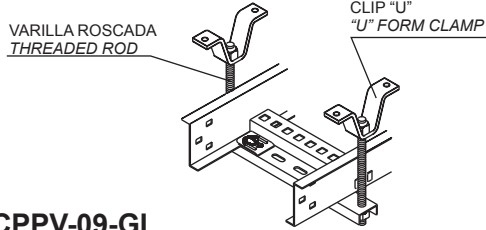

CPPV-09-GI

MATERIAL Y ACABADO (VER PAGINA 34) / MATERIAL & FINISHES (VER PAGINA 34)
 ANCHO DE LA CHAROLA / CABLE TRAY WIDTH
 COLOCAR ESTE DIGITO EN CANALES CON ALTURA DE 19 mm (3/4)
 USE THIS LETTER FOR CHANNELS WITH 19mm (3/4) HEIGHT
 CANAL HORIZONTAL PARA TRAPEZCIO / HORIZONTAL CHANNEL FOR SUPPORT

HORIZONTAL CHANNEL FOR TRAPEZOID SUPPORT

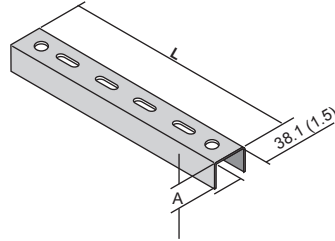

PARA ALTURA A DE 19 (3/4) FOR 19 (3/4) HEIGHT	NUMERO DE CATALOGO PARA ALTURA A DE 38.1 (1) FOR 38.1 (1) HEIGHT	CATALOG NUMBER ANCHO DE CHAROLA TRAY WIDTH	L
CPPV-04	CPV-04	101.6 (4)	195 (7.69)
CPPV-06	CPV-06	152.4 (6)	246 (9.69)
CPPV-09	CPV-09	228.9 (9)	322 (12.69)
CPPV-12	CPV-12	304.8 (12)	398 (15.69)
CPPV-16	CPV-16	406.4 (16)	500 (19.69)
CPPV-18	CPV-18	457.2 (18)	551 (21.69)
CPPV-20	CPV-20	508.0 (20)	602 (23.69)
CPPV-24	CPV-24	609.6 (24)	703 (27.69)
CPPV-30	CPV-30	762.0 (30)	856 (33.69)
CPPV-36	CPV-36	914.4 (36)	1008 (39.69)

NO INCLUYE TORNILLERIA, VARILLAS, CLIPS "U" NI SISTEMAS DE FIJACION
 HARDWARE, "U" CLAMP, THREADED RODS OR ANCHORING SYSTEM ARE NOT INCLUDED

CLIP "U"

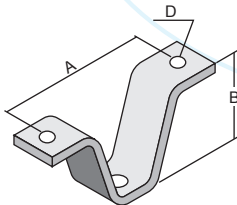

CU-38-GI

MATERIAL Y ACABADO VER PAGINA 34 / MATERIAL & FINISHES SEE PAGE 34
 TAMAÑO NOMINAL DE VARILLA ROSCADA / THREADED ROAD SIZE
 CLIP "U" / FORM "U" CLAMP

N° DE CATALOGO CATALOG NUMBER	TAMAÑO DE VARILLA ROAD SIZE	A	B	D
CU-38	9.5 (3/8)	110 (4.32)	57 (2.24)	9.5 (3/8)
CU-12	12.7 (1/2)	133 (5.23)	63 (2.48)	14.3 (9/16)
CU-58	15.9 (5/8)	143 (5.62)	67 (2.63)	14.3 (9/16)

NO INCLUYE TORNILLERIA, VARILLAS, NI SISTEMAS DE FIJACION
 HARDWARE, THREADED RODS OR ANCHORING SYSTEM ARE NOT INCLUDED

FORM "U" CLAMP

VARILLA ROSCADA

VR-38-3.0GI

MATERIAL Y ACABADO (VER PAGINA 34, EXCEPTO GI)
 MATERIAL & FINISHES (SEE PAGE 34 EXCEPT GI)
 LONGITUD EN METROS (DISPONIBLE EN 1.0, 2.0 Y 3.0 METROS)
 LENGHT IN METERS (AVAILABLE IN 1.0, 2.0 Y 3.0 METERS)
 TAMAÑO NOMINAL SIZE
 VARILLA ROSCADA THREADED ROD

N° DE CATALOGO CATALOG NUMBER	TAMAÑO NOMINAL SIZE
VR-38	9.5 (3/8)
VR-12	12.7 (1/2)
VR-58	15.9 (5/8)

THREADED ROD

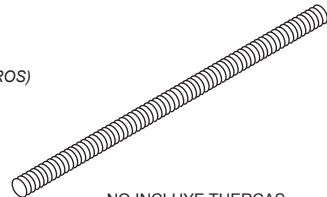

NO INCLUYE TUERCAS
 NUTS NOT INCLUDED

TODAS LAS DIMENSIONES EN mm (Pulg) / ALL DIMENSIONS ARE IN mm (Inch)

PUEDO SER SUJETO A MODIFICACION SIN PREVIO AVISO / MAY BE SUBJECT TO MODIFICATION WITHOUT NOTICE

SOPORTES COLGANTES A LATERAL

SIDE RAIL HANGING SUPPORT

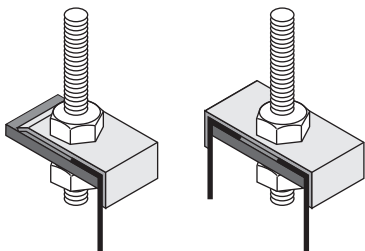

SENCILLO SINGLE

DOBLE DOUBLE

SDH-38-GI

MATERIAL Y ACABADO (VER PAGINA 34)
 MATERIAL & FINISHES (SEE PAGE 34)
 TAMAÑO NOMINAL DE VARILLA ROSCADA
 THREADED ROD SIZE
 TIPO (SENCILLO O DOBLE)
 TYPE SUPPORT (SINGLE OR DOUBLE)
 COLGADOR A LATERAL SIDE RAIL HANGER

N° DE CATALOGO CATALOG NUMBER		TAMAÑO DE VARILLA ROAD SIZE
SENCILLO SINGLE	DOBLE DOUBLE	
SSH-38	SDH-38	9.5 (3/8)
SSH-12	SDH-12	12.7 (1/2)
SSH-58	SDH-58	15.9 (5/8)

NO INCLUYE TUERCAS NI VARILLA
 NUTS OR THREADED RODS ARE NOT INCLUDED

SOPORTE VERTICAL

VERTICAL SUPPORT

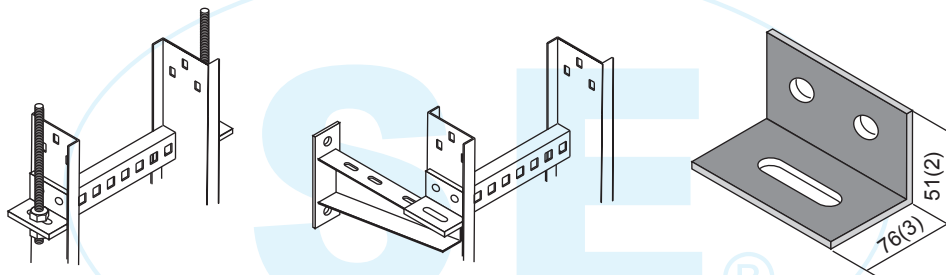

SV-1GI

MATERIAL Y ACABADO (VER PAGINA 34)
 MATERIAL & FINISHES (SEE PAGE 34)
 SUBFIJO P/PERALTE (VER PAG 9)
 RAIL HEIGHT SUFFIX (SEE PAGE 9)
 SOPORTE VERTICAL / VERTICAL SUPPORT

PARA USARSE CON VARILLA ROSCADA
 DE 12.7 (1/2) NO INCLUIDA
 FOR USE WITH THREADED
 12.7 (1/2) NOT INCLUDED

SOPORTE PARA PISO

FLOOR SUPPORT

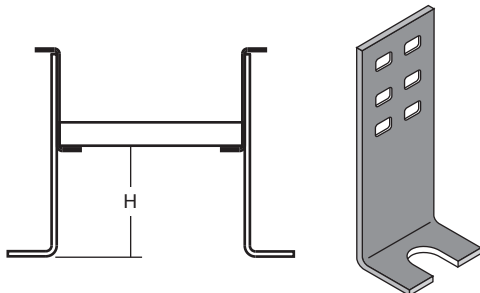

SP-30-1GI

MATERIAL Y ACABADO (VER PAGINA 34)
 MATERIAL & FINISHES (SEE PAGE 34)
 SUBFIJO P/PERALTE (VER PAG 9)
 RAIL HEIGHT SUFFIX (SEE PAGE 9)
 ALTURA H / HEIGHT H
 SOPORTE PARA PISO / FLOOR SUPPORT

TODAS LAS DIMENSIONES EN mm (Pulg) / ALL DIMENSIONS ARE IN mm (Inch)
 PUEDE SER SUJETO A MODIFICACION SIN PREVIO AVISO / MAY BE SUBJECT TO MODIFICATION WITHOUT NOTICE

CLEMA PARA CHAROLA

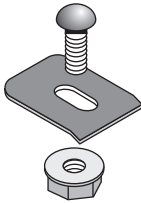

CLAMP-112-GI

MATERIAL Y ACABADO (VER PAGINA 34)
 MATERIAL & FINISHES (SEE PAGE 34)
 CLEMA PARA CHAROLA / HOLD-DOWN CLAMP

INCLUYE TORNILLERIA
 HARDWARE INCLUDED

HOLD-DOWN CLAMP

CLIPS ANGULARES

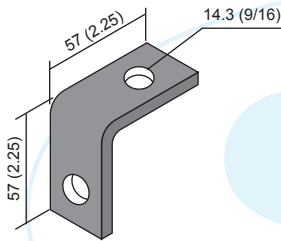

TIPO SENCILLO SINGLE TYPE
 N° DE CATALOGO CATALOG NUMBER **CAFC-234**

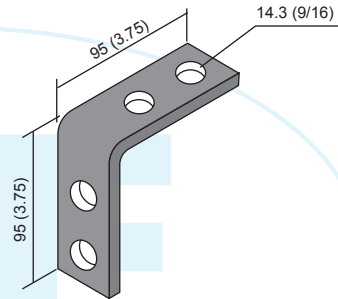

TIPO REFORZADO REINFORCED TYPE
 N° DE CATALOGO CATALOG NUMBER **CAFL-334**

CAFC-234-GI

MATERIAL Y ACABADO (VER PAGINA 85)
 MATERIAL & FINISHES (SEE PAGE 85)
 TIPO TYPE

ANGULAR CLAMP

COPE PARA VARILLA ROSCADA

CVR-38-GI

MATERIAL Y ACABADO (VER PAGINA 34, EXCEPTO GI)
 MATERIAL & FINISHES (SEE PAGE 34 EXCEPT GI)
 TAMAÑO NOMINAL / SIZE
 COPE PARA VARILLA ROSCADA / THREADED COUPLING

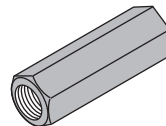

N° DE CATALOGO CATALOG NUMBER	TAMAÑO NOMINAL SIZE
CVR-38	9.5 (3/8)
CVR-12	12.7 (1/2)
CVR-58	15.9 (5/8)

THREADED COUPLING

TODOS LOS SISTEMAS DE APOYO MOSTRADOS EN ESTA SECCION DEBERAN SER COLOCADOS DE ACUERDO A LA NORMA NEMA VE-2
 ALL THE FRAMES SHOWN IN THIS SECTION SHOULD BE INSTALLED UNDER STANDARD NEMA VE 2

TODAS LAS DIMENSIONES EN mm (Pulg) / ALL DIMENSIONS ARE IN mm (Inch)
 PUEDE SER SUJETO A MODIFICACION SIN PREVIO AVISO / MAY BE SUBJECT TO MODIFICATION WITHOUT NOTICE

SECCION 1.5 SOPORTERIA PARA CABLES TIPO MARINO

SECTION 1.5 MARINE TYPE CABLE TRAY SYSTEM

SECCIONES

SECTIONS

PERALTE NOMINAL SIDE RAIL HEIGHT	SUBFIJO P/PERALTE RAIL HEIGHT SUFFIX	CLASE NEMA NEMA CLASS
35	35	6B
60	60	8B
85	85	8C
110	110	12B



TRAMO RECTO

STRAIGHT SECTION

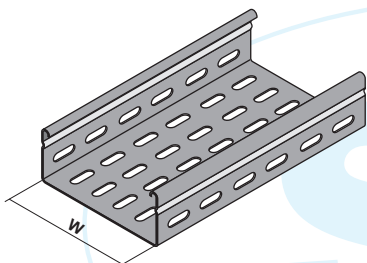

CHM-100-35GI

MATERIAL Y ACABADO MATERIAL & FINISH
 SUBFIJO P/PERALTE RAIL HEIGHT SUFFIX
 ANCHO WIDTH
 TIPO MARINO MARINE TYPE
 TRAMO RECTO STRAIGHT SECTION

LONGITUD ESTANDARD 3.000 m
 STANDARD LENGHT 3.000 m

PARA LONGITUDES DIFERENTES CONSULTE
 NUESTRO DEPARTAMENTO DE INGENIERIA

FOR LENGHT NOT SHOWED PLEASE CONTACT
 OUR TECHNICAL DEPARTMENT

INCLUYE 2 CONECTORES ARM Y TORNILLERIA
 TWO ARM CONNECTOR AND HARDWARE INCLUDED

NUMERO DE CATALOGO CATALOG NUMBER

ANCHO W WIDTH W	PERALTE SIDE RAIL HEIGHT			
	35	60	85	110
100	CHM-100-35	CHM-100-60	CHM-100-85	CHM-100-110
200	CHM-200-35	CHM-200-60	CHM-200-85	CHM-200-110
300	CHM-300-35	CHM-300-60	CHM-300-85	CHM-300-110
400		CHM-400-60	CHM-400-85	CHM-400-110
500		CHM-500-60	CHM-500-85	CHM-500-110
600		CHM-600-60	CHM-600-85	CHM-600-110

MATERIALES Y ACABADOS DISPONIBLES:

MATERIALS & FINISHES AVAILABLE :

A: ALUMINIO ALEACION AA-6063 ACABADO NATURAL

A: AA-6063 NATURAL FINISHED ALUMINUM

GI : ACERO AL CARBONO GALVANIZADO POR INMERSION
 EN CALIENTE SEGUN ASTM A 525

GI : HOT DIP GALVANIZED STEEL UNDER ASTM A 525

AI : ACERO INOXIDABLE ACABADO NATURAL

AI : NATURAL FINISHED STAINLESS STEEL

PARA MATERIALES Y ACABADOS NO INDICADOS CONSULTE NUESTRO DEPARTAMENTO DE INGENIERIA
 FOR MATERIALS AND FINISHES NOT SHOWED. PLEASE CONSULT OUT TECHNICAL DEPARTMENT

TODAS LAS DIMENSIONES EN mm ALL DIMENSIONS ARE IN mm
 PUEDE SER SUJETO A MODIFICACION SIN PREVIO AVISO MAY BE SUBJECT TO MODIFICATION WITHOUT NOTICE

CURVAS HORIZONTALES A 90° Y 45°

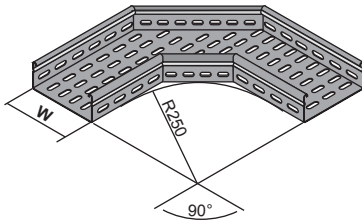

90° & 45° HORIZONTAL BEND

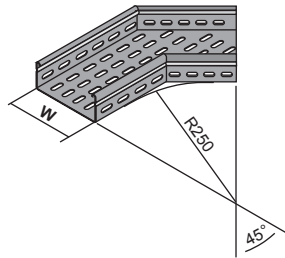

VHM-100R25090-35GI

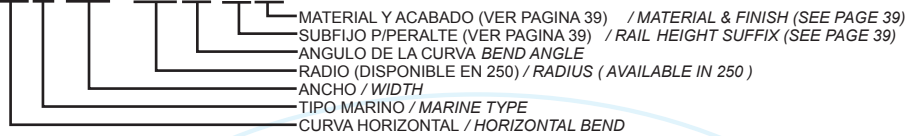

NUMERO DE CATALOGO CATALOG NUMBER

ANCHO W WIDTH W	ANGULO ANGLE	
	45°	90°
100	VHM-100R25045	VHM-100R25090
200	VHM-200R25045	VHM-200R25090
300	VHM-300R25045	VHM-300R25090
400	VHM-400R25045	VHM-400R25090
500	VHM-500R25045	VHM-500R25090
600	VHM-600R25045	VHM-600R25090

INCLUYE 2 CONECTORES ARM Y TORNILLERIA / TWO ARM CONNECTOR AND HARDWARE INCLUDED

“TEE” HORIZONTAL

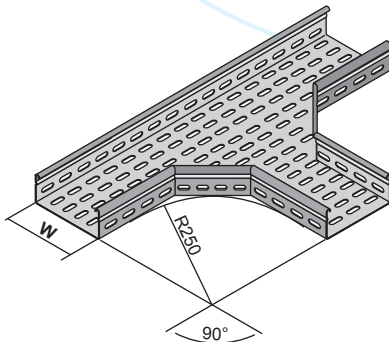

HORIZONTAL “TEE”

THM-100R250-35GI

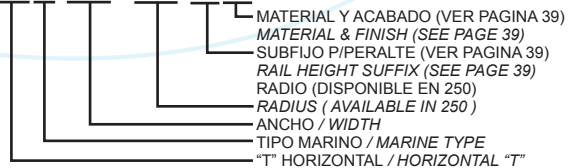

INCLUYE 2 CONECTORES ARM Y TORNILLERIA
TWO ARM CONNECTOR AND HARDWARE INCLUDED

NUMERO DE CATALOGO CATALOG NUMBER	ANCHO W WIDTH W
THM-100R250	100
THM-200R250	200
THM-300R250	300
THM-400R250	400
THM-500R250	500
THM-600R250	600

TODAS LAS DIMENSIONES EN mm / ALL DIMENSIONS ARE IN mm
PUEDEN SER SUJETOS A MODIFICACION SIN PREVIO AVISO / MAY BE SUBJECT TO MODIFICATION WITHOUT NOTICE

"EQUIS" HORIZONTAL

HORIZONTAL CROSS

XHM-100R250-35GI

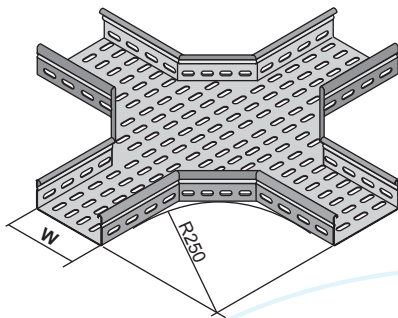

- MATERIAL Y ACABADO (VER PAGINA 39)
- MATERIAL & FINISH (SEE PAGE 39)
- SUBFIJO P/PERALTE (VER PAGINA 39)
- RAIL HEIGHT SUFFIX (SEE PAGE 39)
- RADIO (DISPONIBLE EN 250)
- RADIUS (AVAILABLE IN 250)
- ANCHO / WIDTH
- TIPO MARINO / MARINE TYPE
- EQUIS HORIZONTAL / HORIZONTAL CROSS

INCLUYE 2 CONECTORES ARM Y TORNILLERIA
TWO ARM CONNECTOR AND HARDWARE INCLUDED

NUMERO DE CATALOGO CATALOG NUMBER	ANCHO W WIDTH W
XHM-100R250	100
XHM-200R250	200
XHM-300R250	300
XHM-400R250	400
XHM-500R250	500
XHM-600R250	600

REDUCCIONES

REDUCER

RLM-300200-35GI

- MATERIAL Y ACABADO (VER PAGINA 39)
- MATERIAL & FINISH (SEE PAGE 39)
- SUBFIJO P/PERALTE (VER PAGINA 39)
- RAIL HEIGHT SUFFIX (SEE PAGE 39)
- ANCHO MENOR / SMALLEST WIDTH
- ANCHO MAYOR / LARGEST WIDTH
- TIPO MARINO / MARINE TYPE
- REDUCCION / REDUCER

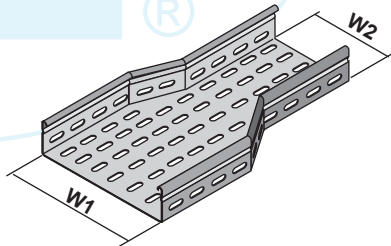

INCLUYE 2 CONECTORES ARM Y TORNILLERIA
TWO ARM CONNECTOR AND HARDWARE INCLUDED

NUMERO DE CATALOGO CATALOG NUMBER

ANCHO W1 WIDTH W1	ANCHO MENOR W2 SMALLEST WIDTH W2				
	100	200	300	400	500
200	RLM-200100				
300	RLM-300100	RLM-300200			
400	RLM-400100	RLM-400200	RLM-400300		
500	RLM-500100	RLM-500200	RLM-500300	RLM-500400	
600	RLM-600100	RLM-600200	RLM-600300	RLM-600400	RLM-600500

TODAS LAS DIMENSIONES EN mm / ALL DIMENSIONS ARE IN mm
PUEDE SER SUJETO A MODIFICACION SIN PREVIO AVISO / MAY BE SUBJECT TO MODIFICATION WITHOUT NOTICE

CURVA VERTICAL AJUSTABLE

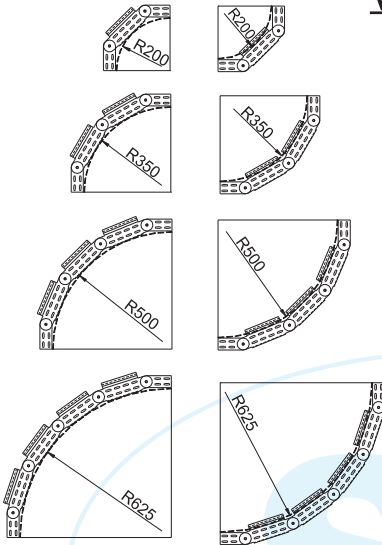

VAM-100R200-35GI

VERTICAL ADJUSTABLE BEND

- MATERIAL Y ACABADO (VER PAGINA 39)
- MATERIAL & FINISH (SEE PAGE 39)
- SUBFIJO P/PERALTE (VER PAGINA 39)
- RAIL HEIGHT SUFFIX (SEE PAGE 39)
- RADIO / RADIUS
- ANCHO / WIDTH
- TIPO MARINO / MARINE TYPE
- CURVA VERTICAL AJUSTABLE
- VERTICAL ADJUSTABLE BEND

CANTIDAD DE ELEMENTOS AJUSTABLES
ADJUSTABLE ELEMENT Q16

RADIO RADIUS	ELEMENTOS AJUSTABLES ADJUSTABLE ELEMENTS
200	1
350	2
500	3
625	4

ANCHO W WIDTH W	No DE CATALOGO		CATALOG NUMBER	
	RADIO		RADIUS	
	200	350	500	625
100	VAM-100R200	VAM-100R350	VAM-100R500	VAM-100R625
200	VAM-200R200	VAM-200R350	VAM-200R500	VAM-200R625
300	VAM-300R200	VAM-300R350	VAM-300R500	VAM-300R625
400	VAM-400R200	VAM-400R350	VAM-400R500	VAM-400R625
500	VAM-500R200	VAM-500R350	VAM-500R500	VAM-500R625
600	VAM-600R200	VAM-600R350	VAM-600R500	VAM-600R625

INCLUYE 4 CONECTORES EACM CON TORNILLERIA
FOUR EACM CONNECTORS AND HARDWARE INCLUDED

ELEMENTO VERTICAL AJUSTABLE

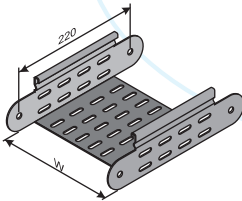

VERTICAL ADJUSTABLE ELEMENT

VAM-10035GI

- MATERIAL Y ACABADO (VER PAGINA 39)
- MATERIAL & FINISH (SEE PAGE 39)
- SUBFIJO P/PERALTE (VER PAGINA 39)
- RAIL HEIGHT SUFFIX (SEE PAGE 39)
- ANCHO / WIDTH
- TIPO MARINO / MARINE TYPE
- CURVA VERTICAL AJUSTABLE
- VERTICAL ADJUSTABLE BEND

No DE CATALOGO CATALOG NUMBER	ANCHO W WIDTH W
VAM-100	100
VAM-200	200
VAM-300	300
VAM-400	400
VAM-500	500
VAM-600	600

NO INCLUYE CONECTORES NI TORNILLERIA
CONNECTORS OR HARDWARE ARE NOT INCLUDED

CONECTOR VERTICAL AJUSTABLE

EACM-35GI

- MATERIAL Y ACABADO (VER PAGINA 39)
- MATERIAL & FINISH (SEE PAGE 39)
- SUBFIJO P/PERALTE (VER PAGINA 39)
- RAIL HEIGHT SUFFIX (SEE PAGE 39)
- TIPO MARINO / MARINE TYPE
- CONECTOR PARA CURVA VERTICAL AJUSTABLE
- CONNECTOR FOR VERTICAL ADJUSTABLE BEND

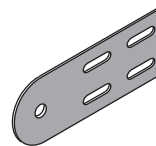

INCLUYE TORNILLERIA / HARDWARE INCLUDED

TODAS LAS DIMENSIONES EN mm / ALL DIMENSIONS ARE IN mm
 PUEDE SER SUJETO A MODIFICACION SIN PREVIO AVISO / MAY BE SUBJECT TO MODIFICATION WITHOUT NOTICE

TAPAS

COVERS

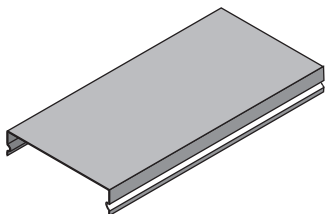

TCV CHM-100-GI

MATERIAL Y ACABADO (VER PAGINA 39)
 MATERIAL & FINISH (SEE PAGE 39)
 No DE CATALOGO DEL PRODUCTO A CUBRIR
 PRODUCT TO COVER CATALOG NUMBER
 TAPA CON CEJA Y VENA
 COVER WITH STREAK AND FLANGED

NO REQUIERE CLIPS O TORNILLERIA
 CLAMPS OR HARDWARE IS NOT REQUIRED

CONECTORES

CONNECTORS

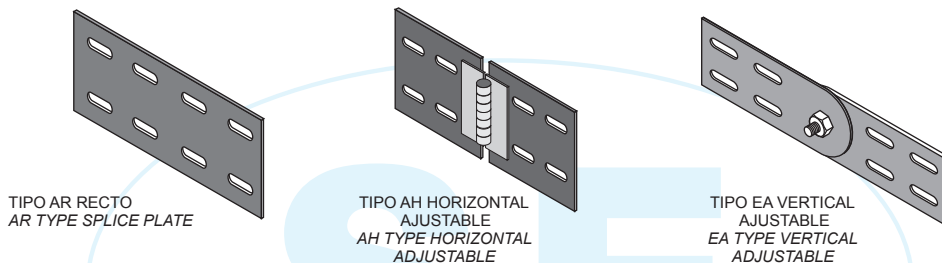

TIPO AR RECTO
 AR TYPE SPLICE PLATE

TIPO AH HORIZONTAL
 AJUSTABLE
 AH TYPE HORIZONTAL
 ADJUSTABLE

TIPO EA VERTICAL
 AJUSTABLE
 EA TYPE VERTICAL
 ADJUSTABLE

ARM-35GI

MATERIAL Y ACABADO (VER PAGINA 39) / MATERIAL & FINISH (SEE PAGE 39)
 SUBFIJO P/PERALTE (VER PAGINA 39) / RAIL HEIGHT SUFFIX (SEE PAGE 39)
 TIPO MARINO MARINE TYPE
 CONECTOR TIPO / CONNECTOR TYPE

INCLUYE TORNILLERIA / HARDWARE INCLUDED

TAPA TERMINAL

BLIND END

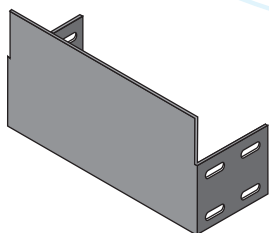

PTRM-100-35GI

MATERIAL Y ACABADO (VER PAGINA 39)
 MATERIAL & FINISH (SEE PAGE 39)
 SUBFIJO P/PERALTE (VER PAGINA 39)
 RAIL HEIGHT SUFFIX (SEE PAGE 39)
 ANCHO / WIDTH
 TIPO MARINO / MARINE TYPE
 TAPA TERMINAL / BLIND END

No DE CATALOGO CATALOG NUMBER	ANCHO W WIDTH W
PTRM-100	100
PTRM-200	200
PTRM-300	300
PTRM-400	400
PTRM-500	500
PTRM-600	600

INCLUYE TORNILLERIA / HARDWARE INCLUDED

TODAS LAS DIMENSIONES EN mm / ALL DIMENSIONS ARE IN mm
 PUEDE SER SUJETO A MODIFICACION SIN PREVIO AVISO / MAY BE SUBJECT TO MODIFICATION WITHOUT NOTICE

SECCION 1.6 SOPORTERIA PARA CABLES TIPO MALLA

SECTION 1.6 CABLE TRAY SYSTEM WIRE MESH TYPE

Los sistemas de soportería para cables tipo malla fabricados por SOPORTES ELECTRICOS son desarrollados pensados para instalaciones de control, señalización e iluminación, donde se requieren cargas bajas, como son : tiendas de autoservicio, cuartos de máquinas, cuartos de control, edificios inteligentes, cableados estructurados y toda aplicación donde no se presenten riesgos de daños a cables.

Los sistemas de soportería para cables tipo malla de SOPORTES ELECTRICOS están fabricados de filamentos de acero longitudinales, de alta resistencia a la tensión, estos filamentos son unidos entre sí mediante filamentos transversales que le dan cohesión y rigidez al sistema.

Las charolas SOPORTES ELECTRICOS no precisan ningún elemento adicional para el ensamblaje se montan simplemente situando una bandeja sobre la anterior y ejerciendo presión.

La instalación de las bandejas para una canalización eléctrica NO debe efectuarse por debajo de otro tipo de canalizaciones, como las de agua, vapor o gas.

Para facilitar una correcta ventilación, se recomienda instalar las bandejas con una distancia mínima entre ellas de 250 mm

Se deben separar 20 mm de la pared las bandejas que se coloquen sobre soportes, para permitir ventilación óptima de los cables

Al ser ventilados los cables, permiten una mayor capacidad de conducción.

Permiten la acometida de cables tanto por la parte superior como inferior y lateral.

Son de fácil instalación y las modificaciones, así como derivaciones y curvas pueden realizarse en campo con herramientas mínimas.

El sistema es muchísimo más ligero que los sistemas rígidos ahorrando en anclaje, estructuración y sistemas de apoyo.

Por esta y muchas razones más :

!!!!!!EN SISTEMAS DE SOPORTERIA TIPO MALLA SEGUIMOS SIENDO LA MEJOR OPCION!!!!!!

The SOPORTES ELECTRICOS wire mesh type cable tray systems was designed thinking in control, signal and lighting electrical instalation where low loads are required, instalations like stores, control rooms, machines rooms, inteligent building, structural cabling and all applications where don't appere risk of damage to cables.

The SOPORTES ELECTRICOS wire mesh type cable tray systems are made of hight strenght resistance steel long filaments, those filaments are joint between each other for transversal wires thas give cohetion and strongtness to the system.

The BASORFIL BF2R trays require no additional element for assembly, they are simply placed putting together the trays by pressuring.

The installation of the electrical trays must not be made together with water, steam or gas installations.

For a proper ventilation, it is recomended to install the trays separated by a minimum distance of 10 inches (250 mm).

The trays that are placed on supports must be separated 20 mm from the wall, to provide ventilation to the cables.

All the systes is ventes so you have more electrical ampacity

HIGHT TEMPERATURE RESISTANCE.- The SOPORTES ELECTRICOS fiber glass cable tray systems has a grat temperature resistance and can be used in any enviroment whith a good profile.

The system is able to drop out cable for all positions top butoom, and sides.

The instalation and assambly are very easy and all the fittings are made in field with a minimum tools.

The system is lighter than the rigid systems so you have cheaper structural and support system.

!!!!!!IN CABLE TRAY SYSTEMS WE ARE, AGAIN, THE BEST CHOICE!!!!!!

SECCIONES

PERALTE NOMINAL HEIGHT SIZE	SUBFIJO P/PERALTE HEIGHT SUFFIX	CLASE NEMA NEMA CLASS
35	35	5AA
65	65	6BB
105	105	8A

SECTIONS

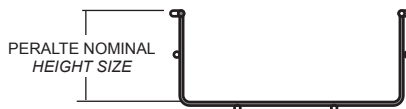

TRAMO RECTO

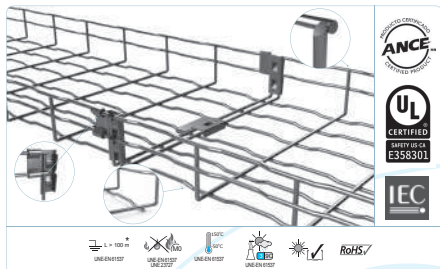

STRAIGHT SECTION

CL-10035GI

MATERIAL Y ACABADO MATERIAL & FINISH
SUBFIJO P/PERALTE HEIGHT SUFFIX
ANCHO WIDTH
TRAMO RECTO / STRAIGHT SECTION

LONGITUD ESTANDARD 3.000 m
STANDARD LENGHT 3.000 m

NUMERO DE CATALOGO CATALOG NUMBER

ANCHO W WIDTH W	PERALTE HEIGHT		
	35	65	105
60		CL-6065	
100	CL-10035	CL-10065	
150		CL-15065	
200	CL-20035	CL-20065	CL-200105
300	CL-30035	CL-30065	CL-300105
400		CL-40065	CL-400105
500		CL-50065	CL-500105
600		CL-60065	CL-600105

Ahora, SOPORTES ELECTRICOS introduce al mercado la nueva charola "enchufable" con un diseño ergonómico y novedoso que permite una conexión ultra-rápida mediante un sistema de conectores integrados sin costo adicional

CONECTOR INCLUIDO SOLO PARA ACABADO GE.
LOS DEMAS ACABADOS CONSIDERAR CONECTORES PARA COMPRA

CONNECTOR INCLUDED ONLY FOR FINISHING GE.
THE OTHER FINISHES CONSIDER CONNECTORS FOR PURCHASE

LOS ACCESORIOS SE FABRICAN A PARTIR DE TRAMOS RECTOS EN CAMPO, POR TANTO NO SE OFRECEN EN ESTE CATALOGO PARA LA ELABORACION DE ACCESORIOS Y DERIVACIONES VER EL MANUAL DE ELABORACION CORRESPONDIENTE EDITADO POR SOPORTES ELECTRICOS.

THE FITTINGS ARE NOT SHOWN IN THIS CATALOG BECAUSE THEY SHOULD BE MADE IN FIELD USING STRAIGHT SECTIONS. FOR MAKE FITTING PLEASE CONSULT THE CABLE TRAY WIRE MESH HANDBOOK PUBLISHED BY SOPORTES ELECTRICOS.

CONECTORES Y TORNILLERIA NO SE INCLUYEN, ESTOS DEBERAN SER SOLICITADOS POR SEPARADO DE ACUERDO A LOS ACCESORIOS QUE SERAN FABRICADOS EN CAMPO.

NITHER CONNECTORS OR HARDWARE ARE NOT INCLUDE, THEY SHOUD BE REQUESTED ACCORDING WITH THE FITTING THAT YOU WILL MAKE IN FIELD

MATERIALES Y ACABADOS DISPONIBLES:

GI : ACERO AL CARBONO GALVANIZADO POR INMERSION EN CALIENTE SEGUN ASTM A 123 (CONECTOR NO INCLUIDO)

GE : ACERO AL CARBONO GALVANIZADO ELECTROLITICO SEGUN ASTM B 633 (CONECTOR INCLUIDO)

T : ACERO AL CARBONO TROPICALIZADO (CONECTOR NO INCLUIDO)

PVC : ACERO AL CARBONO RECUBIERTO CON PVC SEGUN NEMA RN 1 (CONECTOR NO INCLUIDO)

AI : ACERO INOXIDABLE ACABADO NATURAL (CONECTOR NO INCLUIDO)

PARA MATERIALES Y ACABADOS NO INDICADOS CONSULTE NUESTRO DEPARTAMENTO DE INGENIERIA FOR MATERIALS AND FINISHES NOT SHOWN. PLEASE CONSULT OUT TECHNICAL DEPARTMENT

TODAS LAS DIMENSIONES EN mm / ALL DIMENSIONS ARE IN mm

PUEDER SER SUJETO A MODIFICACION SIN PREVIO AVISO / MAY BE SUBJECT TO MODIFICATION WITHOUT NOTICE

MATERIALS & FINISHES AVAILABLE :

GI : HOT DIP GALVANIZED STEEL UNDER ASTM A 123 (CONNECTOR NOT INCLUDED)

GE : ELECTROGALVANIZED STEEL UNDER ASTM B 633 (CONNECTOR INCLUDED)

T : CHROMIUM-ZINC COATED STEEL (CONNECTOR NOT INCLUDED)

PVC : PVC COATED STEEL UNDER NEMA RN 1 (CONNECTOR NOT INCLUDED)

AI : NATURAL FINISHED STAINLESS STEEL (CONNECTOR NOT INCLUDED)

CONECTORES UNIVERSALES

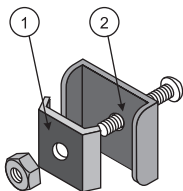

CUCL-01

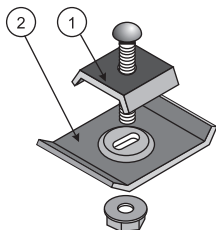

CUCL-02

STANDARD CONNECTORS

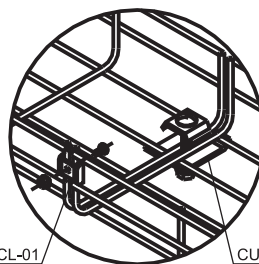

CUCL-01

CUCL-02

CADA CONECTOR INCLUYE
INCLUDING IN EACH CONNECTOR

No DE CATALOGO CATALOG NUMBER	PIEZA 1 DITTO 1	PIEZA 2 DITTO 2
CUCL-01	CE-25	CE-25
CUCL-02	CE-30	CE-40

LOS CONECTORES PUEDEN SER SOLICITADOS POR JUEGO (CUCL)
O POR PARTES (CE)

THE CONNECTOR CAN BE REQUESTED IN KIT (CUCL) OR IN PARTS (CE)

AMBOS CONECTORES INCLUYEN TORNILLERIA CUANDO SON SOLICITADOS EN JUEGO
HARDWARE INCLUDED IN BOTH CONNECTORS WHEN THEY ARE REQUESTED IN KIT

AL FINAL DEL NUMERO DE CATALOGO INDICAR MATERIAL Y ACABADO (VER PAGINA 45)
AT THE END OF THE CATALOG NUMBER ADD MATERIAL AND FINISH (SEE PAGE 45)

SOPORTE SIMPLE

SUPPORT SIMPLE

No DE CATALOGO : **SLCL**
CAT NUMBER :



MINI SOPORTE UNIVERSAL CAJAS

MINI UNIVERSAL BOX SUPPORT

No DE CATALOGO : **MSUCL-GE**
CAT NUMBER :



SOPORTE UNIVERSAL CAJAS

UNIVERSAL BOX SUPPORT

No DE CATALOGO : **SUCL-GE**
CAT NUMBER :



CONECTOR ANGULAR

No DE CATALOGO : **AT 90**
CAT NUMBER :

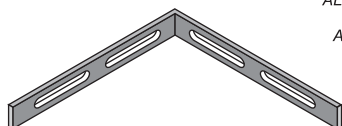

NO INCLUYE CONECTORES CE NI TORNILLERIA
HARDWARE OR CE CONNECTORS ARE NOT INCLUDED

AL FINAL DEL NUMERO DE CATALOGO INDICAR
MATERIAL Y ACABADO (VER PAGINA 45)
AT THE END OF THE CATALOG NUMBER ADD
MATERIAL AND FINISH (SEE PAGE 45)

ANGLE CONNECTOR

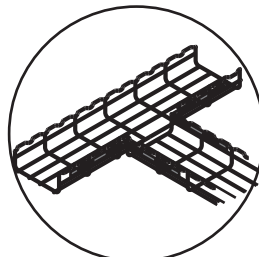

TODAS LAS DIMENSIONES EN mm / ALL DIMENSIONS ARE IN mm
PUEDEN SER SUJETO A MODIFICACION SIN PREVIO AVISO / MAY BE SUBJECT TO MODIFICATION WITHOUT NOTICE

CONECTORES RECTOS

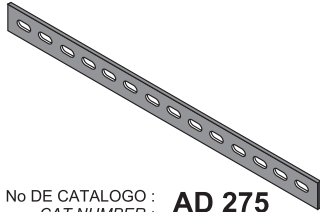

No DE CATALOGO : **AD 275**
CAT NUMBER :



No DE CATALOGO : **AD 75**
CAT NUMBER :

LONG SPLICE PLATE

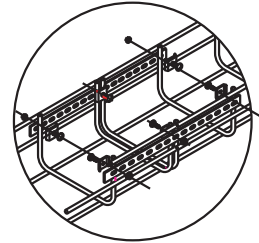

NO INCLUYE CONECTORES CE NI TORNILLERIA / *HARDWARE OR CE CONNECTORS ARE NOT INCLUDED*
AL FINAL DEL NUMERO DE CATALOGO INDICAR MATERIAL Y ACABADO (VER PAGINA 45)
AT THE END OF THE CATALOG NUMBER ADD MATERIAL AND FINISH (SEE PAGE 45)

CONECTORES ANGULAR CORTO

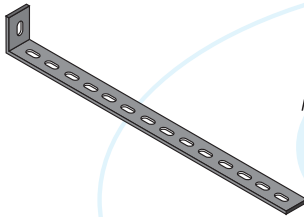

No DE CATALOGO : **AD 250/90**
CAT NUMBER :

NO INCLUYE CONECTORES CE NI TORNILLERIA
HARDWARE OR CE CONNECTORS ARE NOT INCLUDED

AL FINAL DEL NUMERO DE CATALOGO INDICAR
MATERIAL Y ACABADO (VER PAGINA 45)
AT THE END OF THE CATALOG NUMBER ADD
MATERIAL AND FINISH (SEE PAGE 45)

SMALL ANGULAR CONNECTOR

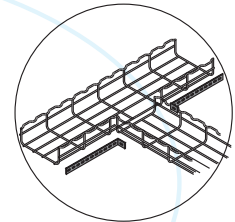

CONECTOR RAPIDO

FAST CONNECTOR

SUSPENSION CENTRAL

CENTRAL SUSPENSION

No DE CATALOGO : **ADRN**
CAT NUMBER :



AL FINAL DEL NUMERO DE CATALOGO INDICAR
MATERIAL Y ACABADO (VER PAGINA 45)
AT THE END OF THE CATALOG NUMBER ADD
MATERIAL AND FINISH (SEE PAGE 45)

No DE CATALOGO : **SCCL-01GE**
CAT NUMBER :



ABRAZADERA PARA TUBO CONDUIT A CHAROLA MALLA

A CONDUIT PIPE CLAMP MESH TRAY

SALIDA A TUBO

OUTPUT TUBE

No DE CATALOGO : **ACTMCL-GE**
CAT NUMBER :



No DE CATALOGO : **STCL-01GE**
CAT NUMBER :



TODAS LAS DIMENSIONES EN mm / *ALL DIMENSIONS ARE IN mm*
PUEDE SER SUJETO A MODIFICACION SIN PREVIO AVISO / *MAY BE SUBJECT TO MODIFICATION WITHOUT NOTICE*

CLIP COLGANTE

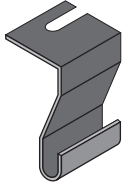

No DE CATALOGO : **AS**
CAT NUMBER :

NO INCLUYE VARILLA / ROD NOT INCLUDED

AL FINAL DEL NUMERO DE CATALOGO INDICAR MATERIAL Y ACABADO (VER PAGINA 45)
AT THE END OF THE CATALOG NUMBER ADD MATERIAL AND FINISH (SEE PAGE 45)

HANGER CLAMP

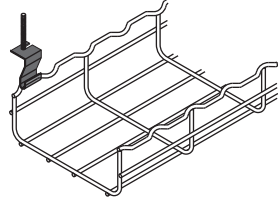

SOPORTE COLGANTE

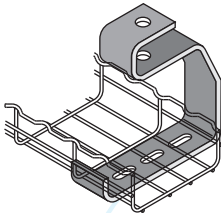

SCCL-100GI

MATERIAL Y ACABADO (VER PAGINA 45)
MATERIAL & FINISH (SEE PAGE 45)
ANCHO / WIDTH
COLGADOR / HANGER

HANGER SUPPORT

ANCHO DE CHAROLA TRAY WIDTH	NUMERO DE CATALOGO CATALOG NUMBER
60	SCCL-60
100	SCCL-100
150	SCCL-150
200	SCCL-200
300	SCCL-300
400	SCCL-400
500	SCCL-500
600	SCCL-600

MENSULA PARA PARED

ANCHO DE CHAROLA TRAY WIDTH	NUMERO DE CATALOGO CATALOG NUMBER
60	MPP-04
100	MPP-04
150	MPP-06
200	MPP-06
300	MPP-12
400	MPP-16
500	MPP-20
600	MPP-24

MPP-04-GI

MATERIAL Y ACABADO (VER PAGINA 45)
MATERIAL & FINISH (SEE PAGE 45)
ANCHO / WIDTH
MENSULA PARA CHAROLA DE MALLA
WIRE MESH TRAY BRACKET

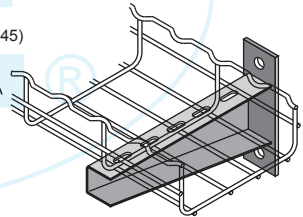

WALL CANTILEVER BRACKET

CANAL HORIZONTAL PARA TRAPEZIO

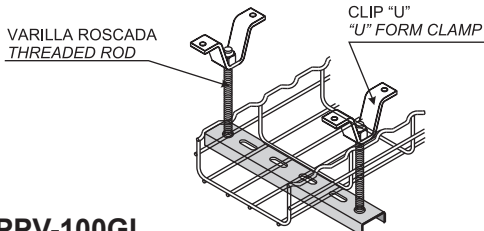

HORIZONTAL CHANNEL FOR TRAPEZE SUPPORT

ANCHO DE CHAROLA TRAY WIDTH	NUMERO DE CATALOGO CATALOG NUMBER
60	CPPV-04
100	CPPV-04
150	CPPV-06
200	CPPV-06
300	CPPV-12
400	CPPV-16
500	CPPV-20
600	CPPV-24

CPPV-100GI

MATERIAL Y ACABADO (VER PAGINA 45) / MATERIAL & FINISH (SEE PAGE 45)
ANCHO WIDTH
CANAL HORIZONTAL CHAROLA DE MALLA / WIRE MESH TRAY HORIZONTAL CHANNEL

NO INCLUYE TORNILLERIA, VARILLAS, CLIPS "U" NI SISTEMAS DE FIJACION
HARDWARE, "U" CLAMP, THREADED RODS OR ANCHORING SYSTEM ARE NOT INCLUDED

TODAS LAS DIMENSIONES EN mm / ALL DIMENSIONS ARE IN mm
PUEDE SER SUJETO A MODIFICACION SIN PREVIO AVISO / MAY BE SUBJECT TO MODIFICATION WITHOUT NOTICE

CANAL UNIVERSAL

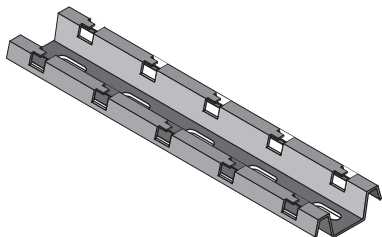

UNIVERSAL CHANNEL

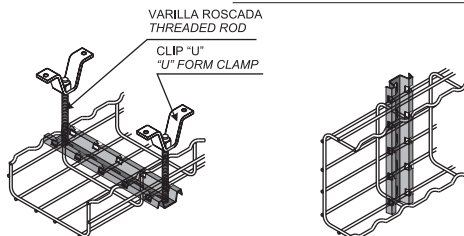

UCSN-500GI



MATERIAL Y ACABADO (VER PAGINA 45)
 MATERIAL & FINISH (SEE PAGE 45)
 LONGITUD LENGHT
 CANAL UNIVERSAL / UNIVERSAL CHANNEL

NO INCLUYE TORNILLERIA, VARILLAS, CLIPS "U"
 NI SISTEMAS DE FIJACION

HARDWARE, "U" CLAMP, THREADED RODS OR
 ANCHORING SYSTEM ARE NOT INCLUDED

LONGITUD DEL CANAL CHANNEL LENGHT	NUMERO DE CATALOGO CATALOG NUMBER
150	UCSN-150
200	UCSN-200
300	UCSN-300
400	UCSN-400
500	UCSN-500
600	UCSN-600
1000	UCSN-1000
2000	UCSN-2000
3000	UCSN-3000

MENSULA DE ENSAMBLE RAPIDO

NUMERO DE CATALOGO CATALOG NUMBER	LONGITUD L LENGHT L
MSNC-100	178
MSNC-150	228
MSNC-200	278
MSNC-300	378
MSNC-400	478

FAST ASSAMBLRY BRACKET

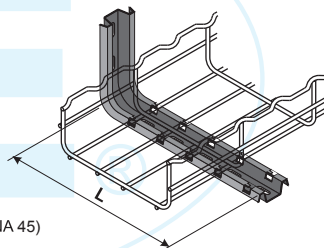

AL FINAL DEL NUMERO DE CATALOGO INDICAR MATERIAL Y ACABADO (VER PAGINA 45)
 AT THE END OF THE CATALOG NUMBER ADD MATERIAL AND FINISH (SEE PAGE 45)

SOPORTE PARA PISO

FLOOR SUPPORT

No DE CATALOGO : **SPCL**
 CAT NUMBER :

AL FINAL DEL NUMERO DE CATALOGO INDICAR
 MATERIAL Y ACABADO (VER PAGINA 45)
 AT THE END OF THE CATALOG NUMBER ADD
 MATERIAL AND FINISH (SEE PAGE 45)

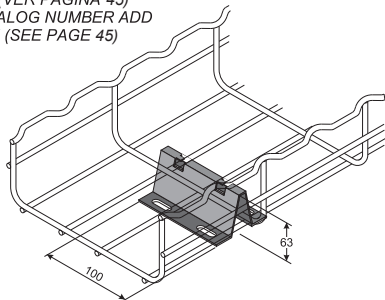

CLIP PARA UNICANAL

STRUT CONNECTION CLIP

No DE CATALOGO :
 CAT NUMBER :

CLIP-UNIGE



TODAS LAS DIMENSIONES EN mm / ALL DIMENSIONS ARE IN mm
 PUEDE SER SUJETO A MODIFICACION SIN PREVIO AVISO / MAY BE SUBJECT TO MODIFICATION WITHOUT NOTICE

TAPAS

PARA RETIRAR INTRODUCIR DESARMADOR
FOR DISASSEMBLY USE A SCREWDRIVER

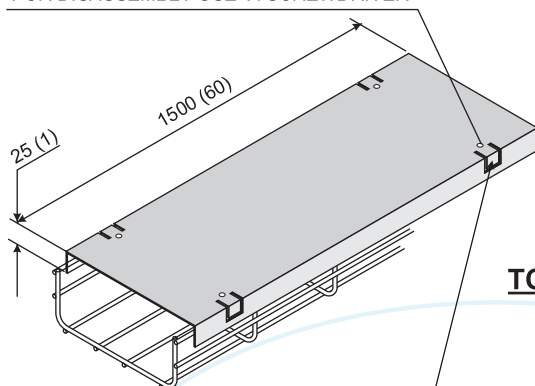

PARA SUJETAR DOBLAR ESTAS 4 PESTAÑAS
FOR ASSEMBLY BEND THE FOUR LIFT

DEBIDO A QUE EN CHAROLA TIPO MALLA LAS DERIVACIONES SE REALIZAN A PARTIR DE TRAMOS RECTOS,
LAS TAPAS PARA DERIVACIONES DEBERAN OBTENERSE A PARTIR DE TAPAS RECTAS.

FITTING COVERS SHOULD BE FIELD MADE USING STRAIGHT SECTION COVER.

BAJADA PARA CABLE

DROP-OUT

No DE CATALOGO : **BCL-10R50**
CAT NUMBER :

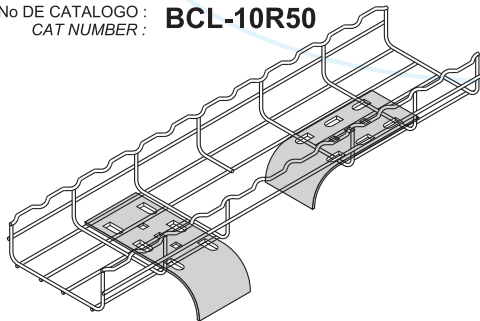

AL FINAL DEL NUMERO DE CATALOGO INDICAR
MATERIAL Y ACABADO (VER PAGINA 45)
AT THE END OF THE CATALOG NUMBER ADD
MATERIAL AND FINISH (SEE PAGE 45)

TODAS LAS DIMENSIONES EN mm / ALL DIMENSIONS ARE IN mm

PUEDA SER SUJETO A MODIFICACION SIN PREVIO AVISO / MAY BE SUBJECT TO MODIFICACION WITHOUT NOTICE

COVERS

N° DE CATALOGO CATALOG NUMBER	ANCHO DE LA CHAROLA TRAY WIDTH
TCCL-60	60
TCCL-100	100
TCCL-150	150
TCCL-200	200
TCCL-300	300
TCCL-400	400
TCCL-500	500
TCCL-600	600

TCCL-100GI

MATERIAL Y ACABADO (VER PAGINA 45)
MATERIAL & FINISH (SEE PAGE 45)
ANCHO WIDTH
TAPA CON CEJA PARA CHAROLA TIPO MALLA
FLANGED COVER FOR WIRE MESH TRAY

BARRERA SEPARADORA PARA CHAROLA TIPO MALLA

DIVIDER STRIP



No DE CATALOGO :
CAT NUMBER :

BSCL-35
BSCL-60
BSCL-100

CURVA HORIZONTAL

HORIZONTAL BENDS

LA FORMA DE HACER LAS CURVAS ES CORTANDO ZONAS DE LOS TRAMOS RECTOS, SE CORTA EL ALAMBRO EN SECCIONES COMO SE MUESTRA EN LA FIGURA DE TAL FORMA QUE LAS SECCIONES CORTADAS SE CIERREN Y SE UNAN; LOS DIAGRAMAS MOSTRADOS SON PARA DESARROLLAR CURVAS A 90°
 LOS ESPACIOS VACIOS INDICAN LA ZONA DONDE SE DEBE CORTAR Y REMOVER, UNA VEZ REMOVIDOS LA CONEXION SE REALIZARA CON LA CONEXION DE "CONECTOR UNIVERSAL" (CULC-01)

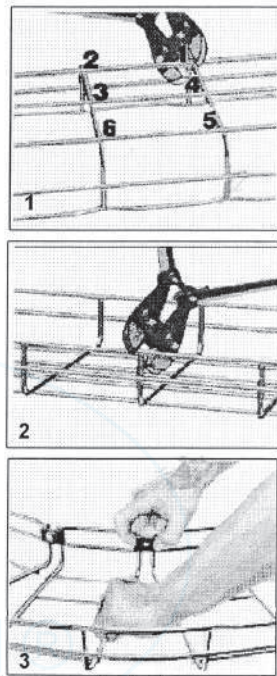

ANCHO	No. DE CONECTORES CULC-01	TIPO DE CORTE A REALIZAR
60 mm	2	
100 mm	3	
150 mm	4	
200 mm	5	
300 mm	6	
460 mm	9	
500 mm	11	
600 mm		

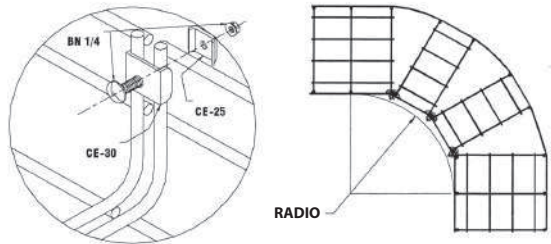

ANCHO	SECCIONES	
	CORTADAS	RADIO
100	3	10"
150	4	12"
200	5	14"
300	6	16"
400	9	24"
500	11	30"
600	11	30"

METODO DE UNION DE CHAROLAS

PRODUCTOS SOPORTES ELECTRICOS

LAS CURVAS VERTICALES DE MALLA PUEDEN FORMAR FACILMENTE CORTANDO LOS LATERALES DE LA CHAROLA EN SECCIONES LOCALIZADAS PREVIAMENTE, HASTA LOGRAR LA FORMA QUE SE REQUIERA, LA VARIEDAD DE FORMAS NO REQUIERE ELEMENTOS DE ENSAMBLE

EL FORMADO DE LOS RADIOS VERTICALES DEPENDE DEL CORTE DE SECCIONES PREVIAMENTE LOCALIZADAS

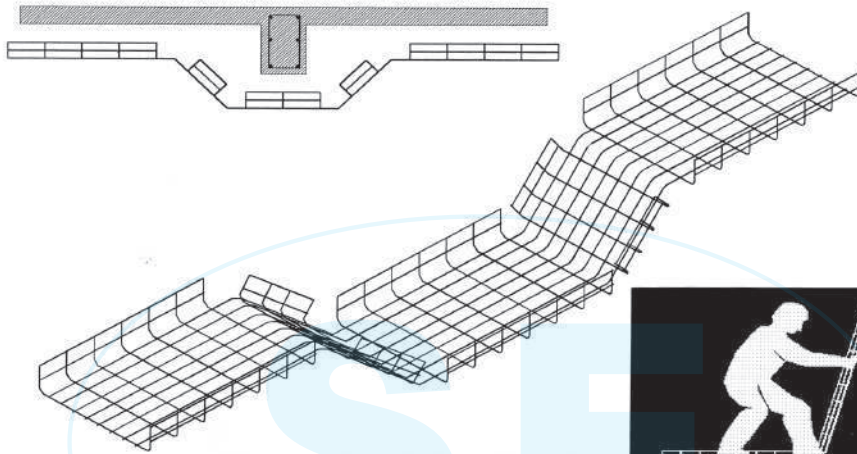

CURVA VERTICAL EXTERIOR

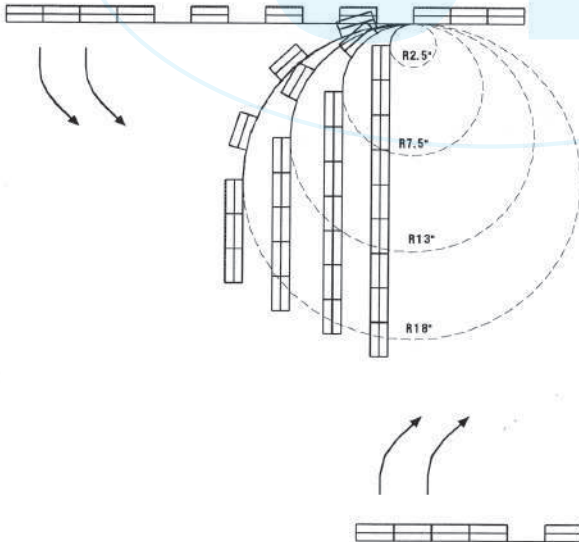

CURVA VERTICAL INTERIOR

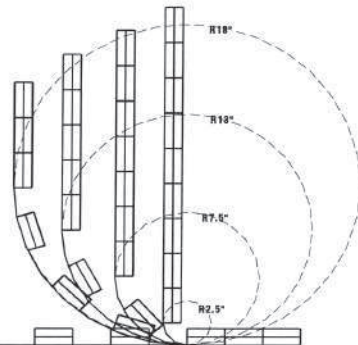

CURVAS HORIZONTALES DE RADIO CORTO

HORIZONTAL BENDS

LA FORMA DE HACER LAS CURVAS ES A TRAVES DE TRAMOS RECTOS, EL PROCEDIMIENTO ES CORTAR ALGUNAS ZONAS DE UN TRAMO RECTO Y CERRAR LA CURVA CON CONECTORES; LOS DIAGRAMAS MOSTRADOS SON PARA DESARROLLAR CURVAS A 90° LOS ESPACIOS VACIOS INDICAN LA ZONA DONDE SE DEBE CORTAR Y REMOVER.

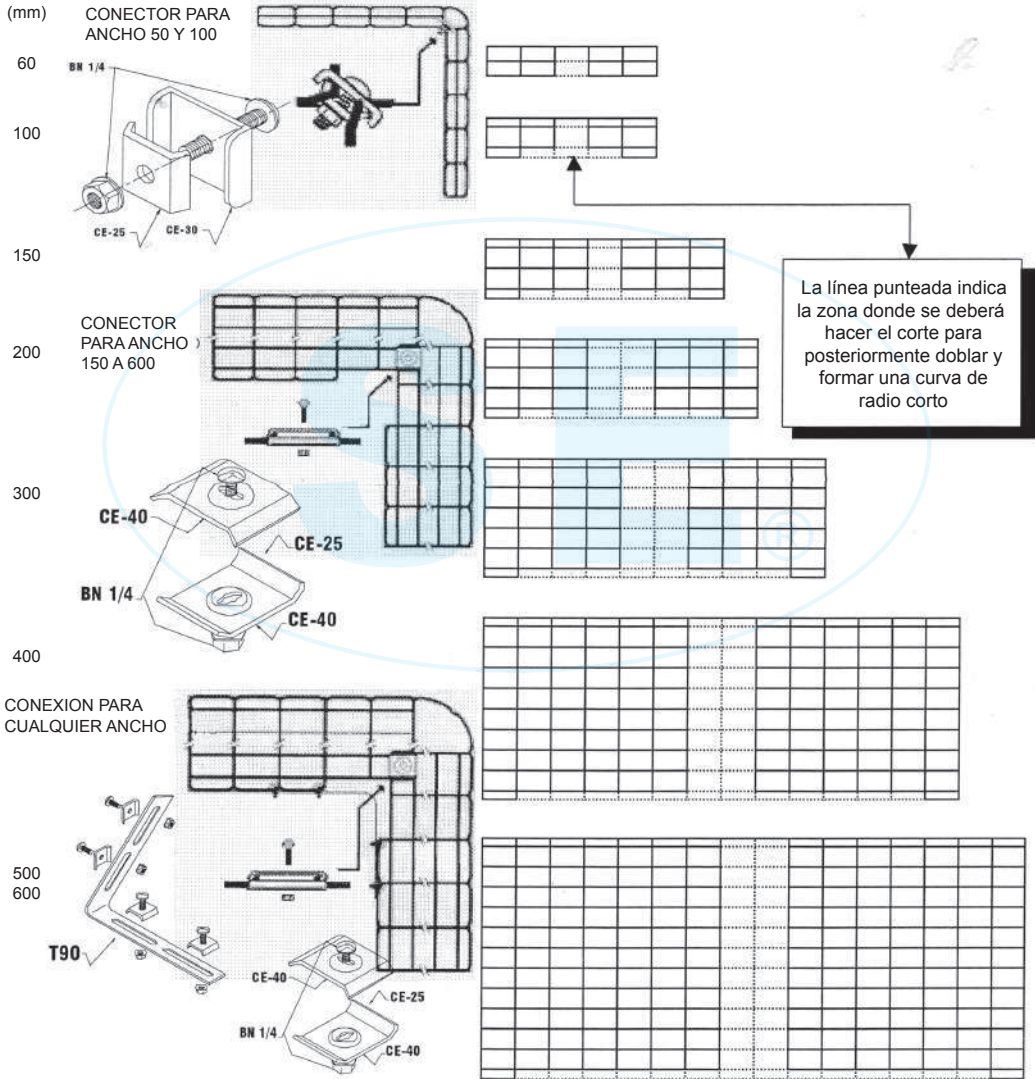

PRODUCTOS SOPORTES ELECTRICOS

ENSAMBLE DE "T" Y "X"



1 2 3 4 5

ZONAS A CORTAR

CHAROLA
INSERTADA



CONECTOR PARA
CUALQUIER ANCHO

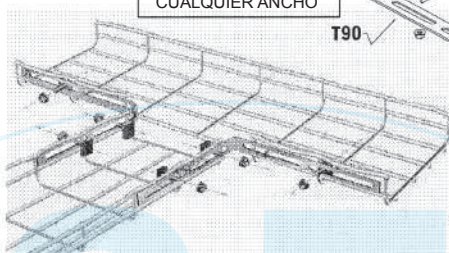
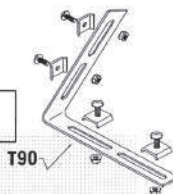

HORIZONTAL "T" AND "X"

EL FORMATO DE UNA "T" O "X" SE REALIZA CORTANDO ZONAS DE UN TRAMO RECTO; EL NUMERO DE ZONAS CORTADAS SE DETERMINA EN FUNCION DEL ANCHO DE LA CHAROLA INSERTADA

ANCHO DE CHAROLA INSERTADA	ZONAS A CORTAR
60	1
100	1
150	2
200	2
300	3
400	4
500	5
600	6

ESTA ES LA FORMA DE COLOCAR EL CONECTOR PARA FORMAR UNA TEE O UNA EQUIS HORIZONTAL EN LOS ANCHOS ESPECIFICADOS EN LA TABLA

ANCHO	CONECTOR A UTILIZAR	
	No. CAT	CANTIDAD
100		
200	CE-25	6
300	ED-250/90	2
400	BN 1/4	6
600		

SE DEBE UTILIZAR LA MISMA CANTIDAD DE ELEMENTOS DE CONEXION EN TODOS LOS ANCHOS

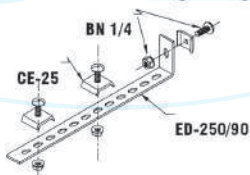

EL CONECTOR ED-250/90 SE COLOCARA DE ESTA MANERA PARA FORMAR UNA TEE O EQUIS HORIZONTAL SOLO CUANDO SE INSERTE UNA CHAROLA TIPO MALLA CON ANCHO 60, 150 Y 400

ANCHO	CONECTOR A UTILIZAR	
	No. CAT	CANTIDAD
60	CE-25	6
150	ED-250/90	2
400	BN 1/4	6

SE DEBE UTILIZAR LA MISMA CANTIDAD DE ELEMENTOS DE CONEXION EN TODOS LOS ANCHOS

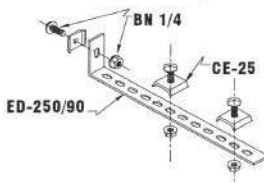
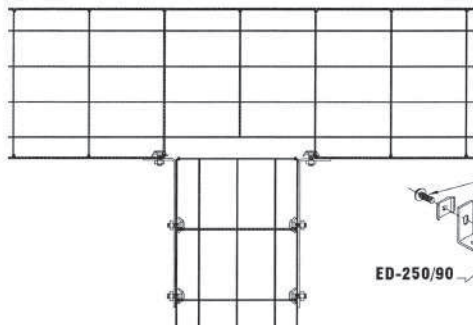

ENSAMBLE DE "T" Y "X"

HORIZONTAL "T" AND "X"

EL FORMADO DE UNA "T" O "X" DE RADIO ABIERTO SE REALIZA CORTANDO ZONAS DE UN TRAMO RECTO; EL NUMERO DE ZONAS CORTADAS SE DETERMINA EN FUNCION DEL ANCHO DE LA CHAROLA INSERTADA

CORTE DE CHAROLA TIPO MALLA No. 1

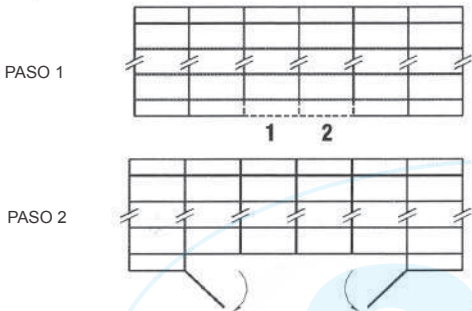

CORTE DE CHAROLA TIPO MALLA No. 2

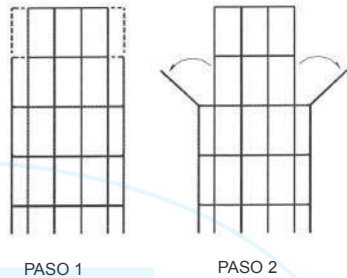

ANCHO DE CHAROLA No. 2	No. DE ZONAS A CORTAR EN LA CHAROLA No. 1
60	2
100	3
150	3
200	4
300	5
400	5
500	5
600	7

ANCHO DE 100, 200

USAR:
3 CUCL-01

BN 1/4

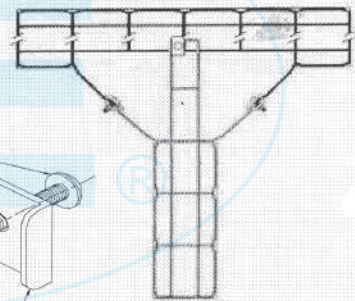
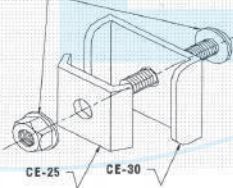

ANCHO DE 150

USAR:
1 CUCL-01,
4 CE-25,
4 BN-1/4 Y
2 ED-75

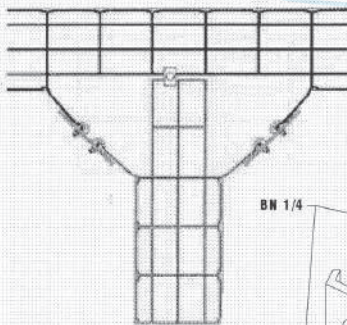

BN 1/4

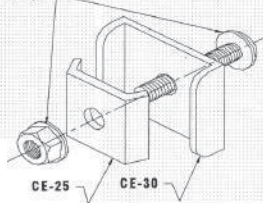

ANCHO DE 300 A 600

USAR:
4 CUCL-01

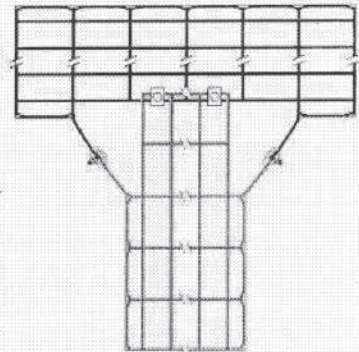

SECCION 2.- CANALETAS

SECTION 2.- CABLE CHANNEL

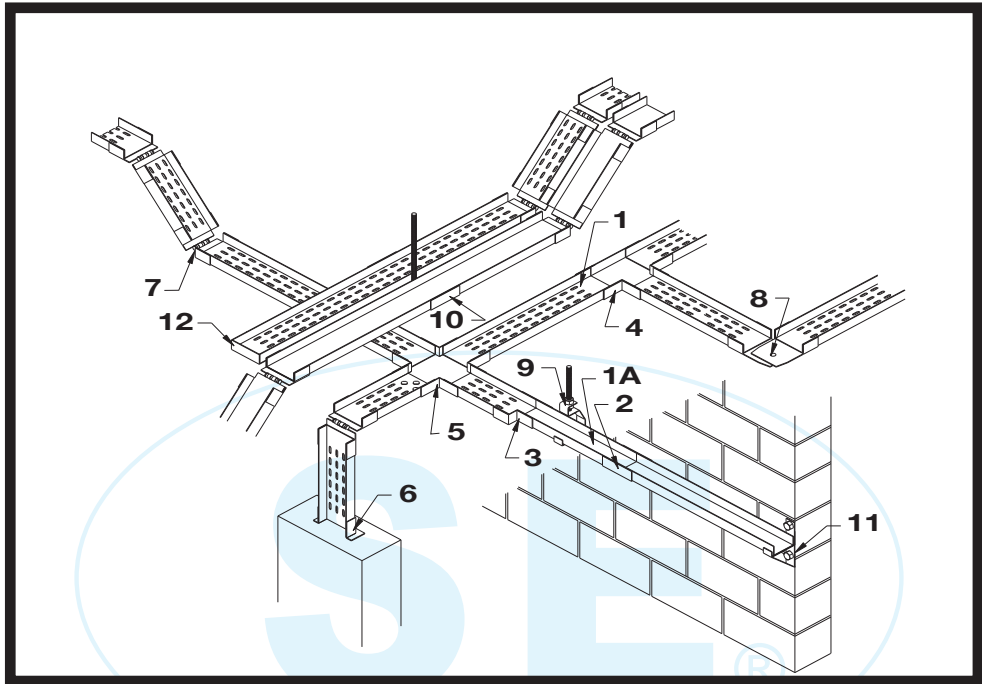

1.- TRAMO RECTO DE CANAL PERFORADO
SLOTTED CHANNEL STRAIGHT SECTION

7.- CONECTOR VERTICAL AJUSTABLE
VERTICAL ADJUSTABLE SPLICE PLATE

1A.- TRAMO RECTO DE CANAL SOLIDO
SOLID BOTTOM CHANNEL

8.- CONECTOR HORIZONTAL AJUSTABLE
HORIZONTAL ADJUSTABLE SPLICE PLATE

2.- CONECTOR U PARA CANAL
U SPLICE PLATE

9.- SOPORTE COLGANTE PARA CANAL
CHANNEL HANGER

3.- CONECTOR REDUCTOR PARA CANAL
REDUCER SPLICE PLATE

10.- SOPORTE DOBLE PARA CANAL
DOUBLE CHANNEL SUPPORT

4.- CONECTOR I PARA CANAL
I SPLICE PLATE

11.- MENSULA DE PARED
WALL CANTILEVER BRACKET

5.- CONECTOR X PARA CANAL
X SPLICE PLATE

12.- PLACA CIERRE PARA CANAL
CHANNEL BLIND END

6.- CONECTOR DE CANAL A CAJA
FRAME TYPE BOX CONNECTOR

SECCIONES

ANCHO NOMINAL WIDTH SIZE	TAMAÑO SIZE	CLASE NEMA / NEMA CLASS	
		ALUMINIO ALUMINUM	ACERO STEEL
76 (3)	3	5AA	5BB
102 (4)	4	6AA	6BB
152 (6)	6	6A	6B

SECTIONS

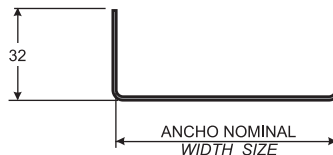

TRAMO RECTO

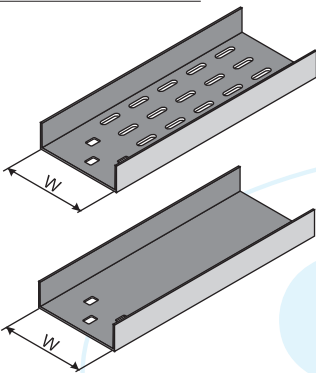

STRAIGHT SECTION

CHSV-3152GI

MATERIAL Y ACABADO / MATERIAL & FINISH
 LONGITUD EN cm / LENGHT IN cm
 ANCHO EN PULGADAS / WIDTH IN INCH
 TIPO DE FONDO / BOTTOOM TYPE
 TRAMO RECTO / STRAIGHT SECTION

INCLUYE UN CONECTOR AUCV Y TORNILLERIA
 AUCV CONNECTOR AND HARDWARE INCLUDED

NUMERO DE CATALOGO CATALOG NUMBER

ANCHO W WIDTH W	FONDO PERFORADO SLOTTED BOTTOOM		FONDO LISO SOLID BOTTOOM	
	LONGITUD LENGHT	LONGITUD LENGHT	LONGITUD LENGHT	LONGITUD LENGHT
	1524 (60)	3048 (120)	1524 (60)	3048 (120)
76 (3)	CHCV-3152	CHCV-3305	CHSV-3152	CHSV-3305
102 (4)	CHCV-4152	CHCV-4305	CHSV-4152	CHSV-4305
152 (6)	CHCV-6152	CHCV-6305	CHSV-6152	CHSV-6305

CONECTOR "U"

AUCV-3GI

MATERIAL Y ACABADO / MATERIAL & FINISH
 ANCHO EN PULGADAS / WIDTH IN INCH
 PARA CANALETA / CABLE CHANNEL FOR
 CONECTOR "U" / "U" SPLICE PLATE

N° DE CATALOGO CATALOG NUMBER	ANCHO W WIDTH W
AUCV-3	76 (3)
AUCV-4	102 (4)
AUCV-6	152 (6)

"U" SPLICE PLATE

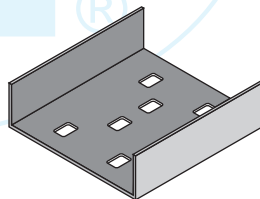

INCLUYE TORNILLERIA HARDWARE INCLUDED

MATERIALES Y ACABADOS DISPONIBLES:

- A:** ALUMINIO ALEACION AA-6063 ACABADO NATURAL
- GI:** ACERO AL CARBONO GALVANIZADO POR INMERSION EN CALIENTE SEGUN ASTM A 525
- GE:** ACERO AL CARBONO GALVANIZADO ELECTROLITICO SEGUN ASTM B 633
- T:** ACERO AL CARBONO TROPICALIZADO
- PVC:** ACERO AL CARBONO RECUBIERTO CON PVC SEGUN NEMA RN 1
- PVA:** ALUMINIO RECUBIERTO CON PVC SEGUN NEMA RN 1
- AI:** ACERO INOXIDABLE ACABADO NATURAL

MATERIALS & FINISHES AVAILABLE :

- A:** AA-6063 NATURAL FINISHED ALUMINUM
- GI:** HOT DIP GALVANIZED STEEL UNDER ASTM A 525
- GE:** ELECTROGALVANIZED STEEL UNDER ASTM B 633
- T:** CHROMIUM-ZINC COATED STEEL
- PVC:** PVC COATED STEEL UNDER NEMA RN 1
- PVA:** PVC COATED ALUMINUM UNDER NEMA RN 1
- AI:** NATURAL FINISHED STAINLESS STEEL

PARA MATERIALES Y ACABADOS NO INDICADOS CONSULTE NUESTRO DEPARTAMENTO DE INGENIERIA
 FOR MATERIALS AND FINISHES NOT SHOWN. PLEASE CONTACT OUR TECHNICAL DEPARTMENT

TODAS LAS DIMENSIONES EN mm (Pulg) / ALL DIMENSIONS ARE IN mm (Inch)

PUEDEN SER SUJETOS A MODIFICACION SIN PREVIO AVISO / MAY BE SUBJECT TO MODIFICATION WITHOUT NOTICE

CONECTOR "T"

ATCV-3GI

MATERIAL Y ACABADO(VER PAGINA 57)
 MATERIAL & FINISH (SEE PAGE 57)
 ANCHO EN PULGADAS / WIDTH IN INCH
 PARA CANALETA / CABLE CHANNEL FOR
 CONECTOR "T" / "T" SPLICE PLATE

N° DE CATALOGO CATALOG NUMBER	ANCHO W WIDTH W
ATCV-3	76 (3)
ATCV-4	102 (4)
ATCV-6	152 (6)

"T" SPLICE PLATE

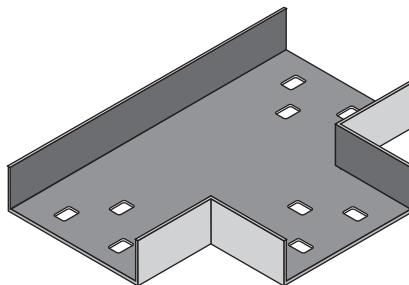

INCLUYE TORNILLERIA / HARDWARE INCLUDED

CONECTOR "X"

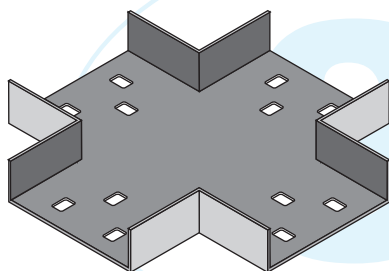

INCLUYE TORNILLERIA / HARDWARE INCLUDED

AXCV-3GI

MATERIAL Y ACABADO(VER PAGINA 57)
 MATERIAL & FINISH (SEE PAGE 57)
 ANCHO EN PULGADAS / WIDTH IN INCH
 PARA CANALETA / CABLE CHANNEL FOR
 CONECTOR "X" / "X" SPLICE PLATE

N° DE CATALOGO CATALOG NUMBER	ANCHO W WIDTH W
AXCV-3	76 (3)
AXCV-4	102 (4)
AXCV-6	152 (6)

"X" SPLICE PLATE

CONECTOR REDUCTOR

ARCV-63GI

MATERIAL Y ACABADO(VER PAGINA 57)
 MATERIAL & FINISH (SEE PAGE 57)
 ANCHO MENOR EN PULG. / SMALLEST WIDTH IN INCH
 ANCHO MAYOR EN PULG. / LARGEST WIDTH IN INCH
 PARA CANALETA / CABLE CHANNEL FOR
 CONECTOR REDUCTOR / REDUCER SPLICE PLATE

N° DE CATALOGO CATALOG NUMBER		
ANCHO W1 WIDTH W1	ANCHO W2 WIDTH W2	
102 (4)	ARCV-43	102 (4)
152 (6)	ARCV-63	ARCV-64

REDUCER SPLICE PLATE

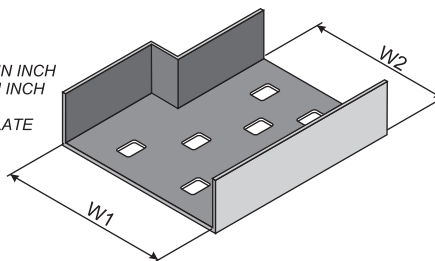

INCLUYE TORNILLERIA / HARDWARE INCLUDED

TODAS LAS DIMENSIONES EN mm (Pulg) / ALL DIMENSIONS ARE IN mm (Inch)
 PUEDE SER SUJETO A MODIFICACION SIN PREVIO AVISO / MAY BE SUBJECT TO MODIFICATION WITHOUT NOTICE

CONECTOR VERTICAL AJUSTABLE

AVACV-3GI

MATERIAL Y ACABADO(VER PAGINA 57)
 MATERIAL & FINISH (SEE PAGE 57)
 ANCHO EN PULGADAS / WIDTH IN INCH
 PARA CANALETA / CABLE CHANNEL FOR
 CONECTOR VERTICAL AJUSTABLE
 VERTICAL ADJUSTABLE SPLICE PLATE

N° DE CATALOGO CATALOG NUMBER	ANCHO W WIDTH W
AVACV-3	76 (3)
AVACV-4	102 (4)
AVACV-6	152 (6)

VERTICAL ADJUSTABLE SPLICE PLATE

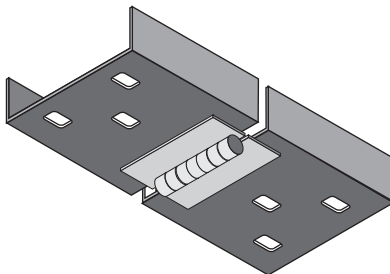

INCLUYE TORNILLERIA / HARDWARE INCLUDED

CONECTOR HORIZONTAL AJUSTABLE

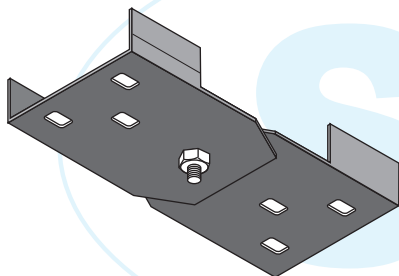

INCLUYE TORNILLERIA / HARDWARE INCLUDED

HORIZONTAL ADJUSTABLE SPLICE PLATE

AHACV-3GI

MATERIAL Y ACABADO(VER PAGINA 57)
 MATERIAL & FINISH (SEE PAGE 57)
 ANCHO EN PULGADAS / WIDTH IN INCH
 PARA CANALETA / CABLE CHANNEL FOR
 CONECTOR HORIZONTAL AJUSTABLE
 HORIZONTAL ADJUSTABLE SPLICE PLATE

N° DE CATALOGO CATALOG NUMBER	ANCHO W WIDTH W
AHACV-3	76 (3)
AHACV-4	102 (4)
AHACV-6	152 (6)

CONECTOR A CAJA

ACCV-3GI

MATERIAL Y ACABADO(VER PAGINA 57)
 MATERIAL & FINISH (SEE PAGE 57)
 ANCHO EN PULG. / WIDTH IN INCH
 PARA CANALETA / CABLE CHANNEL FOR
 CONECTOR A CAJA / FRAME BOX CONNECTOR

N° DE CATALOGO CATALOG NUMBER	ANCHO W WIDTH W
ACCV-3	76 (3)
ACCV-4	102 (4)
ACCV-6	152 (6)

FRAME BOX CONNECTOR

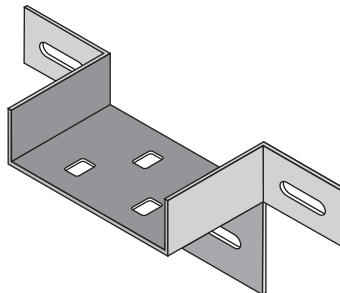

INCLUYE TORNILLERIA / HARDWARE INCLUDED

TODAS LAS DIMENSIONES EN mm (Pulg) / ALL DIMENSIONS ARE IN mm (Inch)
 PUEDE SER SUJETO A MODIFICACION SIN PREVIO AVISO / MAY BE SUBJECT TO MODIFICATION WITHOUT NOTICE

PLACA TERMINAL

BLIND END

PTRCV-3GI

MATERIAL Y ACABADO(VER PAGINA 57)
 MATERIAL & FINISH (SEE PAGE 57)
 ANCHO EN PULGADAS / WIDTH IN INCH
 PARA CANALETA / CABLE CHANNEL FOR
 PLACA TERMINAL / BLIND END

N° DE CATALOGO CATALOG NUMBER	ANCHO W WIDTH W
PTRCV-3	76 (3)
PTRCV-4	102 (4)
PTRCV-6	152 (6)

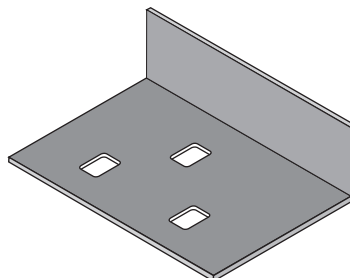

INCLUYE TORNILLERIA / HARDWARE INCLUDED

TAPAS

COVERS

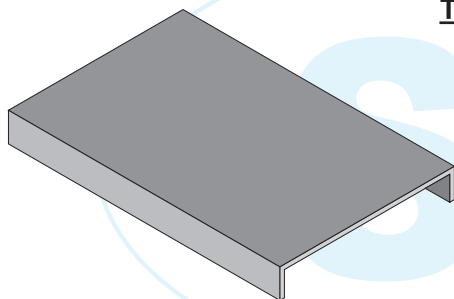

TCHCV-3152GI

MATERIAL Y ACABADO / MATERIAL & FINISH
 LONGITUD EN cm / LENGHT IN cm
 ANCHO EN PULGADAS / WIDTH IN INCH
 TIPO DE FONDO / BOTTOOM TYPE
 TAPA PARA TRAMO RECTO
 COVER FOR STRAIGHT SECTION

NUMERO DE CATALOGO
 CATALOG NUMBER

ANCHO W WIDTH W	LONGITUD LENGHT	LENGHT
76 (3)	1524 (60)	3048 (120)
102 (4)	CHCV-3152	CHCV-3305
152 (6)	CHCV-4152	CHCV-4305
	CHCV-6152	CHCV-6305

CLIP DE SUJECION PARA TAPA

COVER CLAMP

CSTCV-14GI

MATERIAL Y ACABADO(VER PAGINA 57)
 MATERIAL & FINISH (SEE PAGE 57)
 CLIP DE SUJECION PARA TAPA
 COVER CLAMP

INCLUYE TORNILLERIA / HARDWARE INCLUDED

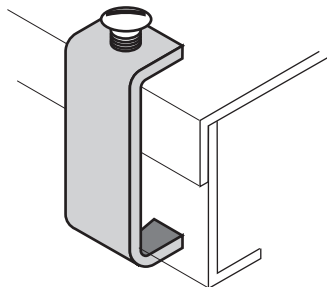

TODAS LAS DIMENSIONES EN mm (Pulg) / ALL DIMENSIONS ARE IN mm (Inch)
 PUEDE SER SUJETO A MODIFICACION SIN PREVIO AVISO / MAY BE SUBJECT TO MODIFICATION WITHOUT NOTICE

SECCION 2.2 - ACCESORIOS DE MONTAJE

SECTION 2.2 - CABLE CHANNEL SUPPORTS

MENSULA PARA PARED

WALL CANTILEVER BRACKET

MPCV-3GI

MATERIAL Y ACABADO(VER PAGINA 57 EXCEPTO ALUMINIO)
 MATERIAL & FINISH (SEE PAGE 57 EXCEPT ALUMINUM)
 ANCHO EN PULGADAS / WIDTH IN INCH
 PARA CANALETA / CABLE CHANNEL FOR
 MENSULA PARA PARED
 WALL CANTILEVER BRACKET

N° DE CATALOGO CATALOG NUMBER	ANCHO W WIDTH W
MPCV-3	76 (3)
MPCV-4	102 (4)
MPCV-6	152 (6)

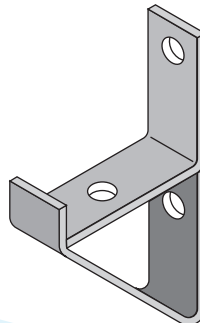

SOPORTE DOBLE

DOUBLE HANGER SUPPORT

SDCV-3GI

MATERIAL Y ACABADO(VER PAGINA 57 EXCEPTO ALUMINIO)
 MATERIAL & FINISH (SEE PAGE 57 EXCEPT ALUMINUM)
 ANCHO EN PULGADAS / WIDTH IN INCH
 PARA CANALETA / CABLE CHANNEL FOR
 SOPORTE DOBLE / DOUBLE SUPPORT

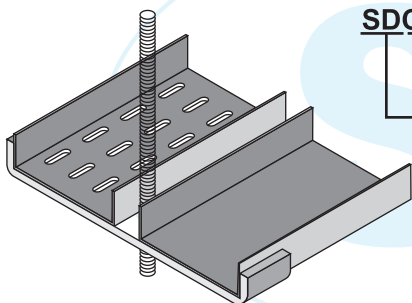

N° DE CATALOGO CATALOG NUMBER	ANCHO W WIDTH W
SDCV-3	76 (3)
SDCV-4	102 (4)
SDCV-6	152 (6)

SOPORTE COLGANTE

HANGER SUPPORT

SCCV-3GI

MATERIAL Y ACABADO(VER PAGINA 57 EXCEPTO ALUMINIO)
 MATERIAL & FINISH (SEE PAGE 57 EXCEPT ALUMINUM)
 ANCHO EN PULGADAS / WIDTH IN INCH
 PARA CANALETA / CABLE CHANNEL FOR
 SOPORTE COLGANTE / HANGER SUPPORT

N° DE CATALOGO CATALOG NUMBER	ANCHO W WIDTH W
SCCV-3	76 (3)
SCCV-4	102 (4)
SCCV-6	152 (6)

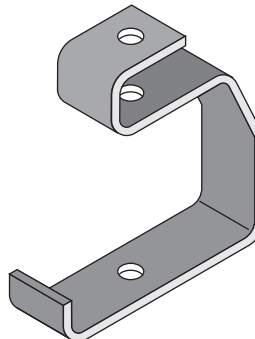

TODAS LAS DIMENSIONES EN mm (Pulg) / ALL DIMENSIONS ARE IN mm (Inch)
 PUEDE SER SUJETO A MODIFICACION SIN PREVIO AVISO / MAY BE SUBJECT TO MODIFICATION WITHOUT NOTICE

SECCION 4 DUCTOS CERRADOS

Producto de la experiencia de más de 25 años diseñando y fabricando sistemas de soportería para cables es esta nuestra línea de DUCTOS CERRADOS que SOPORTES ELECTRICOS ponen a su disposición.

Los ductos cerrados de SOPORTES ELECTRICOS cumplen con los más altos estándares de calidad y diseño para cumplir con sus necesidades de instalación de cables en lugares en los cuales existe la presencia de agentes externos dañinos como son químicos agresivos, proyecciones de objetos, circulación de vehículos, afluencia de animales extraños al sistema, etc.

Diseñados para cubrir las necesidades de áreas descritas por las normas nacionales e internacionales, tipos NEMA desde 1 hasta 12. con grados IP desde 30 hasta 67.

MATERIALES DE FABRICACIÓN

Los materiales de fabricación de los sistemas de ductos cerrados garantizan la protección efectiva de los cables, sin embargo es importante la selección del material en función de un ambiente específico, para tal propósito sugerimos la consulta del "Manual de selección correcta de un sistema de soportería para cables" editado por SOPORTES ELECTRICOS los materiales disponibles para la fabricación de ductos son : Acero al carbono, Acero inoxidable y Aluminio.

ACABADOS

Todos los ductos cerrados pueden ser fabricados con los siguientes acabados:

Natural para aluminio y acero inoxidable.

Galvanizado por inmersión en caliente según ASTM A 525 , Galvanizado electrolítico según ASTM B 633, Tropicalizado, esmalte electrostático, o époxico para acero al carbono. Para acabados especiales consulte a nuestro Departamento Técnico.

COMO SOLICITAR MATERIALES Y ACABADOS

De acuerdo al material y acabado se deberá adicionar un sufijo al número de catálogo mostrado en las paginas de este catálogo; los sufijos serán de acuerdo a lo siguiente:

Acero al carbono galvanizado por inmersión en caliente : **GI**
(cuando el espesor de la lámina permita el galvanizado después de fabricación sin distorsiones del producto se aplicara ASTM A 123, en caso contrario se aplicara ASTM A 525)

Acero al carbono galvanizado electrolítico según ASTM B 633 : **GE**

Acero al carbono tropicalizado : **T**

Acero al carbono con esmalte electrostatico : **P**

Acero al carbono acabado époxico : **PE**

Acero inoxidable acabado natural : **AI**

Aluminio acabado natural : **A**

DIMENSIONES

Las dimensiones indicadas en el contenido de este catálogo son en milímetros a menos que se especifique lo contrario. Las dimensiones entre paréntesis corresponden a su equivalencia en sistema ingles la cual deberá ser tomada como referencia y no como conversión de unidades.

Para cableado consulte la norma NOM-001 SEDE

SOPORTES ELECTRICOS se reserva el derecho de cambiar los diseños y dimensiones sin previo aviso.

SECTION 4 WIREWAY

Our WIREWAY line is product of 25 year of investigation, design, manufacturing cable support systems, for complies with the installation in areas were agree chemicals,, object projections, machines and animala are present.

Those wireways comply with national and international standard for areas type NEMA through 1 to 12 or protection grade IP through 30 to 67

MATERIALS OF MANUFACTURING

The wireway system is made of materials that garanty the efective cable protection, although is very important the material selection for the present and specific atmospheric enviroment, so we recomend cosult "Manual de selección correcta de un sistema de soportería para cables" Published for SOPORTES ELECTRICOS; The materials available for wireway system are : Carbon steel,Stainless steel and Aluminum

FINISHES

All the frames system components could be manufactured with the follow finishes:

Natural for Stainless steel and Aluminum.

ASTM A 123 Hot dip galvanized steel.

ASTM A 525 hot dip galvanized steel.

ASTM B 633 Electrogalvanized zinc steel.

Chromium/Zinc coated steel.

Electrostatic enamel or Epoxy coat steel.

For another finishes please consult our Technical Department.

HOW SPECIFY MATERIALS AND FINISHES

In accordance with the material and finish, you should put a suffix at the end of the catalog number, this suffix should be according with the follow:

Hot dip galvanized carbon steel : **GI**

(when the thickness of the material allow the galvanized after manufacturing whitout deformations the ASTM A 123 will be aplicated, and if not ASTM A 525 wil be aplicated)

Electrogalvanized carbon steel : **GE**

Carbon steel Chromium/zinc coated : **T**

Carbon steel electrostatic enamel coated : **P**

Carbon Steel epoxy coated : **PE**

Stainless steel natural finished : **AI**

Aluminum natural finished : **A**

DIMENSIONS

All dimensions are in milimeters unless otherwise specified.The dimensions in brackets are in english system only for reference.

For wiring please consult NEC code.

SOPORTES ELECTRICOS reserve the right to change the designs, dimensions or specifications without notice.

While every effort has been made to assure the accuracy of information contained in this catalogs at the time of publication, we can not accept responsibility for inaccuracies resulting from undetected errors or omissions.

SECCION 2.1 DUCTO CUADRADO NEMA 1/IP-30

SECCION 2.1 SQUARE WIREWAY NEMA 1/IP-30

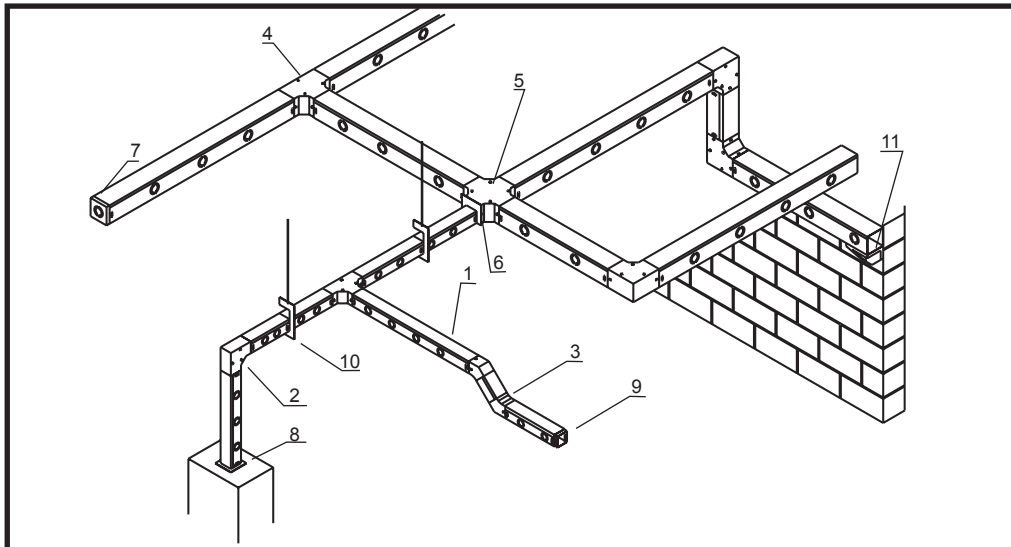

1.- TRAMO RECTO.- Será fabricado de acuerdo a los requerimientos del NOM-001 SEDE-2012 artículo 362. Consta de un cuerpo con discos removibles para derivaciones a tubo conduit, tapa embisagrada y ensamblada; En secciones de 65 X 65 mm, 100 X 100 mm, 150 X 150 mm, 203 X 203 mm Y 305 X 305 mm .

2.- CODO A 90°

3.- CODO A 45°.- Diseñados para efectuar cambios de dirección de la trayectoria por las necesidades propias de la instalación eléctrica o bien para seguir el contorno de la estructura del edificio. Todas las cubiertas laterales son removibles y están sostenidas por medio de tornillos. Las esquinas interiores de los codos están redondeadas para facilitar el jalado de los cables.

4.-TEE.- Diseñados para obtener derivaciones rectas a un solo lado. Todas las cubiertas y los laterales son removibles y están sostenidas por medio de tornillos.

5.-EQUIS.- Diseñados para obtener derivaciones rectas a ambos lados de la ruta principal. Todas las cubiertas y los laterales son removibles y están sostenidas por medio de tornillos. Las derivaciones no utilizadas pueden ser cerradas por medio de placas cierre.

6.- REDUCCIONES.- Con tapa embisagrada y para realizar cambio de sección en la trayectoria del sistema.

7.- PLACA CIERRE.- Para cerrar una salida para futuras conexiones o para terminar un tramo recto, con discos removibles para derivaciones a tubo conduit.

8.- ADAPTADOR A TABLERO.- Para conectar el ducto a gabinetes tales como centros de control de motores, controles de máquinas herramientas, tableros de alumbrado, de fuerza o de transición, un extremo del conector se surte con barrenos de fijación.

9.- CONECTOR.- Todos los conectores serán del tipo deslizante con la tapa conector embisagrada para acceso continuo a la cavidad del ducto.

10.- COLGADOR.- De acero protegido, están contruidos en una pieza para su instalación a techo con tensores o varilla roscada con adaptador.

11.- MENSULA.- De acero protegido, están contruidos en una pieza para su instalación a pared o lugar similar

1.- STRAIGHT SECTION.- It is made under NOM-001 SEDE-2012 articulo 362. It consist of a body with knockouts for conduit assembly and hinged cover, its available in the follow sections: 2 1/21 X 2 1/21, 41 X 41 mm, 61 X 61, 81 X 81 mm and 121 X 121 .

2.- 90° ELBOW

3.- 45° ELBOW.- They was designed for changes in the way of the system, for needs in project or for building conditions. all the parts can be removed and have screw support for union, the corners are rounded for carefull pull of the cables.

4.-TEE.- It was designed for right angle derivations to one side, all the parts can be removed and have screw support for union, the corners are rounded for carefull pull of the cables.

5.-EQUIS.- They was designed for right angle derivations to both sides, all the parts can be removed and have screw support for union, the corners are rounded for carefull pull of the cables. the derivations not used can be closed using a end blank.

6.- REDUCER.- With hinged cover for change section system .

7.- BLIND END .- With knockouts for conduit assembly, for close no used outlets, for future connections or close a system

8.- PANEL ADAPTER.- One end of adapter has holes for rigid and strong connection of wireway to gabinetes like control motor center, tool controls, lighting panel, power panel, etc.

9.- COUPLING.- The couplings are slide type with hinged cover for total acces to the cable system.

10.- HANGER.- Made of protected steel and manufactured in one piece for installation with threaded rod in ceiling

11.- BRACKET.- Made of protected steel and manufactured in one piece for wall instalation.

TRAMO RECTO EMBISAGRADO

No DE CATALOGO CATALOG NUMBER	DIMENSIONES DIMENSIONS		No DE CATALOGO CATALOG NUMBER	DIMENSIONES DIMENSIONS	
	A	L		A	L
DR-21	65 (2.5)	305 (12)	DR-65	150	1520 (60)
DR-22		610 (24)	DR-610	(6)	3048 (120)
DR-25		1520 (60)	DR-81	203 (8)	305 (12)
DR-210		3048 (120)	DR-82		610 (24)
DR-41	100 (4)	305 (12)	DR-85		1520 (60)
DR-42		610 (24)	DR-810		3048 (120)
DR-45		1520 (60)	DR-121	305 (12)	
DR-410		3048 (120)	DR-122	610 (24)	
DR-61	150 (6)	305 (12)	DR-125	1520 (60)	
DR-62		610 (24)	DR-1210	3048 (120)	

DR-6 5-P

MATERIAL Y ACABADO / MATERIAL & FINISHES
 LONGITUD EN PIES / LENGTH IN FEET
 DIMENSION NOMINAL / NOMINAL SIZE
 TRAMO RECTO / STRAIGHT SECTION

HINGED STRAIGHT SECTION

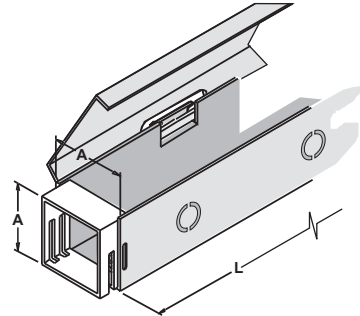

INCLUYE CONECTOR DCG CON TORNILLERIA
 DCG CONNECTOR AND HARDWARE INCLUDED

CONECTORES

No DE CATALOGO CATALOG NUMBER	SECCION DEL DUCTO WIREWAY SECTION
DCG-2	65 (2.5) X 65 (2.5)
DCG-4	100 (4) X 100 (4)
DCG-6	150 (6) X 150 (6)
DCG-8	203 (8) X 203 (8)
DCG-12	305 (12) X 305 (12)

DCG-6-P

MATERIAL Y ACABADO / MATERIAL & FINISHES
 DIMENSION NOMINAL / NOMINAL SIZE
 CONECTOR / CONNECTOR

CONNECTORS

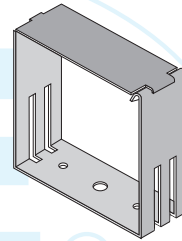

CODOS A 90°

No DE CATALOGO CATALOG NUMBER	SECCION DEL DUCTO WIREWAY SECTION	LONGITUD L LENGTH L
DC-290	65 (2.5) X 65 (2.5)	115 (4.528)
DC-490	100 (4) X 100 (4)	150 (5.906)
DC-690	150 (6) X 150 (6)	200 (7.875)
DC-890	203 (8) X 203 (8)	253 (9.962)
DC-1290	305 (12) X 305 (12)	355 (13.976)

DC-690-P

MATERIAL Y ACABADO / MATERIAL & FINISHES
 ANGULO DEL CODO 90° / 90° ELBOW ANGLE
 DIMENSION NOMINAL / NOMINAL SIZE
 CODO / ELBOW

90° ELBOW

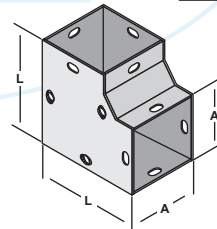

INCLUYE CONECTOR DCG CON TORNILLERIA
 DCG CONNECTOR AND HARDWARE INCLUDED

MATERIALES Y ACABADOS:

P : ACERO AL CARBONO / PINTURA ELECTROSTATICA
 COLOR GRIS ANSI-49

GI : LAMINA PREGALVANIZADA SEGUN ASTM-A 525

GE : ACERO AL CARBONO GALVANIZADO ELECTROLITICO
 SEGUN ASTM B 633

PVC: ACERO AL CARBONO RECUBIERTO CON PVC
 SEGUN NEMA RN 1

A: ALUMINIO ACABADO NATURAL

AI : ACERO INOXIDABLE ACABADO NATURAL

MATERIALS & FINISHES :

P : CARBON STEEL /ELECTROSTATIC
 GRAY ENAMEL ANSI 49

GI : GALVANIZED SHEET UNDER ASTM A 525

GE : ELECTROGALVANIZED STEEL UNDER ASTM B 633

PVC: PVC COATED STEEL UNDER NEMA RN 1

A: NATURAL FINISHED ALUMINUM

AI : NATURAL FINISHED STAINLESS STEEL

TODAS LAS DIMENSIONES EN mm (Pulg) / ALL DIMENSIONS ARE IN mm (Inch)

PUEDEN SER SUJETOS A MODIFICACION SIN PREVIO AVISO / MAY BE SUBJECT TO MODIFICATION WITHOUT NOTICE

CODOS A 45°

No DE CATALOGO CATALOG NUMBER	SECCION DEL DUCTO WIREWAY SECTION	LONGITUD L LENGHT L
DC-245	65 (2.5) X 65 (2.5)	160 (6.299)
DC-445	100 (4) X 100 (4)	200 (7.875)
DC-645	150 (6) X 150 (6)	230 (9.055)
DC-845	203 (8) X 203 (8)	295 (11.61)
DC-1245	305 (12) X 305 (12)	400 (15.74)

DC-645-P

MATERIAL Y ACABADO / MATERIAL & FINISHES
 ANGULO DEL CODO 45° / 45° ELBOW ANGLE
 DIMENSION NOMINAL / NOMINAL SIZE
 CODO ELBOW

45° ELBOW

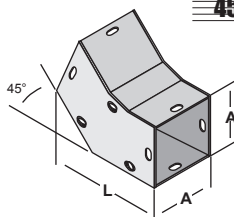

INCLUYE CONECTOR DCG CON TORNILLERIA
 DCG CONNECTOR AND HARDWARE INCLUDED

TEE

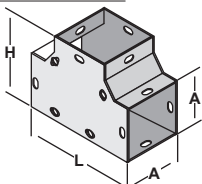

INCLUYE CONECTOR DCG CON TORNILLERIA
 DCG CONNECTOR AND HARDWARE INCLUDED

TEE

No DE CATALOGO CATALOG NUMBER	SECCION DEL DUCTO WIREWAY SECTION	LONGITUD L LENGHT L	ALTURA H HEIGHT H
DT-2	65 (2.5) X 65 (2.5)	165 (6.496)	115 (4.528)
DT-4	100 (4) X 100 (4)	200 (7.875)	150 (5.906)
DT-6	150 (6) X 150 (6)	250 (9.843)	200 (7.875)
DT-8	203 (8) X 203 (8)	303 (11.92)	253 (9.962)
DT-12	305 (12) X 305 (12)	405 (15.94)	355 (13.976)

DT-6-P

MATERIAL Y ACABADO / MATERIAL & FINISHES
 DIMENSION NOMINAL / NOMINAL SIZE
 TEE / TEE

EQUIS

No DE CATALOGO CATALOG NUMBER	SECCION DEL DUCTO WIREWAY SECTION	LONGITUD L LENGHT L
DX-2	65 (2.5) X 65 (2.5)	165 (6.496)
DX-4	100 (4) X 100 (4)	200 (7.875)
DX-6	150 (6) X 150 (6)	250 (9.843)
DX-8	203 (8) X 203 (8)	303 (11.92)
DX-12	305 (12) X 305 (12)	405 (15.94)

DX-6-P

MATERIAL Y ACABADO / MATERIAL & FINISHES
 DIMENSION NOMINAL / NOMINAL SIZE
 EQUIS / CROSS

CROSS

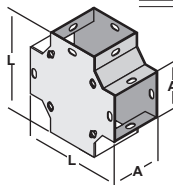

INCLUYE CONECTOR DCG CON TORNILLERIA
 DCG CONNECTOR AND HARDWARE INCLUDED

REDUCCION

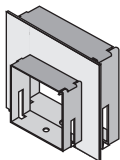

DRR-62-P

MATERIAL Y ACABADO / MATERIAL & FINISHES
 DIMENSION NOMINAL MENOR / SMALLER NOMINAL SIZE
 DIMENSION NOMINAL MAYOR / LARGER NOMINAL SIZE
 REDUCCION REDUCER

REDUCER

No DE CATALOGO CATALOG NUMBER	SECCION MAYOR LARGER SECTION	SECCION MENOR SMALLER SECTION
DRR-128	305 (12) X 305 (12)	203 (8) X 203 (8)
DRR-126	305 (12) X 305 (12)	150 (6) X 150 (6)
DRR-124	305 (12) X 305 (12)	100 (4) X 100 (4)
DRR-122	305 (12) X 305 (12)	65 (2.5) X 65 (2.5)
DRR-86	203 (8) X 203 (8)	150 (6) X 150 (6)
DRR-84	203 (8) X 203 (8)	100 (4) X 100 (4)
DRR-82	203 (8) X 203 (8)	65 (2.5) X 65 (2.5)
DRR-64	150 (6) X 150 (6)	100 (4) X 100 (4)
DRR-62	150 (6) X 150 (6)	65 (2.5) X 65 (2.5)
DRR-42	100 (4) X 100 (4)	65 (2.5) X 65 (2.5)

MATERIALES Y ACABADOS:

P: ACERO AL CARBONO / PINTURA ELECTROSTATICA
 COLOR GRIS ANSI-49
GI: LAMINA PREGALVANIZADA SEGUN ASTM-A 525
GE: ACERO AL CARBONO GALVANIZADO ELECTROLITICO
 SEGUN ASTM B 633
PVC: ACERO AL CARBONO RECUBIERTO CON PVC
 SEGUN NEMA RN 1
A: ALUMINIO ACABADO NATURAL
AI: ACERO INOXIDABLE ACABADO NATURAL

MATERIALS & FINISHES:

P: CARBON STEEL /ELECTROSTATIC
 GRAY ENAMEL ANSI 49
GI: GALVANIZED SHEET UNDER ASTM A 525
GE: ELECTROGALVANIZED STEEL UNDER ASTM B 633
PVC: PVC COATED STEEL UNDER NEMA RN 1
A: NATURAL FINISHED ALUMINUM
AI: NATURAL FINISHED STAINLESS STEEL

TODAS LAS DIMENSIONES EN mm (Pulg) / ALL DIMENSIONS ARE IN mm (Inch)

PUEDEN SER SUJETOS A MODIFICACION SIN PREVIO AVISO / MAY BE SUBJECT TO MODIFICATION WITHOUT NOTICE

PRODUCTOS SOPORTES ELECTRICOS

ADAPTADOR A TABLERO

No DE CATALOGO CATALOG NUMBER	SECCION DEL DUCTO WIREWAY SECTION
DA-2	65 (2.5) X 65 (2.5)
DA-4	100 (4) X 100 (4)
DA-6	150 (6) X 150 (6)
DA-8	203 (8) X 203 (8)
DA-12	305 (12) X 305 (12)

DA-6-P

MATERIAL Y ACABADO / MATERIAL & FINISHES
DIMENSION NOMINAL / NOMINAL SIZE
ADAPTADOR A TABLERO / PANEL ADAPTER

PANEL ADAPTER

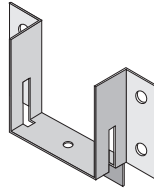

PLACA CIERRE

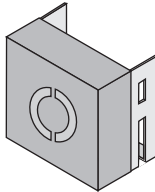

BLIND END

No DE CATALOGO CATALOG NUMBER	SECCION DEL DUCTO WIREWAY SECTION
DTC-2	65 (2.5) X 65 (2.5)
DTC-4	100 (4) X 100 (4)
DTC-6	150 (6) X 150 (6)
DTC-8	203 (8) X 203 (8)
DTC-12	305 (12) X 305 (12)

DTC-6-P

MATERIAL Y ACABADO / MATERIAL & FINISHES
DIMENSION NOMINAL / NOMINAL SIZE
PLACA CIERRE / BLIND END

MENSULA

No DE CATALOGO CATALOG NUMBER	SECCION DEL DUCTO WIREWAY SECTION
DM-2	65 (2.5) X 65 (2.5)
DM-4	100 (4) X 100 (4)
DM-6	150 (6) X 150 (6)
DM-8	203 (8) X 203 (8)
DM-12	305 (12) X 305 (12)

DM-6-P

MATERIAL Y ACABADO / MATERIAL & FINISHES
DIMENSION NOMINAL / NOMINAL SIZE
MENSULA / BRACKET

BRACKET

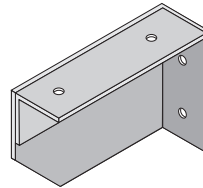

COLGADOR

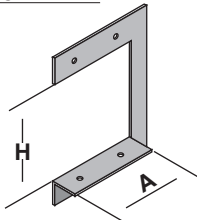

HANGER

No DE CATALOGO CATALOG NUMBER	ANCHO A WIDTH A	ALTURA H HEIGHT H
DH-2	63.5 (2.5)	190 (7.5)
DH-4	101.6 (4)	305 (12.0)
DH-6	152.4 (6)	454 (17.9)
DH-8	203 (8)	609 (24)
DH-12	305 (12)	915 (36)

DH-6-P

MATERIAL Y ACABADO / MATERIAL & FINISHES
DIMENSION NOMINAL / NOMINAL SIZE
COLGADOR / HANGER

MATERIALES Y ACABADOS:

P : ACERO AL CARBONO / PINTURA ELECTROSTATICA
COLOR GRIS ANSI-49

GI : LAMINA PREGALVANIZADA SEGUN ASTM-A 525

GE : ACERO AL CARBONO GALVANIZADO ELECTROLITICO
SEGUN ASTM B 633

PVC: ACERO AL CARBONO RECUBIERTO CON PVC
SEGUN NEMA RN 1

A: ALUMINIO ACABADO NATURAL

AI: ACERO INOXIDABLE ACABADO NATURAL

MATERIALS & FINISHES :

P : CARBON STEEL /ELECTROSTATIC
GRAY ENAMEL ANSI 49

GI : GALVANIZED SHEET UNDER ASTM A 525

GE : ELECTROGALVANIZED STEEL UNDER ASTM B 633

PVC: PVC COATED STEEL UNDER NEMA RN 1

A: NATURAL FINISHED ALUMINUM

AI: NATURAL FINISHED STAINLESS STEEL

TODAS LAS DIMENSIONES EN mm (Pulg) / ALL DIMENSIONS ARE IN mm (Inch)

PUEDO SER SUJETO A MODIFICACION SIN PREVIO AVISO / MAY BE SUBJECT TO MODIFICATION WITHOUT NOTICE

SECCION 4.2 DUCTO CON TAPA A PRESION NEMA 1 / IP-40

SECCION 4.2 PRESSED COVER WIREWAY NEMA 1 / IP-40

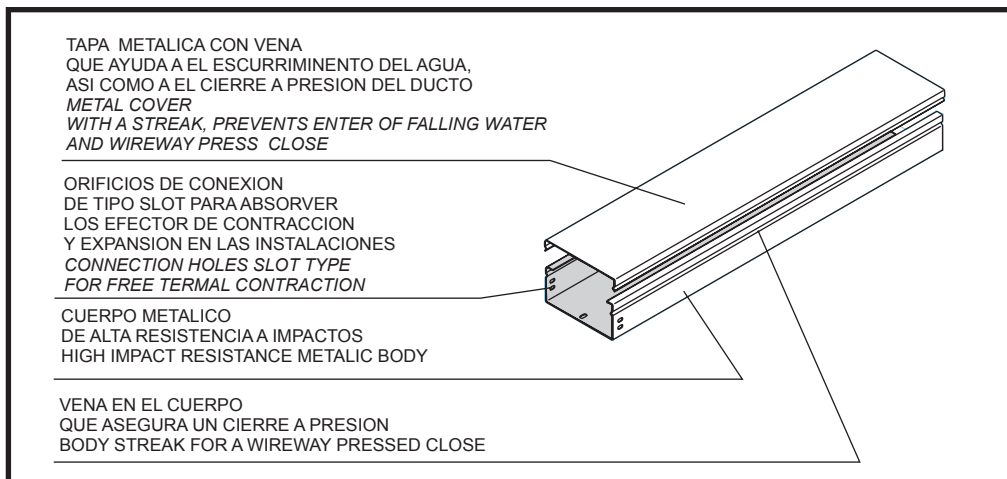

CARACTERÍSTICAS GENERALES

El ducto con tapa a presión SOPORTES ELECTRICOS es un sistema de canalización de cables metálico de uso interior que ofrece protección contra daño mecánico a cables tanto de fuerza como de control y señalización.

Este sistema cumple las características indicadas para áreas tipo NEMA 1 y cuenta con un índice de protección IP 40 de acuerdo con IEC 60529. lo cual lo hace ideal en instalaciones sujetas a proyecciones de objetos.

Por la forma de conexión el sistema cuenta con acceso completo sin necesidad de jalado de cables.

La ausencia de bisagras lo hace ideal para cortes, ya que el corte nunca coincidirá con la bisagra.

La tapa siempre asegura un cierre uniforme en cualquier punto de la trayectoria.

Las salidas para tubería conduit pueden realizarse en campo en cualquier punto del sistema sin afectar sus características de protección.

Mayor flexibilidad, facilidad de instalación, una amplia variedad de materiales, accesorios, etc. además de una gran duración son las características que hacen del sistema de ductos con tapa a presión SOPORTES ELECTRICOS la solución ideal para su instalación ya sea industrial, comercial o de oficinas sujeta a proyección de objetos sólidos.

MATERIALES DE FABRICACION

El ducto con tapa a presión SOPORTES ELECTRICOS esta disponible en acero al carbono galvanizado de acuerdo a ASTM A 525, acero inoxidable y aluminio. Para materiales diferentes consulte nuestro Departamento Técnico.

SOPORTES ELECTRICOS se reserva el derecho de modificar los diseños, dimensiones, así como la información contenida en este catálogo sin previo aviso.

FEATURES

The SOPORTES ELECTRICOS pressed cover wireway is a metallic wiring system for indoor uses that provide cable protection against mechanical damage in power, control and signal systems.

This system covers NEMA 1 standard and IP 40 under IEC 60529. It's ideal for installation under conditions of projections objects.

No pulling through of wires or cables is required with the SOPORTES ELECTRICOS cover presses wireway.

The wireway can be cutted easily, because it do'nt have hinges.

The conduit outlet are field made at any point of the system without affect the protection properties

More flexibility, easy instalation, wide kind of accesories and materials. for all this the SOPORTES ELECTRICOS cover pressed wireway is the best solution for an objets falling instalation.

MANUFACTURING MATERIALS

The SOPORTES ELECTRICOS cover pressed wireway is available in galvanized carbon steel under ASTM A 525, stainless steel and aluminum . For another materials please consult our Technical Department.

SOPORTES ELECTRICOS reserve the right to change the designs, dimensions or specifications without notice.

While every effort has been made to assure the accuracy of information contained in this catalogs at the time of publication, we can not accept responsibility for inaccurates resulting from undetected errors or omissions.

PRODUCTOS SOPORTES ELECTRICOS

TRAMO RECTO

No DE CATALOGO CATALOG NUMBER	DIMENSIONES DIMENSIONS		LARGO LENGTH
	A	H	
DTP-7575	75 (3)	75	1500
DTP-15075	150 (6)	(3)	3000
DTP-30075	300 (12)		

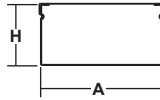

STRAIGHT SECTION

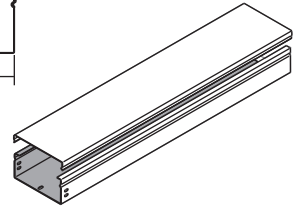

DTP-15075-1.5-GI

MATERIAL Y ACABADO / MATERIAL & FINISHES
 LONGITUD EN METROS / LENGTH IN METERS
 DISPONIBLE EN 1.5 Y 3.0 m / AVAILABLE IN 1.5 & 3.0 m
 PERALTE / HEIGHT
 ANCHO / WIDTH
 TRAMO RECTO / STRAIGHT SECTION

INCLUYE 2 CONECTORES ARDTP CON TORNILLERIA
 TWO ARDTP CONNECTORS AND HARDWARE INCLUDED

CODO HORIZONTAL A 90°

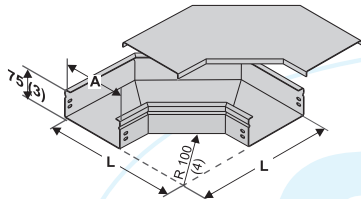

DVHTP-15075-90-GI

INCLUYE 2 CONECTORES ARDTP CON TORNILLERIA
 TWO ARDTP CONNECTORS AND HARDWARE INCLUDED

MATERIAL Y ACABADO / MATERIAL & FINISHES
 ANGULO DE LA CURVA 90° / ELBOW ANGLE 90°
 PERALTE / HEIGHT
 ANCHO / WIDTH
 CODO HORIZONTAL / HORIZONTAL ELBOW

90° HORIZONTAL ELBOW

No DE CATALOGO CATALOG NUMBER	DIMENSIONES DIMENSIONS	
	A	L
DVHTP-7575-90	75 (3)	205 (8)
DVHTP-15075-90	150 (6)	280 (11)
DVHTP-30075-90	300 (12)	430 (17)

CODO HORIZONTAL A 45°

No DE CATALOGO CATALOG NUMBER	DIMENSIONES DIMENSIONS	
	A	L
DVHTP-7575-45	75 (3)	205 (8)
DVHTP-15075-45	150 (6)	280 (11)
DVHTP-30075-45	300 (12)	430 (17)

DVHTP-15075-45-GI

MATERIAL Y ACABADO / MATERIAL & FINISHES
 ANGULO DE LA CURVA 45° / ELBOW ANGLE 45°
 PERALTE / HEIGHT
 ANCHO / WIDTH
 CODO HORIZONTAL / HORIZONTAL ELBOW

45° HORIZONTAL ELBOW

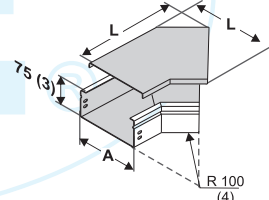

INCLUYE 2 CONECTORES ARDTP CON TORNILLERIA
 TWO ARDTP CONNECTORS AND HARDWARE INCLUDED

TEE HORIZONTAL

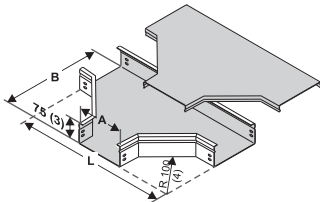

INCLUYE 2 CONECTORES ARDTP CON TORNILLERIA
 TWO ARDTP CONNECTORS AND HARDWARE INCLUDED

No DE CATALOGO CATALOG NUMBER	DIMENSIONES DIMENSIONS		
	A	B	L
DTHTP-7575	75 (3)	205 (8)	335 (13.19)
DTHTP-15075	150 (6)	280 (11)	410 (16.14)
DTHTP-30075	300 (12)	430 (17)	560 (22.04)

DTHTP-15075-GI

MATERIAL Y ACABADO / MATERIAL & FINISHES
 PERALTE / HEIGHT
 ANCHO / WIDTH
 TEE HORIZONTAL / HORIZONTAL TEE

HORIZONTAL TEE

MATERIALES Y ACABADOS:
 GI : LAMINA PREGALVANIZADA SEGUN ASTM-A 525
 P : ACERO AL CARBONO / PINTURA ELECTROSTATICA GRIS ANSI-49
 A : ALUMINIO ACABADO NATURAL
 AI : ACERO INOXIDABLE ACABADO NATURAL

MATERIALS & FINISHES :
 GI : GALVANIZED SHEET UNDER ASTM A 525
 P : CARBON STEEL / ELECTROSTATIC GRAY ENAMEL ANSI-49
 A : NATURAL FINISHED ALUMINUM
 AI : NATURAL FINISHED STAINLESS STEEL

TODAS LAS DIMENSIONES EN mm (Pulg) / ALL DIMENSIONS ARE IN mm (Inch)
 PUEDE SER SUJETO A MODIFICACION SIN PREVIO AVISO / MAY BE SUBJECT TO MODIFICATION WITHOUT NOTICE

EQUIS HORIZONTAL

No DE CATALOGO CATALOG NUMBER	DIMENSIONES DIMENSIONS	
	A	L
DXHTP-7575-45	75 (3)	335 (13.19)
DXHTP-15075-45	150 (6)	410 (16.14)
DXHTP-30075-45	300 (12)	560 (22.04)

INCLUYE 2 CONECTORES ARDTP CON TORNILLERIA
TWO ARDTP CONNECTORS AND HARDWARE INCLUDED

HORIZONTAL CROSS

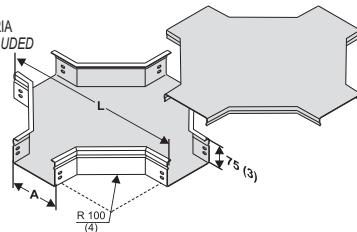

DXHTP-15075-GI

MATERIAL Y ACABADO / MATERIAL & FINISHES°
PERALTE / HEIGHT
ANCHO / WIDTH
EQUIS HORIZONTAL / HORIZONTAL CROSS

REDUCCION RECTA

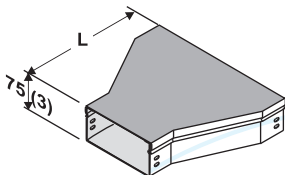

INCLUYE 2 CONECTORES ARDTP CON TORNILLERIA
TWO ARDTP CONNECTORS AND HARDWARE INCLUDED

CODO VERTICAL INTERIOR A 90°

No DE CATALOGO CATALOG NUMBER	DIMENSIONES DIMENSIONS	
	A	L
DVITP-7575-90	75 (3)	205
DVITP-15075-90	150 (6)	(8)
DVITP-30075-90	300 (12)	

DVITP-15075-90-GI

MATERIAL Y ACABADO / MATERIAL & FINISHES°
ANGULO DE LA CURVA 90° / ELBOW ANGLE 90°
PERALTE / HEIGHT
ANCHO / WIDTH
CURVA VERTICAL INTERIOR / INSIDE VERTICAL ELBOW

CODO VERTICAL EXTERIOR A 90°

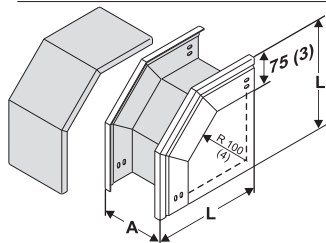

INCLUYE 2 CONECTORES ARDTP CON TORNILLERIA
TWO ARDTP CONNECTORS AND HARDWARE INCLUDED

DVETP-15075-90-GI

MATERIAL Y ACABADO / MATERIAL & FINISHES°
ANGULO DE LA CURVA 90° / ELBOW ANGLE 90°
PERALTE / HEIGHT
ANCHO / WIDTH
CURVA VERTICAL EXTERIOR / OUTSIDE VERTICAL ELBOW

STRAIGHT REDUCER

No DE CATALOGO CATALOG NUMBER	ANCHO MAYOR LARGER WIDTH	ANCHO MENOR SMALLER WIDTH	L
DRLTP-300150	300 (12)	150 (6)	220 (8.66)
DRLTP-30075	300 (12)	75 (3)	440 (17.3)
DRLTP-15075	150 (6)	75 (3)	440 (1.3)

DRLTP-15075-GI

MATERIAL Y ACABADO / MATERIAL & FINISHES°
ANCHO MENOR / SMALLER WIDTH
ANCHO MAYOR / LARGER WIDTH
REDUCCION RECTA / STRAIGHT REDUCER

90° INSIDE VERTICAL ELBOW

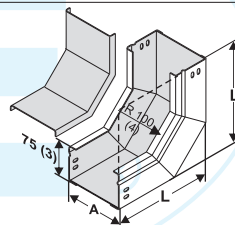

INCLUYE 2 CONECTORES ARDTP CON TORNILLERIA
TWO ARDTP CONNECTORS AND HARDWARE INCLUDED

90° OUTSIDE VERTICAL ELBOW

No DE CATALOGO CATALOG NUMBER	DIMENSIONES DIMENSIONS	
	A	L
DVETP-7575-90	75 (3)	205
DVETP-15075-90	150 (6)	(8)
DVETP-30075-90	300 (12)	

MATERIALES Y ACABADOS:
GI : LAMINA PREGALVANIZADA SEGUN ASTM-A 525
P: ACERO AL CARBONO / PINTURA ELECTROSTATICA GRIS ANSI-49
A: ALUMINIO ACABADO NATURAL
AI : ACERO INOXIDABLE ACABADO NATURAL

MATERIALS & FINISHES :
GI : GALVANIZED SHEET UNDER ASTM A 525
P: CARBON STEEL / ELECTROSTATIC GRAY ENAMEL ANSI-49
A: NATURAL FINISHED ALUMINUM
AI : NATURAL FINISHED STAINLESS STEEL

TODAS LAS DIMENSIONES EN mm (Pulg) / ALL DIMENSIONS ARE IN mm (Inch)
PUEDEN SER SUJETOS A MODIFICACION SIN PREVIO AVISO / MAY BE SUBJECT TO MODIFICATION WITHOUT NOTICE

TEE VERTICAL

No DE CATALOGO CATALOG NUMBER	DIMENSIONES DIMENSIONS	
	A	L
DTVTP-7575-45	75 (3)	335
DTVTP-15075-45	150 (6)	(13.19)
DTVTP-30075-45	300 (12)	

INCLUYE 2 CONECTORES ARDTP CON TORNILLERIA
TWO ARDTP CONNECTORS AND HARDWARE INCLUDED

DTVTP-15075-GI

MATERIAL Y ACABADO / MATERIAL & FINISHES°
PERALTE / HEIGHT
ANCHO / WIDTH
TEE VERTICAL / VERTICAL TEE

VERTICAL TEE

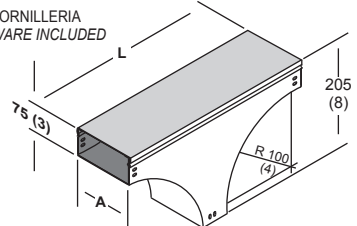

BLIND END

TAPA TERMINAL

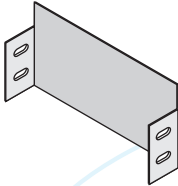

No DE CATALOGO CATALOG NUMBER
TTDTP-7575
TTDTP-15075
TTDTP-30075

TTDTP-15075-GI

MATERIAL Y ACABADO / MATERIAL & FINISHES
PERALTE / HEIGHT
ANCHO / WIDTH
TAPA TERMINAL / BLIND END

INCLUYE TORNILLERIA / HARDWARE INCLUDED

ADAPTADOR A TABLERO

PANEL ADAPTER

No DE CATALOGO CATALOG NUMBER
ADTP-7575
ADTP-15075
ADTP-30075

ADTP-15075-GI

MATERIAL Y ACABADO / MATERIAL & FINISHES
PERALTE / HEIGHT
ANCHO / WIDTH
ADAPTADOR A TABLERO / PANEL ADAPTER

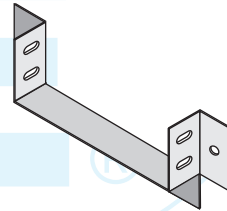

INCLUYE TORNILLERIA / HARDWARE INCLUDED

CONECTOR RECTO

STRAIGHT CONNECTOR

CLIP DE SEGURIDAD PARA TAPA

COVER LOCK CLAMP

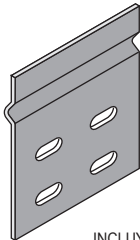

ARDTP

INCLUYE TORNILLERIA / HARDWARE INCLUDED

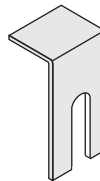

DTP-CLPT

NO INCLUYE TORNILLERIA / HARDWARE NOT INCLUDED

MATERIALES Y ACABADOS:

GI : LAMINA PREGALVANIZADA SEGUN ASTM-A 525
P: ACERO AL CARBONO / PINTURA ELECTROSTATICA GRIS ANSI-49
A: ALUMINIO ACABADO NATURAL
AI : ACERO INOXIDABLE ACABADO NATURAL

MATERIALS & FINISHES :

GI : GALVANIZED SHEET UNDER ASTM A 525
P: CARBON STEEL / ELECTROSTATIC GRAY ENAMEL ANSI-49
A: NATURAL FINISHED ALUMINUM
AI : NATURAL FINISHED STAINLESS STEEL

TODAS LAS DIMENSIONES EN mm (Pulg) / ALL DIMENSIONS ARE IN mm (Inch)

SECCION 4.3 DUCTO CON VENA Y CAÑUELA NEMA 5, 12/ IP-54

SECCION 4.3 PACKED AND PRESSED WIREWAY NEMA 5, 12/ IP-54

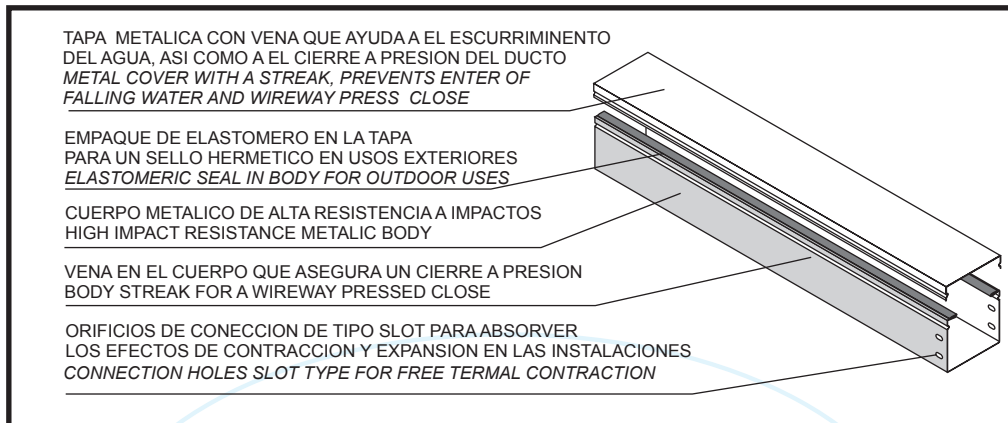

CARACTERÍSTICAS GENERALES

El ducto con vena y cañuela SOPORTES ELECTRICOS es un sistema de canalización de cables metálico que ofrece protección contra daño mecánico; polvo, suciedad, aceite y/o agua a cables tanto de fuerza como de control y señalización.

Este sistema cumple las características indicadas para áreas tipo NEMA 5 y 12 y cuenta con un índice de protección IP 54 de acuerdo con IEC 60529.

Por la forma de conexión el sistema cuenta con acceso completo sin necesidad de jalado de cables.

La ausencia de bisagras lo hace ideal para cortes, ya que el corte nunca coincidirá con la bisagra.

La tapa siempre asegura un cierre uniforme en cualquier punto de la trayectoria.

Las salidas para tubería conduit pueden realizarse en campo en cualquier punto del sistema sin afectar sus características de protección.

Mayor flexibilidad, facilidad de instalación, una amplia variedad de materiales, accesorios, etc. además de una gran duración son las características que hacen del sistema de ductos con tapa a presión SOPORTES ELECTRICOS la solución ideal para su instalación donde se presenten goteo de agua o aceite, así como caída de suciedad o polvo.

MATERIALES DE FABRICACIÓN

El ducto con vena y cañuela SOPORTES ELECTRICOS está disponible en acero al carbono con acabado en esmalte electrostático gris ANSI 49, acero al carbono galvanizado electrolítico según ASTM B 633, acero inoxidable y aluminio. Para materiales diferentes consulte nuestro Departamento Técnico.

SOPORTES ELECTRICOS se reserva el derecho de modificar los diseños, dimensiones, así como la información contenida en este.

FEATURES

The SOPORTES ELECTRICOS packed and pressed cover wireway is a metallic wiring system that provide cable protection against mechanical damage, dust, dirt, oil or water in power, control and signal systems.

This system covers NEMA 5 and 12 standard and IP 54 under IEC 60529.

No pulling through of wires or cables is required with the SOPORTES ELECTRICOS packed and pressed wireway. The wireway can be cutted easily, because it don't have hinges. The conduit outlet are field made at any point of the system without affect the protection properties

More flexibility, easy installation, wide kind of accesories and materials. For all this the SOPORTES ELECTRICOS cover pressed and packed wireway is the best solution for a projection objects, oil or water drop or dirt or dust falling installation.

MANUFACTURING MATERIALS

The SOPORTES ELECTRICOS cover packed and pressed wireway is available in electro enamel gray ANSI 49 carbon steel , electrogalvanized under ASTM B 633 carbon steel, stainless steel and aluminum . For another materials please consult our Technical Department.

SOPORTES ELECTRICOS reserve the right to change the designs, dimensions or specifications without notice.

While every effort has been made to assure the accuracy of information contained in this catalog at the time of publication, we can not accept responsibility for inaccuracies resulting from undetected errors or omissions.

PRODUCTOS SOPORTES ELECTRICOS

TRAMO RECTO

No DE CATALOGO CATALOG NUMBER	DIMENSIONES DIMENSIONS		No DE CATALOGO CATALOG NUMBER	DIMENSIONES DIMENSIONS	
	A	L		A	L
DVCR-21	65 (2.5)	305 (12)	DVCR-65	150 (6)	1520 (60)
DVCR-22		610 (24)	DVCR-610		3048 (120)
DVCR-25		1520 (60)	DVCR-81	203 (8)	305 (12)
DVCR-210		3048 (120)	DVCR-82		610 (24)
DVCR-41	100 (4)	305 (12)	DVCR-85		1520 (60)
DVCR-42		610 (24)	DVCR-810	3048 (120)	
DVCR-45		1520 (60)	DVCR-121	305 (12)	
DVCR-410	150 (6)	3048 (120)	DVCR-122	305 (12)	610 (24)
DVCR-61		305 (12)	DVCR-125		1520 (60)
DVCR-62		610 (24)	DVCR-1210		3048 (120)

DVCR-6 5-P

MATERIAL Y ACABADO / MATERIAL & FINISHES
 LONGITUD EN PIES / LENGTH IN FEET
 DIMENSION NOMINAL / NOMINAL SIZE
 TRAMO RECTO / STRAIGHT SECTION

STRAIGHT SECTION

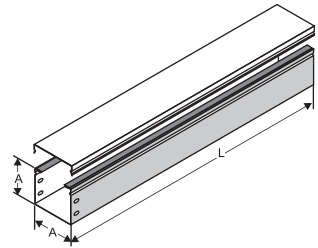

INCLUYE CONECTOR DVCG CON TORNILLERIA
 DVCG CONNECTOR AND HARDWARE INCLUDED

CONECTORES

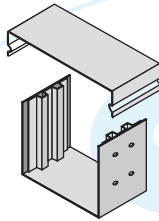

TORNILLERIA INCLUIDA / HARDWARE INCLUDED

CONNECTORS

No DE CATALOGO CATALOG NUMBER	SECCION DEL DUCTO WIREWAY SECTION
DVCG-2	65 (2.5) X 65 (2.5)
DVCG-4	100 (4) X 100 (4)
DVCG-6	150 (6) X 150 (6)
DVCG-8	203 (8) X 203 (8)
DVCG-12	305 (12) X 305 (12)

DVCG-6-P

MATERIAL Y ACABADO / MATERIAL & FINISHES
 DIMENSION NOMINAL / NOMINAL SIZE
 CONECTOR / CONNECTOR

CODOS A 90°

No DE CATALOGO CATALOG NUMBER	SECCION DEL DUCTO WIREWAY SECTION
DVCC-290	65 (2.5) X 65 (2.5)
DVCC-490	100 (4) X 100 (4)
DVCC-690	150 (6) X 150 (6)
DVCC-890	203 (8) X 203 (8)
DVCC-1290	305 (12) X 305 (12)

DVCC-690-P

MATERIAL Y ACABADO / MATERIAL & FINISHES
 ANGULO DEL CODO 90° / 90° ELBOW ANGLE
 DIMENSION NOMINAL / NOMINAL SIZE
 CODOHORIZONTAL / HORIZONTAL ELBOW

90° ELBOW

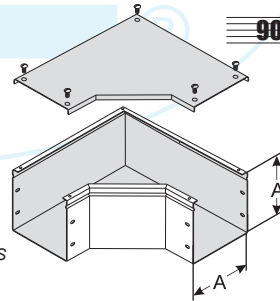

INCLUYE CONECTOR DVCG CON TORNILLERIA
 DVCG CONNECTOR AND HARDWARE INCLUDED

MATERIALES Y ACABADOS:

P : ACERO AL CARBONO / PINTURA ELECTROSTATICA
 COLOR GRIS ANSI-49

GE : ACERO AL CARBONO GALVANIZADO ELECTROLITICO
 SEGUN ASTM B 633

A : ALUMINIO ACABADO NATURAL

AI : ACERO INOXIDABLE ACABADO NATURAL

MATERIALS & FINISHES :

P : CARBON STEEL /ELECTROSTATIC
 GRAY ENAMEL ANSI 49

GE : ELECTROGALVANIZED STEEL UNDER ASTM B 633

A : NATURAL FINISHED ALUMINUM

AI : NATURAL FINISHED STAINLESS STEEL

TODAS LAS DIMENSIONES EN mm (Pulg) / ALL DIMENSIONS ARE IN mm (Inch)

PUEDEN SER SUJETOS A MODIFICACION SIN PREVIO AVISO / MAY BE SUBJECT TO MODIFICATION WITHOUT NOTICE

CODOS A 45°

No DE CATALOGO CATALOG NUMBER	SECCION DEL DUCTO WIREWAY SECTION
DVCC-245	65 (2.5) X 65 (2.5)
DVCC-445	100 (4) X 100 (4)
DVCC-645	150 (6) X 150 (6)
DVCC-845	203 (8) X 203 (8)
DVCC-1245	305 (12) X 305 (12)

DVCC-645-P

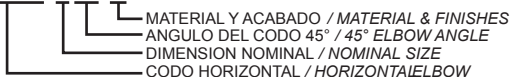

45° ELBOW

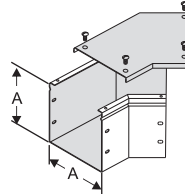

INCLUYE CONECTOR DVCG CON TORNILLERIA
DVCG CONNECTOR AND HARDWARE INCLUDED

TEE HORIZONTAL

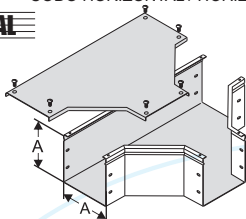

INCLUYE CONECTOR DVCG CON TORNILLERIA
DVCG CONNECTOR AND HARDWARE INCLUDED

HORIZONTAL TEE

No DE CATALOGO CATALOG NUMBER	SECCION DEL DUCTO WIREWAY SECTION
DVCTH-2	65 (2.5) X 65 (2.5)
DVCTH-4	100 (4) X 100 (4)
DVCTH-6	150 (6) X 150 (6)
DVCTH-8	203 (8) X 203 (8)
DVCTH-12	305 (12) X 305 (12)

DVCTH-6-P

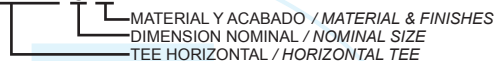

EQUIS HORIZONTAL

No DE CATALOGO CATALOG NUMBER	SECCION DEL DUCTO WIREWAY SECTION
DVCXH-2	65 (2.5) X 65 (2.5)
DVCXH-4	100 (4) X 100 (4)
DVCXH-6	150 (6) X 150 (6)
DVCXH-8	203 (8) X 203 (8)
DVCXH-12	305 (12) X 305 (12)

DVCXH-6-P



HORIZONTAL CROSS

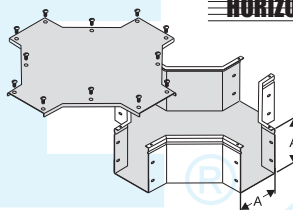

INCLUYE CONECTOR DVCG CON TORNILLERIA
DVCG CONNECTOR AND HARDWARE INCLUDED

CODO VERTICAL EXTERIOR A 90°

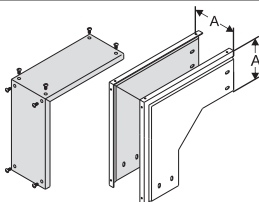

INCLUYE CONECTOR DVCG CON TORNILLERIA
DVCG CONNECTOR AND HARDWARE INCLUDED

90° VERTICAL EXTERNAL ELBOW

No DE CATALOGO CATALOG NUMBER	SECCION DEL DUCTO WIREWAY SECTION
DVCVE-290	65 (2.5) X 65 (2.5)
DVCVE-490	100 (4) X 100 (4)
DVCVE-690	150 (6) X 150 (6)
DVCVE-890	203 (8) X 203 (8)
DVCVE-1290	305 (12) X 305 (12)

DVCVE-690-P

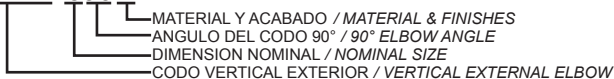

MATERIALES Y ACABADOS:

P : ACERO AL CARBONO / PINTURA ELECTROSTATICA
COLOR GRIS ANSI-49

GE : ACERO AL CARBONO GALVANIZADO ELECTROLITICO
SEGUN ASTM B 633

A : ALUMINIO ACABADO NATURAL

AI : ACERO INOXIDABLE ACABADO NATURAL

TODAS LAS DIMENSIONES EN mm (Pulg) / ALL DIMENSIONS ARE IN mm (Inch)

PUEDE SER SUJETO A MODIFICACION SIN PREVIO AVISO / MAY BE SUBJECT TO MODIFICATION WITHOUT NOTICE

MATERIALS & FINISHES :

P : CARBON STEEL /ELECTROSTATIC
GRAY ENAMEL ANSI 49

GE : ELECTROGALVANIZED STEEL UNDER ASTM B 633

A : NATURAL FINISHED ALUMINUM

AI : NATURAL FINISHED STAINLESS STEEL

CODO VERTICAL EXTERIOR A 45°

No DE CATALOGO CATALOG NUMBER	SECCION DEL DUCTO WIREWAY SECTION
DVCVE-245	65 (2.5) X 65 (2.5)
DVCVE-445	100 (4) X 100 (4)
DVCVE-645	150 (6) X 150 (6)
DVCVE-845	203 (8) X 203 (8)
DVCVE-1245	305 (12) X 305 (12)

DVCVE-645-P

- MATERIAL Y ACABADO / MATERIAL & FINISHES
- ANGULO DEL CODO 45° / 45° ELBOW ANGLE
- DIMENSION NOMINAL / NOMINAL SIZE
- CODO VERTICAL EXTERIOR / VERTICAL EXTERNAL ELBOW

CODO VERTICAL INTERIOR A 90°

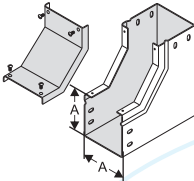

DVCVI-690-P

INCLUYE CONECTOR DVCG CON TORNILLERIA
DVCG CONNECTOR AND HARDWARE INCLUDED

- MATERIAL Y ACABADO / MATERIAL & FINISHES
- ANGULO DEL CODO 90° / 90° ELBOW ANGLE
- DIMENSION NOMINAL / NOMINAL SIZE
- CODO VERTICAL INTERIOR / VERTICAL INTERNAL ELBOW

CODO VERTICAL INTERIOR A 45°

No DE CATALOGO CATALOG NUMBER	SECCION DEL DUCTO WIREWAY SECTION
DVCVI-245	65 (2.5) X 65 (2.5)
DVCVI-445	100 (4) X 100 (4)
DVCVI-645	150 (6) X 150 (6)
DVCVI-845	203 (8) X 203 (8)
DVCVI-1245	305 (12) X 305 (12)

DVCVI-645-P

- MATERIAL Y ACABADO / MATERIAL & FINISHES
- ANGULO DEL CODO 45° / 45° ELBOW ANGLE
- DIMENSION NOMINAL / NOMINAL SIZE
- CODO VERTICAL INTERIOR / VERTICAL INTERNAL ELBOW

45° VERTICAL EXTERNAL ELBOW

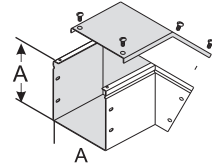

INCLUYE CONECTOR DVCG CON TORNILLERIA
DVCG CONNECTOR AND HARDWARE INCLUDED

90° VERTICAL INTERNAL ELBOW

No DE CATALOGO CATALOG NUMBER	SECCION DEL DUCTO WIREWAY SECTION
DVCVI-290	65 (2.5) X 65 (2.5)
DVCVI-490	100 (4) X 100 (4)
DVCVI-690	150 (6) X 150 (6)
DVCVI-890	203 (8) X 203 (8)
DVCVI-1290	305 (12) X 305 (12)

45° VERTICAL INTERNAL ELBOW

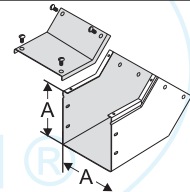

INCLUYE CONECTOR DVCG CON TORNILLERIA
DVCG CONNECTOR AND HARDWARE INCLUDED

TEE VERTICAL

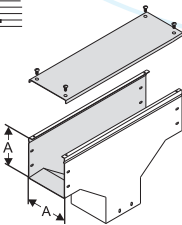

DVCTV-6-P

INCLUYE CONECTOR DVCG CON TORNILLERIA
DVCG CONNECTOR AND HARDWARE INCLUDED

- MATERIAL Y ACABADO / MATERIAL & FINISHES
- DIMENSION NOMINAL / NOMINAL SIZE
- TEE VERTICAL / VERTICAL TEE

VERTICAL TEE

No DE CATALOGO CATALOG NUMBER	SECCION DEL DUCTO WIREWAY SECTION
DVCTV-2	65 (2.5) X 65 (2.5)
DVCTV-4	100 (4) X 100 (4)
DVCTV-6	150 (6) X 150 (6)
DVCTV-8	203 (8) X 203 (8)
DVCTV-12	305 (12) X 305 (12)

MATERIALES Y ACABADOS:

P : ACERO AL CARBONO / PINTURA ELECTROSTATICA
COLOR GRIS ANSI-49

GE : ACERO AL CARBONO GALVANIZADO ELECTROLITICO
SEGUN ASTM B 633

A: ALUMINIO ACABADO NATURAL

AI : ACERO INOXIDABLE ACABADO NATURAL

MATERIALS & FINISHES :

P : CARBON STEEL /ELECTROSTATIC
GRAY ENAMEL ANSI 49

GE : ELECTROGALVANIZED STEEL UNDER ASTM B 633

A: NATURAL FINISHED ALUMINUM

AI : NATURAL FINISHED STAINLESS STEEL

TODAS LAS DIMENSIONES EN mm (Pulg) / ALL DIMENSIONS ARE IN mm (Inch)

PUUEDE SER SUJETO A MODIFICACION SIN PREVIO AVISO / MAY BE SUBJECT TO MODIFICATION WITHOUT NOTICE

SECCION 5.- "UNICANAL"

SISTEMA DE BASTIDORES UNICANAL

¿Requiere en su industria un sistema de soportes rápido de instalar, económico y versátil?

El sistema de soportes UNICANAL fabricado por SOPORTES ELECTRICOS es la solución. Este sistema cuenta con gran versatilidad aumentando su inversión ya que el diseño permite que la instalación se modifique a conveniencia sin necesidad de gastos adicionales.

Con el sistema UNICANAL, las estructuras que tomarían horas en soldarse se arman fácilmente en minutos. Su tuerca de seguridad hace esto posible aun en sitios de difícil acceso ya que no requiere de herramientas especiales. Además el sistema UNICANAL es fácilmente desarmable para transportarlo y ensamblarlo donde se requiera. El sistema es ideal como soporte de tuberías, instalación de sistemas de iluminación, soporte de charolas para cables, mesas de trabajo, etc. El sistema de soportes UNICANAL hace que las demás soluciones parezcan problemas. CONSULETENOS, NUESTRO DEPARTAMENTO TÉCNICO ESTÁ A SUS ORDENES.

CARACTERÍSTICAS Y ESPECIFICACIONES DEL SISTEMA DE BASTIDORES METALICOS "UNICANAL"

Los componentes del sistema de soporte UNICANAL son: el unicanal, la tuerca de seguridad y sus diferentes conectores.

El unicanal es fabricado en acero al carbono, acero inoxidable, fibra de vidrio o aluminio.

Un lado del canal cuenta con una ranura a lo largo con bordes doblados. Estas ranuras sirven para sujetar la tuerca de seguridad y al mismo tiempo sirven de guías para las ranuras de la tuerca UNICANAL.

Las tuercas UNICANAL son fabricadas en acero al carbono; sus extremos redondeados permiten instalarse en cualquier punto a lo largo del UNICANAL y girarse hasta hacer coincidir sus ranuras estriadas con la guía del UNICANAL; el resorte con el que cuenta la tuerca impedirá movimientos de la tuerca quedando lista para el ensamble de los conectores.

Tanto las tuercas como los tornillos cuentan con roscas tipo UNC estandar.

Los conectores son fabricados en acero al carbono, acero inoxidable o aluminio; el espesor de los conectores es de 6.35 mm (1/4") a menos que se especifique lo contrario.

ACABADOS

Todos los componentes del sistema UNICANAL (canal, tuercas y conectores) pueden ser fabricados con los siguientes acabados:

Natural para aluminio y acero inoxidable; Velo Nexus para fibra de vidrio; Galvanizado por inmersión en caliente según ASTM A 123 ; Galvanizado electrolítico según ASTM A 633, Tropicalizado, PVC según NEMA RN 1, o epóxico para acero al carbono. Para acabados especiales consulte a nuestro Departamento Técnico.

COMO SOLICITAR MATERIALES Y ACABADOS

De acuerdo al material y acabado se deberá adicionar un sufijo al número de catálogo mostrado en las paginas de este catálogo; los sufijos serán de acuerdo a lo siguiente:

Acero al carbono galvanizado por inmersión en caliente : **GI**

Acero al carbono galvanizado electrolítico : **GE**

Acero al carbono tropicalizado : **T**

Acero al carbono con recubrimiento de PVC : **PVC**

Acero al carbono acabado epóxico : **PE**

Acero inoxidable acabado natural : **AI**

Aluminio acabado natural : **A**

Fibra de vidrio acabado Nexus : **FV**

Nota : las tuercas solo son fabricadas en acero al carbono galvanizado electrolítico

DIMENSIONES

Las Dimensiones indicadas en el contenido de este catálogo son en milímetros a menos que se especifique lo contrario. Las dimensiones entre paréntesis corresponden a su equivalencia en sistema ingles la cual deberá ser tomada como referencia y no como conversión de unidades.

SOPORTES ELECTRICOS se reserva el derecho de cambiar los diseños y dimensiones sin previo aviso.

METAL UNICANAL FRAMES SYSTEM (STRUT SYSTEM)

Does your company require an economical, flexible and easy to install support system?

The STRUT support system manufactured for SOPORTES ELECTRICOS is the solution. The system cover the strut, lock nut and other accessories which will give you versatility and reducing cost when you need to modify the system.

With STRUT frame system, structures that usually take hours to be soldered, can be easily assembled in a few minutes. Its adjustable lock nut make possible, exact and simple installations, even in the place of most difficult access, this installation does not require special tools.

When you need to transport it, you can do it fast and easily. The system can be used as a pipe support, in the installation of illumination system, in cable tray systems, work benches, etc. STRUT support system makes other solutions look like problems.

CONTACT US, OUR TECHNICAL DEPARTMENT IS READY FOR YOU.

CHARACTERISTICS AND SPECIFICATIONS FOR THE "STRUT" METAL FRAME SYSTEMS

The STRUT metal frame systems part include: The strut, the lock nut and the fittings.

The strut is made of carbon steel, stainless steel, fiber glass reinforced or aluminum.

One side of the channel has a slot that runs all along, this slot is used to fasten the security lock and the same time as a guide for the STRUT lock nuts.

The STRUT lock nuts are made of carbon steel, its rounded edges allow their installation at any point along the slot and can be turned to align the grooves with the strut guides; the spring located in lower side of the nut prevent movements, it will ready to the fitting assembly, each one of the nut and the bolt have unified thread.

The fittings are made of carbon steel, stainless steel or aluminum; unless otherwise specified, the thickness is 6.35 mm (1/4").

FINISHES

All the frames system components could be manufactured with the follow finishes:

Natural for stainless steel and aluminum, Nexus eil for fiber glass reinforced; ASTM A 123 Hot dip galvanized , ASTM B 633 Electro galvanized zinc, Chromium/Zinc coat, NEMA RN 1 PVC coated or Epoxy coat for carbon steel. For another finishes please consult our Technical Department.

HOW SPECIFY MATERIALS AND FINISHES

In accordance with the material and finish, you should put a suffix at the end of the catalog number, this suffix should be according with the follow:

Hot dip galvanized carbon steel : **GI**

Electro galvanized carbon steel : **GE**

Carbon steel Chromium/zinc coated : **T**

Carbon steel PVC coated : **PVC**

Carbon Steel epoxy coated : **PE**

Stainless steel natural finished : **AI**

Aluminum natural finished : **A**

Fiber glass reinforced : **FV**

DIMENSIONS

All dimensions are in millimeters unless otherwise specified. The dimensions in brackets are in english system only for reference.

SOPORTES ELECTRICOS reserve the right to change the designs, dimensions or specifications without notice

While every effort has been made to assure the accuracy of information contained in this catalogs at the time of publication, we can not accept responsibility for inaccuracies resulting from undetected errors or omissions

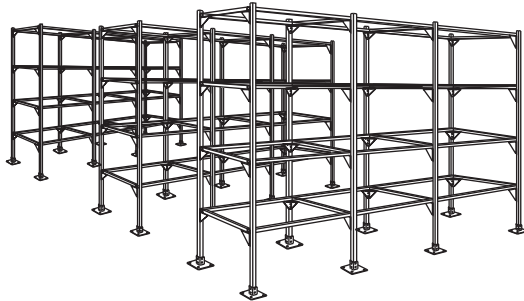

ESTANTERIAS - RACKS AND SHELVING

PALETS / PALETS

MATRICES / DIES

CHAPAS / SHEETS

ROLLOS DE CABLES / CABLE ROLLS

MATERIALES DE PRODUCCION / PRODUCTION MATERIALS

PIEZAS AUTOMOTRICES / AUTOMOTIVE PARTS

ALMACEN GENERAL / GENERAL STORE

BARRAS / BARS

BARRILES / TANKS

MUEBLES / FURNITURE STORE

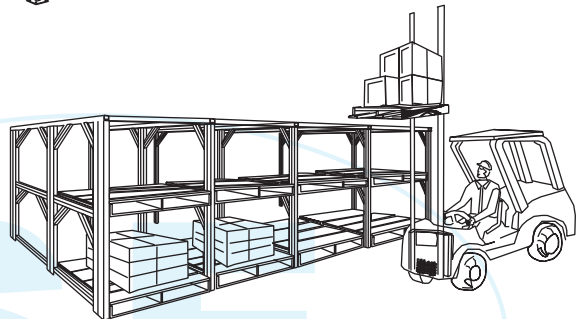

CANCELES MOVILES - MODULATE WALLS

DE PISO A TECHO / FLOOR TO CEILING

ALTURA DE PUERTA / DOOR HEIGHT

RIELES PULIDOS / POLISHED RAILS

RIELES COMUNES / STANDARD RAILS

DEPOSITO DE HERAMIENTAS / TOOL STORAGE

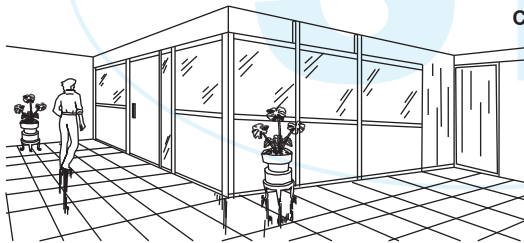

DESPACHOS DE OFICINAS / OFFICES

LUGAR DE ESTUDIO / STUDIES

SEPARADOR DE CUARTOS / ROOM DIVISIONS

PARADES PARA LABORATORIOS / LABORATORY WALLS

SOPORTE DE PANELES DIVISORIOS / DIVISION SUPPORTS



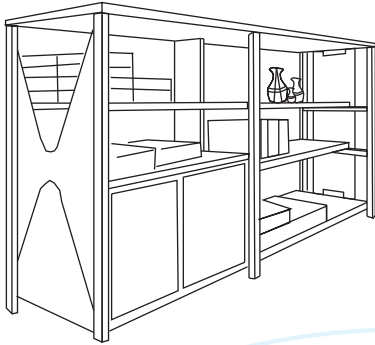

VITRINAS - SHOW CASE

VITRINAS DE VENTANA / *SHOW WINDOWS*
 VITRINAS PARA MERCADERIA / *SHOP WINDOWS*



SEPARADORES DE VITRINAS / *SHOWCASE DIVISIONS*
 EXHIBICIONES INDUSTRIALES / *INDUSTRIAL EXHIBITIONS*
 PAREDES DE EXHIBICIONES / *EXHIBITION WALLS*

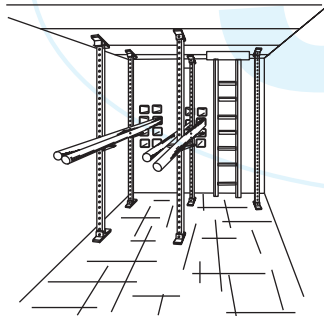

APLICACIONES ESPECIALES - SPECIAL APLICATIONS

INSTRUMENTOS / *INSTRUMENTS*
 BASTIDORES DE TRANSPORTE / *TRANSPORTATION RACKS*
 ESTANTERIA / *STANDARD RACKS*
 BASTIDOR DE HORNO / *OVEN RACKS*
 SOPORTE DE RAYOS X / *X RAY SUPPORT*
 CASSETAS PARA SOLDADORES / *WELDING HOUSEHOLDS*

ARMADO DE ESCENARIOS / *STAGE RACKS*
 MUELLES DE EMBARCACIONES / *DOCKS*
 CAJAS DE CABLES / *JUNCTION CABLE BOXES*
 ENTREPIOS / *ENTRESOLS*
 ESCALERAS / *STAIRS*
 ESCALERAS PARA INCENDIOS / *FIRE STAIRS*
 TOLDOS / *AWNINGS, VANITY TENT*

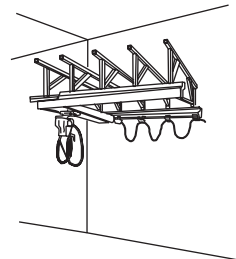

SOPORTES ELECTRICOS - ELECTRICAL SUPPORTS

CONDUCTOS / WIREWAY

BARRA DE CONDUCCION / ELECTRICAL BAR

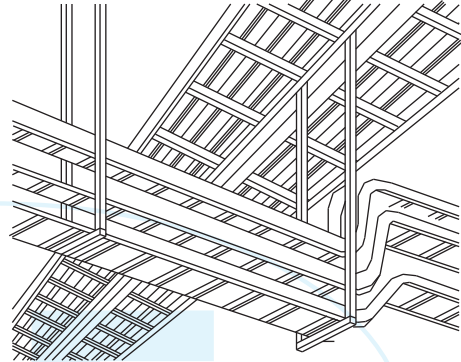
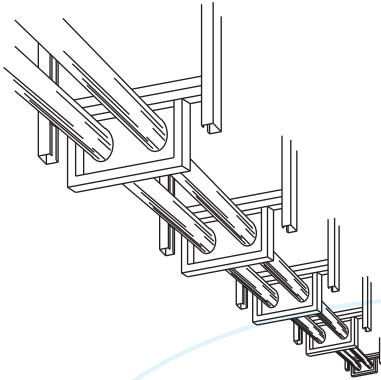

SOPORTES PARA CABLES / CABLE TRAY SUPPORT

EQUIPO ELECTRICOS / ELECTRICAL EQUIPMENT

SOPORTES PARA TUBERIA CONDUIT / CONDUIT SUPPORT

SOPORTES PARA ALUMBRADO - LIGHTING SUPPORT

EQUIPO FLUORESCENTE / FLUORESCENT LIGHTING

REFLECTORES / FLOODLIGHTS

VITRINAS / SHOW WINDOWS LIGHT

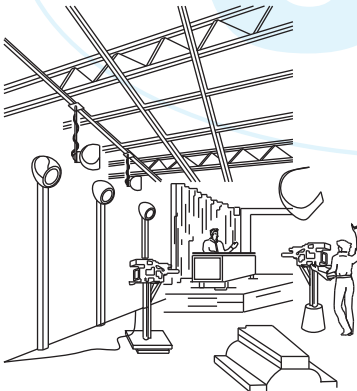

ALUMBRADO DE ESTUDIOS / STAGE LIGHTING

CIELORASOS LUMINOSOS / CEILING LIGHTING

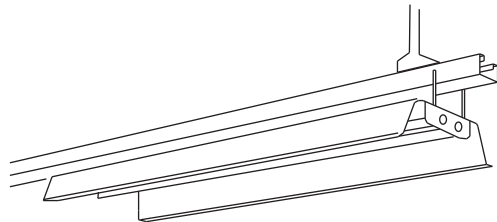

SOPORTES MECANICOS - MECHANICAL APPLICATIONS

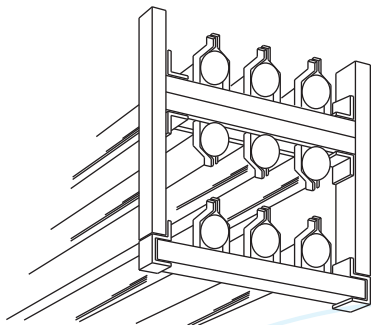

CAÑERIAS PARA AGUA / PIPING RAKS

PUNTALES PARA TUNELES / TUNNEL PIPE STANCHIONS

CONDUCCION DE / SANITARY PIPES SUPPORT
INSTALACIONES SANITARIAS

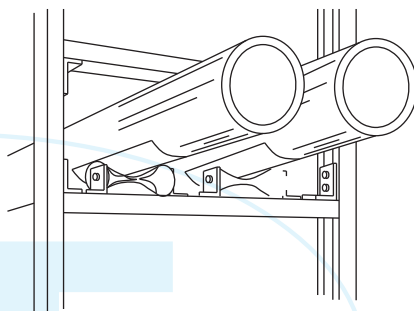

TUBERIAS DE VAPOR / VAPOR PIPES

TUBERIAS / STANDARD PIPES

SUJECION DE TUBERIA A DUCTOS / PIPE TO DUCT CLAMPS

SOPORTES ESTRUCTURALES - STRUCTURAL SUPPORTS

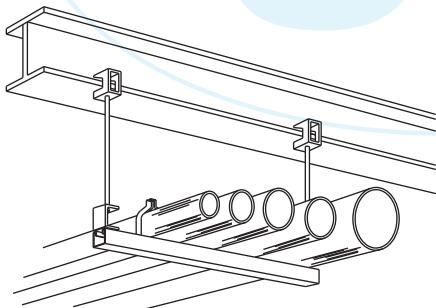

INSERTOS DE CONCRETO / CONCRETE INSERTS

INSERTOS PARA PARED / CANTILEVER INSERTS

SOPORTE PARA VIGAS / BEAM ATTACHMENTS

TRAPECIOS / TRAPEZE HANGERS

PAREDES DE CORTINAS / WALL FRAMING

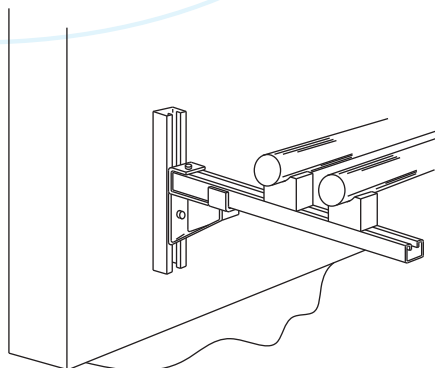



Nosotros Ponemos el Sistema y Usted la Idea... We Put the System You the Imagination...

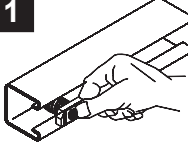

Presenta las exclusivas conexiones tipo UNICANAL
Sin Soldadura
Sin Taladro
100% Ajustables
100% Reusables

Present our exclusively type STRUT fittings
No Welding
No Drilling
Fully Adjustable
Fully Reusable

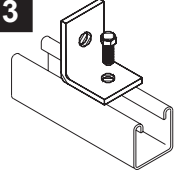
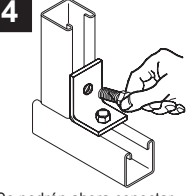
<p>1</p>  <p>Inserte la tuerca para riel en cualquier lugar a lo largo de la ranura del riel acanalado. Los extremos redondeados de la tuerca permiten su fácil inserción.</p> <p><i>Insert the spring nut anywhere along continuous slotted strut. Designed for easy insertion and self-alignment.</i></p>	<p>2</p>  <p>Al girar la tuerca a 90° hacia la derecha, las ranuras de esta se alinean con los bordes internos del riel. Las piezas de montaje podrán colocarse en cualquier lugar en la abertura del riel.</p> <p><i>A 90 clockwise turn aligns the grooves in the nut with the interned edges of the strut.</i></p>	<p>3</p>  <p>Inserte el perno a través de la placa de conexión y rosquelo a la tuerca con resorte.</p> <p><i>Position fitting over strut nut and insert bolt to start any conection.</i></p>	<p>4</p>  <p>Se podrán ahora conectar secciones adicionales de riel a la pieza ya montada siguiendo los procedimientos que se describen en los pasos 1-3.</p> <p><i>Now you can conect additional strut following steps 1 - 3.</i></p>
---	---	--	---

La conexión UNICANAL...
Es fuerte, rápida, económica ajustable para todos los usos de bastidores y hace que todas las uniones sean estándar

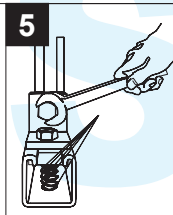

Al apretar la tuerca con una llave, los dientes estriados de la tuerca muerden los bordes de la ranura del riel formando una fuerte conexión.

With the twist of a wrench, strut nut looks its teeth firmly against inturned lips.

The STRUT system is strong, fast, cheap, able to all frames applications, make all the unions standards

Riel acanalado de características especiales, permite la sujeción de variados elementos de fijación sin tener que perforar o soldar.
La regulación puede ser infinita a lo largo del riel acanalado

Special characteristics strut, its able to support any fitting without welding nor drilling. The number and positions of the fittings could be unlimited along of the strut.

El tornillo hexagonal se rosca fácilmente en la tuerca con resorte conectando la placa de conexión al canal fácilmente

The hex bolt is easily assambled in the spring nut joint the fitting with the strut

Las placas de conexión permiten la construcción de estructuras de soporte de las mas diversas formas, tamaños y para múltiples aplicaciones

With fittings you can construct strut support in a wide size, forms and applications

Las tuercas de fijación están diseñadas para funcionar específicamente en el riel acanalado. Su forma permite una instalación cómoda y rápida, el resorte permite fijarla en un punto determinado

The nuts are designed for channel, this design provide a quickly instalation. the spring provide and easy localization of the fittings

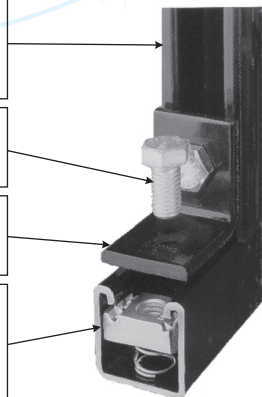

SECCION 5.1.- TRAMOS RECTOS "UNICANAL"

SECCION 5.1.- STRAIGHT SECTION "STRUT"

UNICANAL LU-1000 Y COMBINACIONES
LU-1000 STRUT AND COMBINATIONS

NUMERO DE CATALOGO CATALOG NUMBER	PROFUNDIDAD DEPTH
	A mm (Pulg)
LU-1000	41.3 (1.625)
LU-1001	82.6 (3.250)

LONGITUD :1.00m(3.28') Y 3.00 m
 ESPESOR : CALIBRE 12
 LENGHT :1.00m(3.28') AND 3.00 m
 THICKNESS : 12

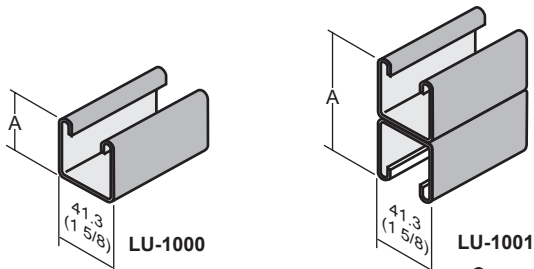

UNICANAL LU-2000 Y COMBINACIONES
LU-2000 STRUT AND COMBINATIONS

NUMERO DE CATALOGO CATALOG NUMBER	PROFUNDIDAD DEPTH
	A mm (Pulg)
LU-2000	41.3 (1.625)
LU-2001	82.6 (3.250)

LONGITUD :1.00m(3.28') Y 3.00 m
 ESPESOR : CALIBRE 14, 16 y 18
 LENGHT :1.00m(3.28') AND 3.00 m
 THICKNESS : 14, 16 Y 18

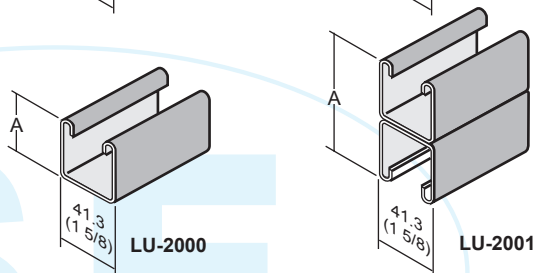

UNICANAL LU-3300 Y COMBINACIONES
LU-3300 STRUT AND COMBINATIONS

NUMERO DE CATALOGO CATALOG NUMBER	PROFUNDIDAD DEPTH
	A mm (Pulg)
LU-3300	20.6 (0.812)
LU-3301	41.3 (1.625)

LONGITUD :1.00m(3.28') Y 3.00 m
 ESPESOR : CALIBRE 12
 LENGHT :1.00m(3.28') AND 3.00 m
 THICKNESS : 12

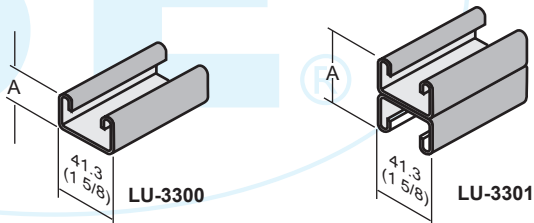

UNICANAL LU-4000 Y COMBINACIONES
LU-4000 STRUT AND COMBINATIONS

NUMERO DE CATALOGO CATALOG NUMBER	PROFUNDIDAD DEPTH
	A mm (Pulg)
LU-4000	20.6 (0.812)
LU-4001	41.3 (1.625)

LONGITUD :1.00m(3.28') Y 3.00 m
 ESPESOR : CALIBRE 14, 16 y 18
 LENGHT :1.00m(3.28') AND 3.00 m
 THICKNESS : 14, 16, 18

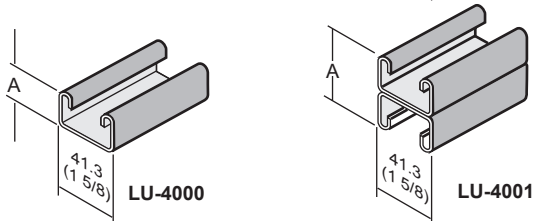

MATERIAL: LAMINA DE ACERO AL CARBONO
 ACABADO: GALVANIZADO ELECTROLITICO(USO INTERIOR Y USO EXTERIOR C/BAJA HUMEDAD),
 GALVANIZADO INMERSION EN CALIENTE (PARA USO INTERIOR Y EXTERIOR).
 MATERIAL: CARBON STEEL SHEET
 FINISHES: ELECTROGALVANIZED ZINC, HOT-DIP GALVANIZED

PUEDEN SER SUJETOS A MODIFICACION SIN PREVIO AVISO / MAYBE SUBJECT TO MODIFICATION WITHOUT NOTICE

TRAMOS RECTOS "UNICANAL"

STRUT STRAIGHT SECTION

UNICANAL LU-5500 Y COMBINACIONES
LU-5500 STRUT AND COMBINATIONS

NUMERO DE CATALOGO CATALOG NUMBER	PROFUNDIDAD DEPTH A
	mm (Pulg)
LU-5500	61.9 (2.437)
LU-5501	123.8 (4.875)

LONGITUD : 1.00m(3.28') Y 3.00 m
ESPESOR : CALIBRE 12
LENGHT : 1.00m(3.28') AND 3.00 m
THICKNESS : 12

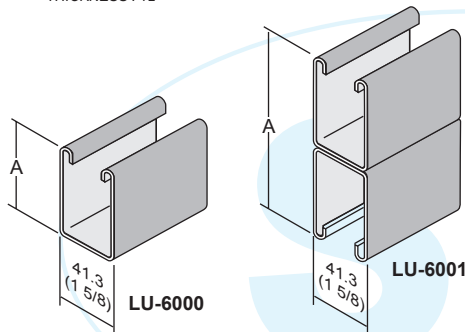
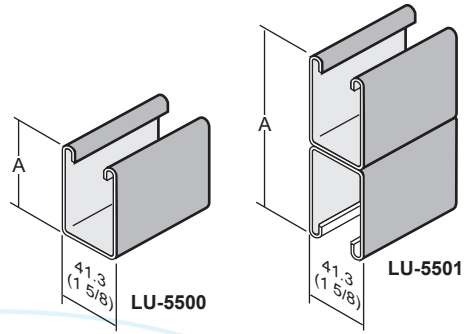

UNICANAL LU-6000 Y COMBINACIONES
LU-6000 STRUT AND COMBINATIONS

NUMERO DE CATALOGO CATALOG NUMBER	PROFUNDIDAD DEPTH A
	mm (Pulg)
LU-6000	61.9 (2.437)
LU-6001	123.8 (4.875)

LONGITUD : 1.00m(3.28') Y 3.00 m
ESPESOR : CALIBRE 14
LENGHT : 1.00m(3.28') AND 3.00 m
THICKNESS : 14

MATERIAL: LAMINA DE ACERO AL CARBONO
ACABADO: GALVANIZADO ELECTROLITICO(USO INTERIOR Y USO EXTERIOR C/BAJA HUMEDAD), GALVANIZADO INMERSION EN CALIENTE (PARA USO INTERIOR Y EXTERIOR).
MATERIAL: CARBON STEEL SHEET
FINISHES: ELECTROGALVANIZED ZINC, HOT-DIP GALVANIZED

UNICANAL LU-7000 Y COMBINACIONES
LU-6000 STRUT AND COMBINATIONS

NUMERO DE CATALOGO CATALOG NUMBER	PROFUNDIDAD DEPTH A
	mm (Pulg)
LU-7000	81.9 (3.224)

LONGITUD : 1.00m(3.28') Y 3.00 m
ESPESOR : CALIBRE 12
LENGHT : 1.00m(3.28') AND 3.00 m
THICKNESS : 12

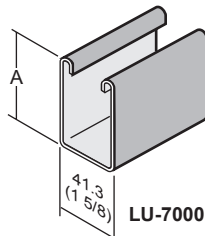

UNICANAL LU-7000 Y COMBINACIONES
LU-6000 STRUT AND COMBINATIONS

NUMERO DE CATALOGO CATALOG NUMBER	PROFUNDIDAD DEPTH A
	mm (Pulg)
LU-8000	81.9 (3.224)

LONGITUD : 1.00m(3.28') Y 3.00 m
ESPESOR : CALIBRE 14
LENGHT : 1.00m(3.28') AND 3.00 m
THICKNESS : 14

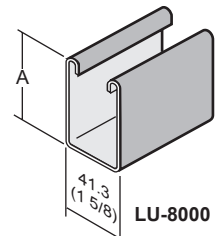

NO DISPONIBLE EN PERFORADO / NOT AVAILABLE IN PERFORATED
PUEDE SER SUJETO A MODIFICACION SIN PREVIO AVISO / MAYBE SUBJECT TO MODIFICATION WITHOUT NOTICE

TRAMOS RECTOS "UNICANAL"

STRUT STRAIGHT SECTION

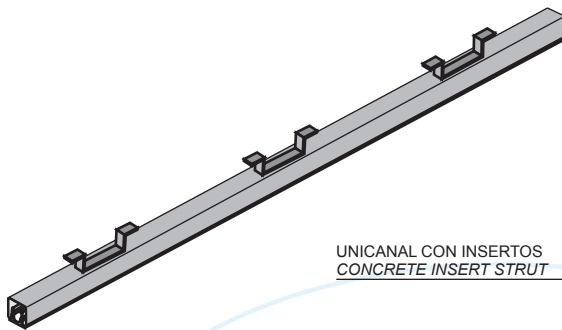

UNICANAL CON INSERTOS
CONCRETE INSERT STRUT

TIRA DE PLASTICO PARA CERRAR EL CANAL
PLASTIC CLOSURE STRIP

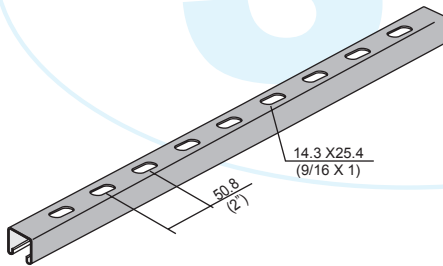
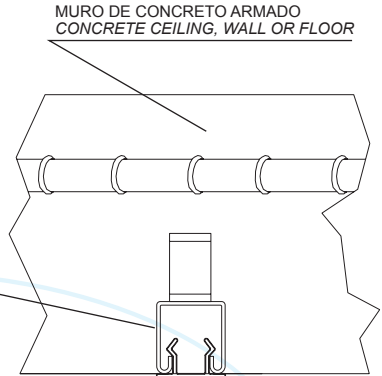

PSLU-

UNICANAL PERFORADO TIPO SLOT.
APLICABLE EN LOS CANALES :
LU-1000, LU-2000, LU-3300
LU-4000, LU-5500, LU-6000
LU-7000, LU-8000

SLOTTED STRUT
AVAILABLE IN STRUT
LU-1000, LU-2000, LU-3300
LU-4000, LU-5500, LU-6000
LU-7000, LU-8000

PARA OTRAS CONFIGURACIONES DE PERFORADO
CONSULTE NUESTRO DEPARTAMENTO TECNICO

FOR ANOTHER PATTERNS CONSULT
OUR TECHNICAL DEPARTMENT

MATERIAL: LAMINA DE ACERO AL CARBONO
ACABADO: GALVANIZADO ELECTROLITICO(USO INTERIOR Y USO EXTERIOR C/BAJA HUMEDAD),
GALVANIZADO INMERSION EN CALIENTE (PARA USO INTERIOR Y EXTERIOR).
MATERIAL: CARBON STEEL SHEET
FINISHES: ELECTROGALVANIZED ZINC, HOT-DIP GALVANIZED

PUEDO SER SUJETO A MODIFICACION SIN PREVIO AVISO / MAYBE SUBJECT TO MODIFICATION WITHOUT NOTICE

SECCION 5.2 ACCESORIOS PARA ENSAMBLE DE UNICANAL

SECTION 1.2 STRUT FITTINGS

CONEXIONES DE CHAPA PLANA

FLAT PLATE FITTINGS

PARA UNICANAL

FOR STRUT

ROLDANA CUADRADA SQUARE WHASHER

NUMERO DE CATALOGO	DIAMETRO ORIFICIO A MM (PULG)	DIAMETRO TORNILLO MM (PULG)
LU-1062	9.5 (0.375")	7.9 (0.312")
LU-1063	11.1 (0.437")	9.5 (0.375")
LU-1064	14.3 (0.562")	12.7 (0.500")

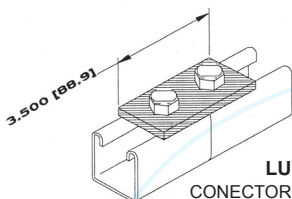
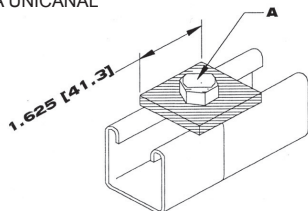

LU-1065
CONECTOR DE EMPALME
2 ORIFICIOS
TWO HOLES SPLICE PLATE

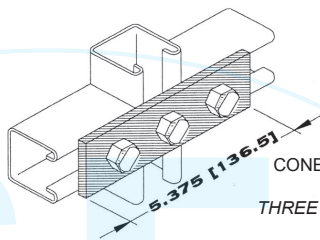

LU-1066
CONECTOR DE EMPALME
3 ORIFICIOS
THREE HOLES SPLICE PLATE

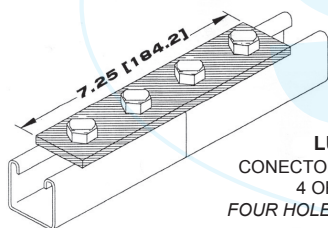

LU-1067
CONECTOR DE EMPALME
4 ORIFICIOS
FOUR HOLES SPLICE PLATE

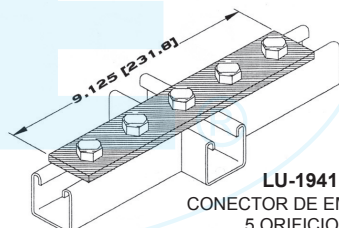

LU-1941
CONECTOR DE EMPALME
5 ORIFICIOS
FIVE HOLES SPLICE PLATE

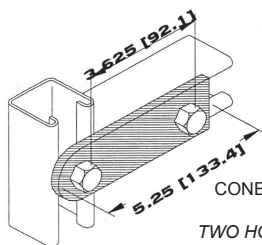

LU-2325
CONECTOR GIRATORIO
2 ORIFICIOS
TWO HOLES SWIVEL PLATE

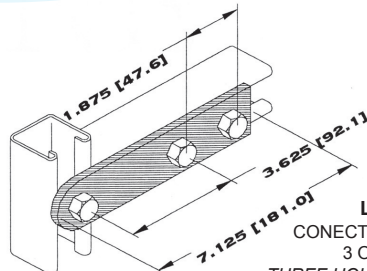

LU-2324
CONECTOR GIRATORIO
3 ORIFICIOS
THREE HOLES SWIVEL PLATE

ESPECIFICACIONES (SPECIFICATIONS)

DIAMETRO DE ORIFICIO (HOLE SIZE): 14.3 (0,562)

ESPACIAMIENTO DEL CENTRO DE ORIFICIO EXTREMO (HOLE SPACING): 20.6(0,812)

ESPACIAMIENTO ENTRE CENTROS DE ORIFICIO (HOLE SPACING): 47.6(1,875)

MATERIAL: ACERO AL CARBONO (STRIP STEEL) ANCHO: 41.3(1,625)

ACABADO: GALVANIZADO ELECTROLITICO. GALVANIZADO POR INMERSION EN CALIENTE

FINISHES: ELECTROLYTIC GALVANIZED, HOT-DIP GALVANIZED

DIMENSIONES EN PULG. (MM) / DIMENSIONS ARE IN mm (Inch)

PUEDE SER SUJETO A MODIFICACION SIN PREVIO AVISO / MAY BE SUBJECT TO MODIFICATION WITHOUT NOTICE

CONEXIONES DE CHAPA PLANA

PARA UNICANAL

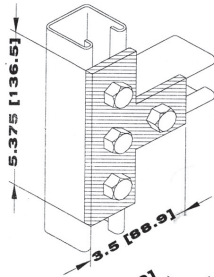

LU-1031
CONECTOR "T"
4 ORIFICIOS
FOUR HOLE TEE PLATE

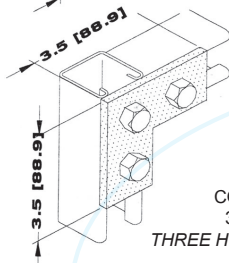

LU-1036
CONECTOR "L"
3 ORIFICIOS
THREE HOLE CORNER PLATE

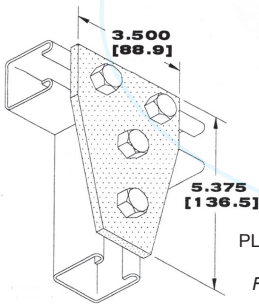

LU-1358
PLACA CONECTORA
4 ORIFICIOS
FOUR HOLE TEE
GUSSET PLATE

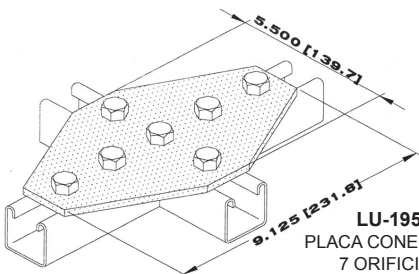

LU-1950
PLACA CONECTORA
7 ORIFICIOS
SEVEN HOLE CROSS
GUSSET PLATE

FLAT PLATE FITTINGS

FOR STRUT

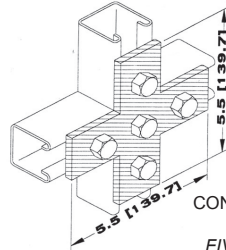

LU-1028
CONECTOR DE CRUZ
5 ORIFICIOS
FIVE HOLE CROSS
PLATE

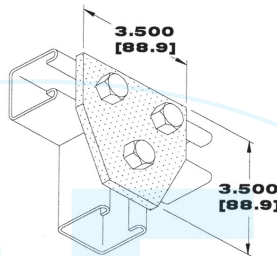

LU-1356
PLACA CONECTORA
3 ORIFICIOS
THREE HOLE GUSSET PLATE

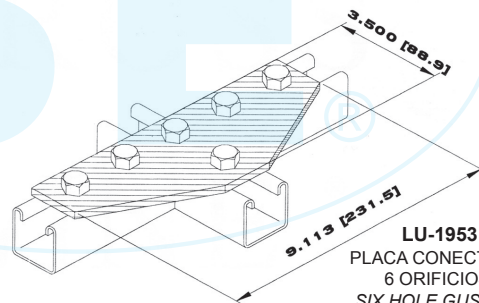

LU-1953
PLACA CONECTORA
6 ORIFICIOS
SIX HOLE GUSSET
PLATE

ESPECIFICACIONES (SPECIFICATIONS)

DIAMETRO DE ORIFICIO (HOLE SIZE): 14.3 (0,562)

ESPACIAMIENTO DEL CENTRO DE ORIFICIO AL

EXTREMO (HOLE SPACING): 20.6(0,812)

ESPACIAMIENTO ENTRE CENTRO

DE ORIFICIOS (HOLE SPACING): 47.6(1,875)

MATERIAL: ACERO AL CARBONO (STRIP STEEL)

ANCHO: 41.3(1,625)

ACABADO: GALVANIZADO ELECTROLITICO.

GALVANIZADO POR INMERSION EN CALIENTE

FINISHES: ELECTROLYTIC GALVANIZED, HOT-DIP

GALVANIZED

DIMENSIONES EN PULG. (MM)

DIMENSIONS ARE IN mm (Inch)

PUUEE SER SUJETO A MODIFICACION SIN PREVIO AVISO

MAY BE SUBJECT TO MODIFICATION WITHOUT NOTICE

CONEXIONES EN FORMA DE "U"

PARA UNICANAL

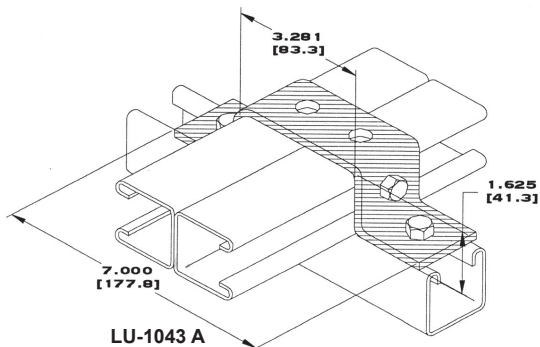

LU-1043 A
CONECTOR "U"
6 ORIFICIOS
SIX HOLE SUPPORT

"U" FITTINGS

FOR STRUT

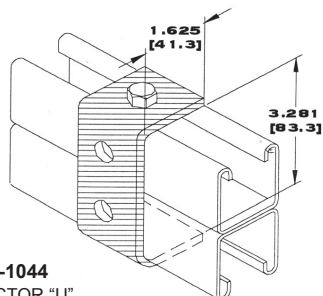

LU-1044
CONECTOR "U"
4 ORIFICIOS
FOUR HOLE CLEVIS

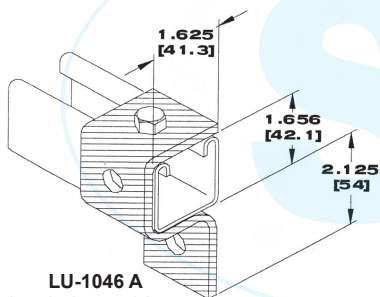

LU-1046 A
CONECTOR DE COPA
3 ORIFICIOS
THREE HOLE CUP SUPPORT

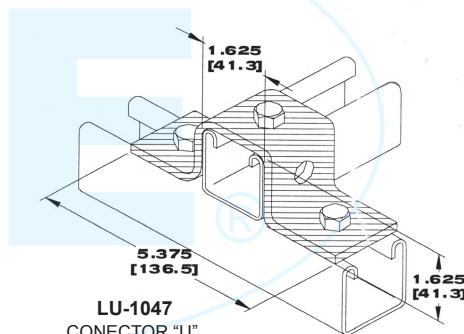

LU-1047
CONECTOR "U"
5 ORIFICIOS
FIVE HOLE "U" SUPPORT

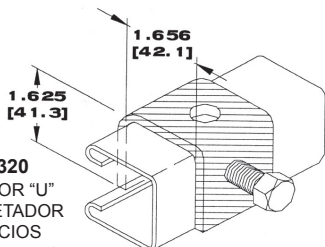

LU-1320
CONECTOR "U"
CON SUJETADOR
2 ORIFICIOS
ONE STUD RING
CONNECTION

ESPECIFICACIONES (SPECIFICATIONS)

DIAMETRO DE ORIFICIO (HOLE SIZE): 14.3 (0,562)

ESPACIAMIENTO DEL CENTRO DE ORIFICIO AL EXTREMO (HOLE SPACING): 20.6(0,812)

ESPACIAMIENTO ENTRE CENTRO DE ORIFICIOS (HOLE SPACING): 47.6(1,875)

MATERIAL: ACERO AL CARBONO (STRIP STEEL)
ANCHO: 41.3(1,625)

ACABADO: GALVANIZADO ELECTROLITICO.
GALVANIZADO POR INMERSION EN CALIENTE
FINISHES: ELECTROLYTIC GALVANIZED, HOT-DIP GALVANIZED

DIMENSIONES EN PULG. (MM)

DIMENSIONS ARE IN mm (Inch)

PUEDO SER SUJETO A MODIFICACION SIN PREVIO AVISO
MAY BE SUBJECT TO MODIFICATION WITHOUT NOTICE

CONEXIONES EN FORMA DE "U"

PARA UNICANAL

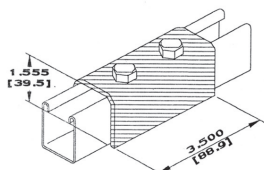

LU-1376
CONECTOR
DE HORQUILLA
2 ORIFICIOS
TWO HOLE SPLICE CLEVIS

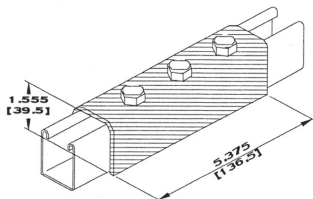

LU-1376A
CONECTOR
DE HORQUILLA
3 ORIFICIOS
THREE HOLE SPLICE CLEVIS

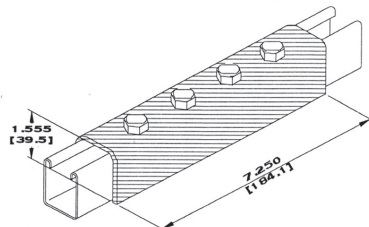

LU-1377
CONECTOR
DE HORQUILLA
4 ORIFICIOS
FOUR HOLE SPLICE CLEVIS

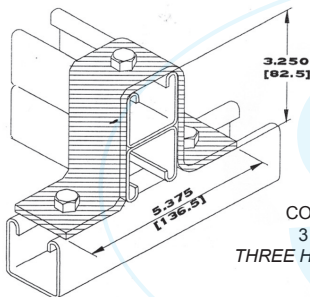

LU-1737
CONECTOR "U"
3 ORIFICIOS
THREE HOLE "U" SUPPORT

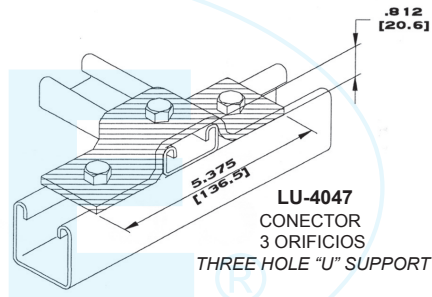

LU-4047
CONECTOR
3 ORIFICIOS
THREE HOLE "U" SUPPORT

CONEXIONES EN FORMA DE "Z"

PARA UNICANAL

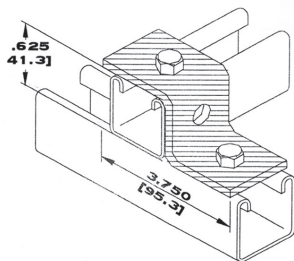

LU-1045
CONECTOR "Z"
3 ORIFICIOS
THREE HOLE "Z" SUPPORT

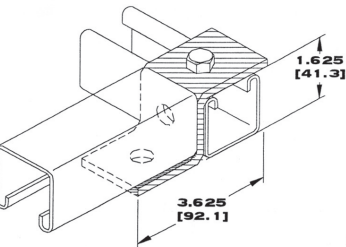

"Z" FITTINGS

FOR STRUT

ESPECIFICACIONES (SPECIFICATIONS)

DIAMETRO DE ORIFICIO (HOLE SIZE): 14.3 (0,562)

ESPACIAMIENTO DEL CENTRO DE ORIFICIO EXTREMO (HOLE SPACING): 20.6(0,812)

ESPACIAMIENTO ENTRE CENTRO DE ORIFICIOS (HOLE SPACING): 47.6(1,875)

MATERIAL: ACERO AL CARBONO (STRIP STEEL) ANCHO: 41.3(1,625)

ACABADO: GALVANIZADO ELECTROLITICO. GALVANIZADO POR INMERSION EN CALIENTE

FINISHES: ELECTROLYTIC GALVANIZED, HOT-DIP GALVANIZED

DIMENSIONES EN PULG. (MM) / DIMENSIONS ARE IN mm (Inch)

PUEDEN SER SUJETOS A MODIFICACION SIN PREVIO AVISO / MAY BE SUBJECT TO MODIFICATION WITHOUT NOTICE

CONEXIONES EN FORMA DE "Z"

PARA UNICANAL

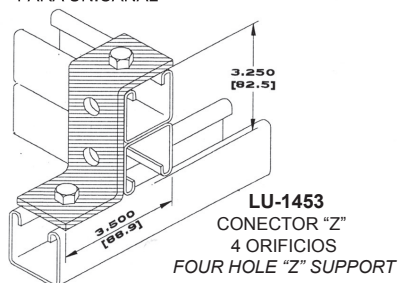

"Z" FITTINGS

FOR STRUT

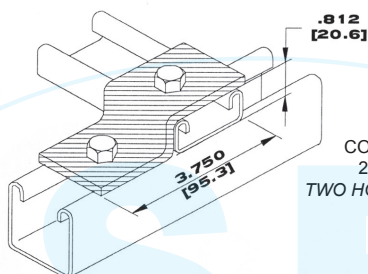
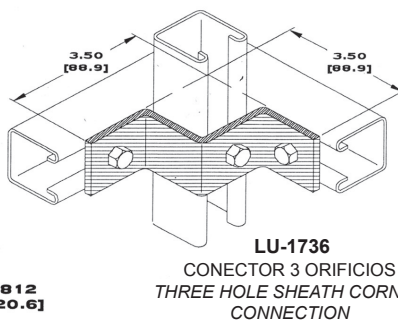

CONEXIONES ANGULARES A 90°

PARA UNICANAL

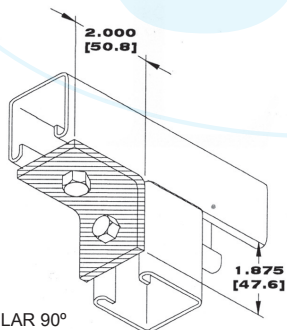

90° ANGULAR FITTINGS

FOR STRUT

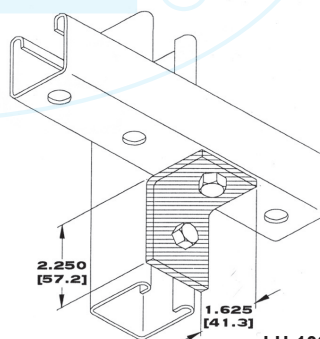

ESPECIFICACIONES (SPECIFICATIONS)

DIAMETRO DE ORIFICIO (HOLE SIZE): 14.3 (0,562)
 ESPACIAMIENTO DEL CENTRO DE ORIFICIO EXTREMO (HOLE SPACING): 20.6(0,812)
 ESPACIAMIENTO ENTRE CENTRO DE ORIFICIOS (HOLE SPACING): 47.6(1,875)
 MATERIAL: ACERO AL CARBONO (STRIP STEEL) ANCHO: 41.3(1,625)
 ACABADO: GALVANIZADO ELECTROLITICO. GALVANIZADO POR INMERSION EN CALIENTE
 FINISHES: ELECTROLYTIC GALVANIZED, HOT-DIP GALVANIZED

DIMENSIONES EN PULG. (MM) / DIMENSIONS ARE IN mm (Inch)

PUEDE SER SUJETO A MODIFICACION SIN PREVIO AVISO / MAY BE SUBJECT TO MODIFICATION WITHOUT NOTICE

CONEXIONES ANGULARES DE 90°

PARA UNICANAL

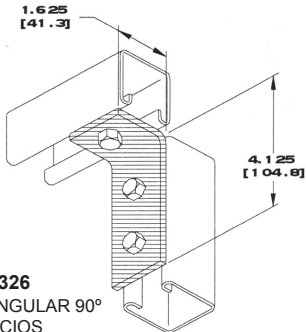

LU-1326
 CONECTOR ANGULAR 90°
 3 ORIFICIOS
 THREE HOLE CORNER ANGLE

90° ANGULAR FITTINGS

FOR STRUT

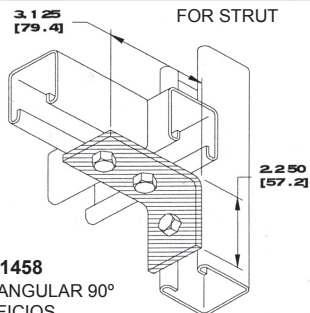

LU-1458
 CONECTOR ANGULAR 90°
 3 ORIFICIOS
 THREE HOLE CORNER ANGLE

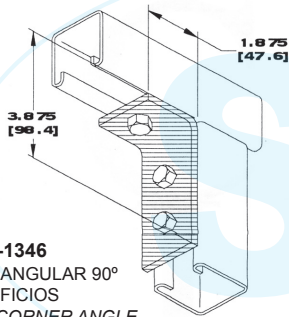

LU-1346
 CONECTOR ANGULAR 90°
 3 ORIFICIOS
 THREE HOLE CORNER ANGLE

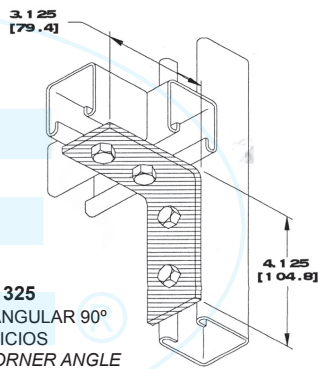

LU-1325
 CONECTOR ANGULAR 90°
 4 ORIFICIOS
 FOUR HOLE CORNER ANGLE

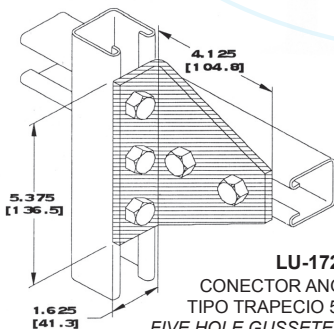

LU-1728
 CONECTOR ANGULAR 90°
 TIPO TRAPEZIO 5 ORIFICIOS
 FIVE HOLE GUSSETED SHELF ANGLE

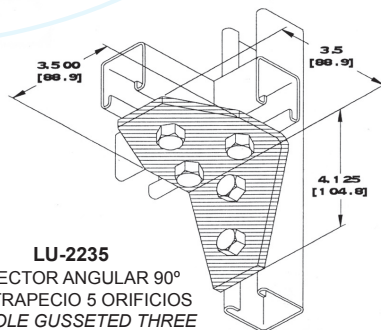

LU-2235
 CONECTOR ANGULAR 90°
 TIPO TRAPEZIO 5 ORIFICIOS
 FIVE HOLE GUSSETED THREE
 WAY SHELF ANGLE

ESPECIFICACIONES (SPECIFICATIONS)

DIAMETRO DE ORIFICIO (HOLE SIZE): 14.3 (0.562)

ESPACIAMIENTO DEL CENTRO DE ORIFICIO EXTREMO (HOLE SPACING): 20.6(0,812)

ESPACIAMIENTO ENTRE CENTRO DE ORIFICIOS (HOLE SPACING): 47.6(1,875)

MATERIAL: ACERO AL CARBONO (STRIP STEEL) ANCHO: 41.3(1,625)

ACABADO: GALVANIZADO ELECTROLITICO. GALVANIZADO POR INMERSION EN CALIENTE

FINISHES: ELECTROLYTIC GALVANIZED, HOT-DIP GALVANIZED

DIMENSIONES EN PULG. (MM) / DIMENSIONS ARE IN mm (Inch)

PUEDEN SER SUJETOS A MODIFICACION SIN PREVIO AVISO / MAY BE SUBJECT TO MODIFICATION WITHOUT NOTICE

CONEXIONES ANGULARES DE 90°

PARA UNICANAL

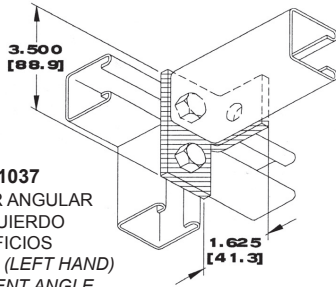

LU-1037
 CONECTOR ANGULAR
 90° IZQUIERDO
 3 ORIFICIOS
 THREE HOLE (LEFT HAND)
 OFFSET BENT ANGLE

90° ANGULAR FITTINGS

FOR STRUT

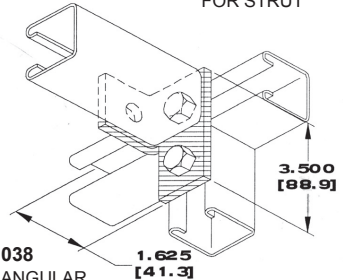

LU-1038
 CONECTOR ANGULAR
 90° DERECHO 3 ORIFICIOS
 THREE HOLE (RIGHT HAND)
 OFFSET BENT ANGLE

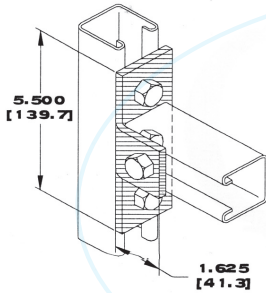

LU-1821
 CONECTOR "T"
 ANGULAR 90°
 DERECHO 4 ORIFICIOS
 FOUR HOLE (RIGHT HAND)
 OFFSET BENT TEE

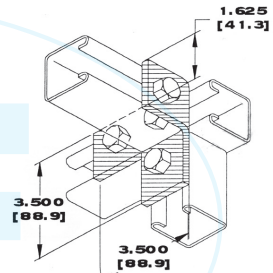

LU-1034
 CONECTOR "T" ANGULAR 90°
 IZQUIERDO 4 ORIFICIOS
 FOUR HOLE (LEFT HAND)
 OFFSET BENT TEE

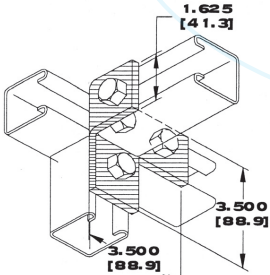

LU-1035
 CONECTOR "T" ANGULAR 90°
 DERECHO 4 ORIFICIOS
 FOUR HOLE (RIGHT HAND)
 OFFSET BENT TEE

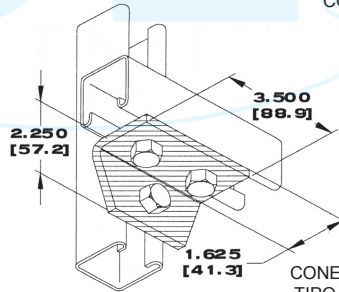

LU-1357
 CONECTOR "T" ANGULAR 90°
 TIPO TRAPECIO 3 ORIFICIOS
 THREE HOLE GUSSETED SHELF ANGLE

ESPECIFICACIONES (SPECIFICATIONS)

DIAMETRO DE ORIFICIO (HOLE SIZE): 14.3 (0,562)

ESPACIAMIENTO DEL CENTRO DE ORIFICIO EXTREMO (HOLE SPACING): 20.6(0,812)

ESPACIAMIENTO ENTRE CENTRO DE ORIFICIOS (HOLE SPACING): 47.6(1,875)

MATERIAL: ACERO AL CARBONO (STRIP STEEL) ANCHO: 41.3(1,625)

ACABADO: GALVANIZADO ELECTROLITICO. GALVANIZADO POR INMERSION EN CALIENTE

FINISHES: ELECTROLYTIC GALVANIZED, HOT-DIP GALVANIZED

DIMENSIONES EN PULG. (MM) / DIMENSIONS ARE IN mm (Inch)

PUEDE SER SUJETO A MODIFICACION SIN PREVIO AVISO / MAY BE SUBJECT TO MODIFICATION WITHOUT NOTICE

CONEXIONES ANGULARES DE 90°

PARA UNICANAL

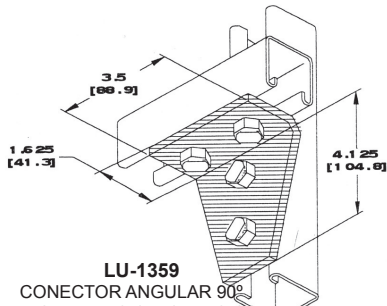

LU-1359
 CONECTOR ANGULAR 90°
 TIPO TRAPEZIO 4 ORIFICIOS
 FOUR HOLE GUSSETED SHELF ANGLE

90° ANGULAR FITTINGS

FOR STRUT

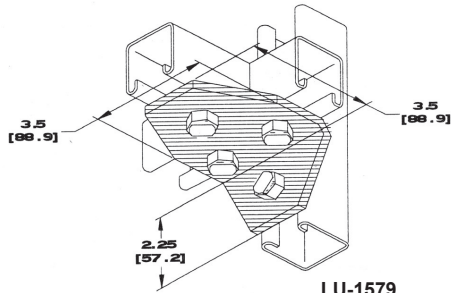

LU-1579
 CONECTOR ANGULAR 90°
 TIPO TRAPEZIO 4 ORIFICIOS
 FOUR HOLE GUSSETED THREE
 WAY SHELF ANGLE

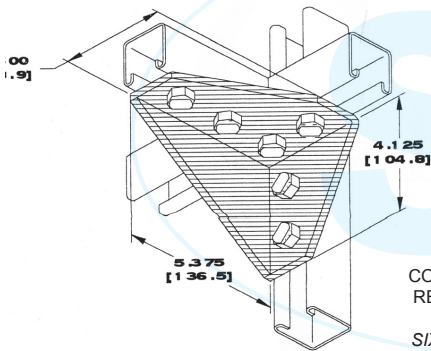

LU-1956
 CONECTOR DE ESQUINA
 REFORZADO DERECHO
 6 ORIFICIOS
 SIX HOLE (RIGHT HAND)
 GUSSETED CORNER
 CONNECTION

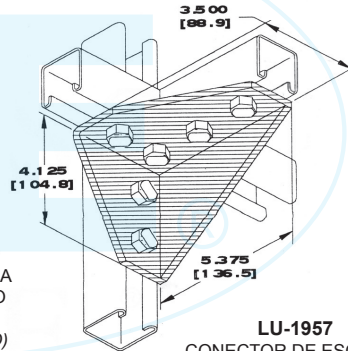

LU-1957
 CONECTOR DE ESQUINA
 REFORZADO IZQUIERDO
 6 ORIFICIOS
 SIX HOLE (LEFT HAND)
 GUSSETED CORNER
 CONNECTION

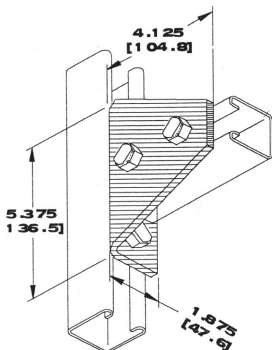

LU-1727
 CONECTOR ANGULAR 90°
 TIPO TRAPEZIO 4 ORIFICIOS
 FOUR HOLE GUSSETED CORNER

ESPECIFICACIONES (SPECIFICATIONS)

DIAMETRO DE ORIFICIO (HOLE SIZE): 14.3 (0,562)

ESPACIAMIENTO DEL CENTRO DE ORIFICIO AL

EXTREMO (HOLE SPACING): 20.6(0,812)

ESPACIAMIENTO ENTRE CENTRO DE

ORIFICIOS (HOLE SPACING): 47.6(1,875)

MATERIAL: ACERO AL CARBONO (STRIP STEEL)

ANCHO: 41.3(1,625)

ACABADO: GALVANIZADO ELECTROLITICO.

GALVANIZADO POR INMERSION EN CALIENTE

FINISHES: ELECTROLYTIC GALVANIZED, HOT-DIP

GALVANIZED

DIMENSIONES EN PULG. (MM)

DIMENSIONS ARE IN mm (Inch)

PUEDEN SER SUJETOS A MODIFICACION SIN PREVIO AVISO

MAY BE SUBJECT TO MODIFICATION WITHOUT NOTICE

CONEXIONES EN FORMA DE ALA

PARA UNICANAL

WING FITTINGS

FOR STRUT

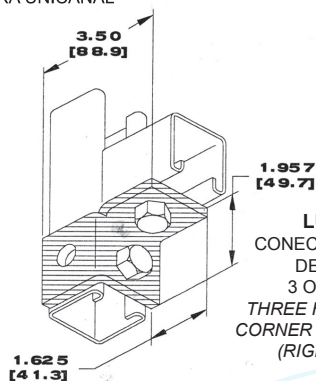

LU-2341R
 CONECTOR DE ALA
 DERECHA
 3 ORIFICIOS
 THREE HOLE SINGLE
 CORNER CONNECTION
 (RIGHT HAND)

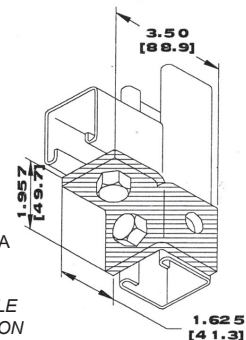

LU-2341L
 CONECTOR DE ALA
 IZQUIERDA
 3 ORIFICIOS
 THREE HOLE SINGLE
 CORNER CONNECTION
 (LEFT HAND)

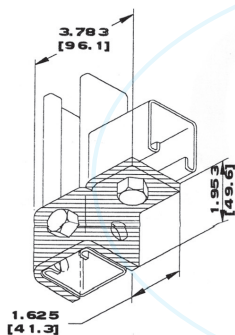

LU-2472R
 CONECTOR DE ALA
 DERECHA
 4 ORIFICIOS
 THREE HOLE SINGLE
 CORNER CONNECTION
 (RIGHT HAND)

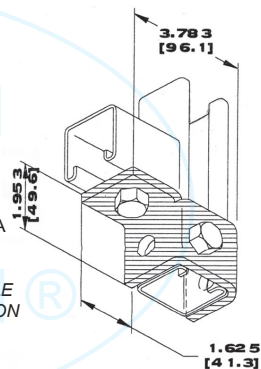

LU-2472L
 CONECTOR DE ALA
 IZQUIERDA
 4 ORIFICIOS
 THREE HOLE SINGLE
 CORNER CONNECTION
 (LEFT HAND)

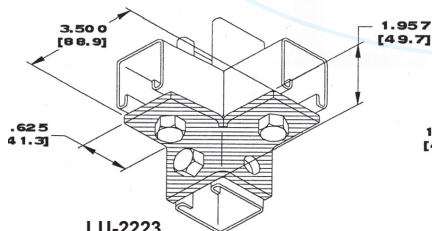

LU-2223
 CONECTOR DE ESQUINA
 DOBLE 4 ORIFICIOS
 FOUR HOLE DOUBLE
 CORNER CONNECTION

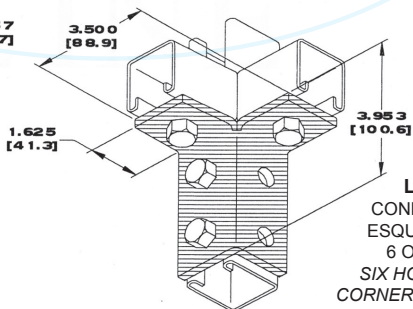

LU-2224
 CONECTOR DE
 ESQUINA DOBLE
 6 ORIFICIOS
 SIX HOLE DOUBLE
 CORNER CONNECTION

ESPECIFICACIONES (SPECIFICATIONS)

DIAMETRO DE ORIFICIO (HOLE SIZE): 14.3 (0,562)

ESPACIAMIENTO DEL CENTRO DE ORIFICIO EXTREMO (HOLE SPACING): 20.6(0,812)

ESPACIAMIENTO ENTRE CENTRO DE ORIFICIOS (HOLE SPACING): 47.6(1,875)

MATERIAL: ACERO AL CARBONO (STRIP STEEL) ANCHO: 41.3(1,625)

ACABADO: GALVANIZADO ELECTROLITICO. GALVANIZADO POR INMERSION EN CALIENTE

FINISHES: ELECTROLYTIC GALVANIZED, HOT-DIP GALVANIZED

DIMENSIONES EN PULG. (MM) / DIMENSIONS ARE IN mm (Inch)

PUEDEN SER SUJETOS A MODIFICACION SIN PREVIO AVISO / MAY BE SUBJECT TO MODIFICATION WITHOUT NOTICE

CONEXIONES EN FORMA DE ALA

PARA UNICANAL

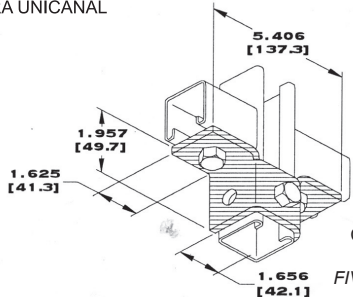

LU-2345
CONECTOR DE 2 ALAS
5 ORIFICIOS
FIVE HOLE DOUBLE WING
CONNECTION

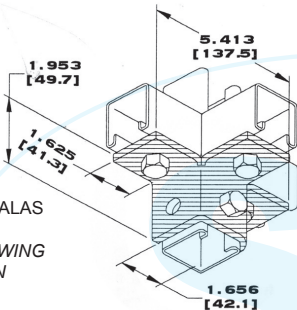

LU-2227
CONECTOR DE 3 ALAS
6 ORIFICIOS
SIX HOLE TRIPLE WING
CONNECTION

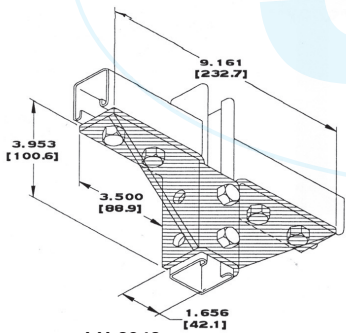

LU-2348
CONECTOR DE 2 ALAS
10 ORIFICIOS REFORZADO
TEN HOLE DOUBLE WING
GUSSETED CONNECTION

WING FITTINGS

FOR STRUT

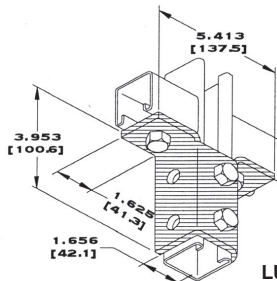

LU-2346
CONECTOR DE 2 ALAS
8 ORIFICIOS
EIGHT HOLE DOUBLE WING
CONNECTION

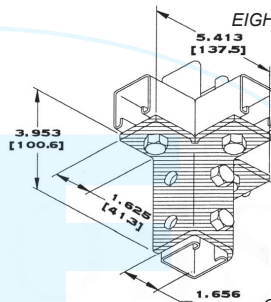

LU-2228
CONECTOR DE 3 ALAS
9 ORIFICIOS
NINE HOLE TRIPLE WING
CONNECTION

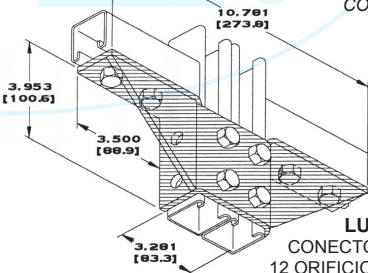

LU-2348A
CONECTOR DE 2 ALAS
12 ORIFICIOS REFORZADO
TWELVE HOLE DOUBLE WING
GUSSETED CONNECTION

ESPECIFICACIONES (SPECIFICATIONS)

DIAMETRO DE ORIFICIO (HOLE SIZE): 14.3 (0,562)

ESPACIAMIENTO DEL CENTRO DE ORIFICIO EXTREMO (HOLE SPACING): 20.6(0,812)

ESPACIAMIENTO ENTRE CENTRO DE ORIFICIOS (HOLE SPACING): 47.6(1,875)

MATERIAL: ACERO AL CARBONO (STRIP STEEL) ANCHO: 41.3(1,625)

ACABADO: GALVANIZADO ELECTROLITICO. GALVANIZADO POR INMERSION EN CALIENTE

FINISHES: ELECTROLYTIC GALVANIZED, HOT-DIP GALVANIZED

DIMENSIONES EN PULG. (MM) / DIMENSIONS ARE IN mm (Inch)

PUEDEN SER SUJETOS A MODIFICACION SIN PREVIO AVISO / MAY BE SUBJECT TO MODIFICATION WITHOUT NOTICE

CONEXIONES ANGULARES

PARA UNICANAL

ANGULAR FITTINGS

FOR STRUT

CONECTOR ANGULAR ABIERTO 2 ORIFICIOS TWO HOLE OPEN ANGLE			
No. CAT	A (ANGULO)	B MM (PULG)	C MM (PULG)
LU-2096	67.5°	88.9 (3.500")	44.5 (1.752")
LU-2097	60°	85.7 (3.374")	47.6 (1.874")
LU-2098	52.5°	82.6 (3.252")	52.4 (2.063")
LU-1546	45°	76.2 (3.000")	58.7 (2.311")
LU-2099	37.5°	88.9 (3.500")	46.0 (1.811")
LU-2101	30°	82.6 (3.252")	52.4 (2.063")
LU-2102	22.5°	84.1 (3.311")	52.4 (2.063")

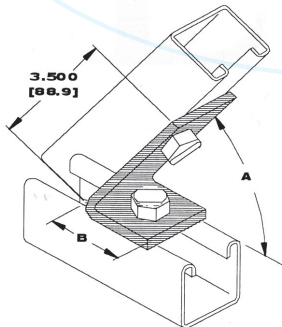
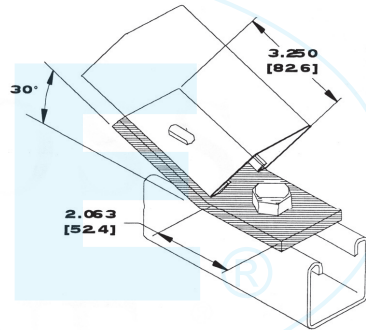
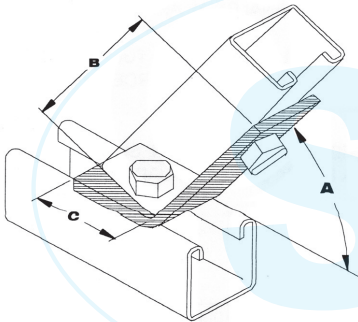

CONECTOR ANGULAR CERRADO 2 ORIFICIOS TWO HOLE CLOSED ANGLE		
No. CAT	A (ANGULO)	B MM (PULG)
LU-2106	75°	66.7 (2.626")
LU-2108	60°	70.6 (2.780")
LU-2109	52.5°	73.8 (2.906")
LU-2110	37.5°	81.8 (3.220")

ESPECIFICACIONES (SPECIFICATIONS)

DIAMETRO DE ORIFICIO (HOLE SIZE): **14.3 (0.562)**

ESPACIAMIENTO DEL CENTRO DE ORIFICIO EXTREMO (HOLE SPACING): **20.6(0,812)**

ESPACIAMIENTO ENTRE CENTRO DE ORIFICIOS (HOLE SPACING): **47.6(1,875)**

MATERIAL: ACERO AL CARBONO (STRIP STEEL) ANCHO: **41.3(1,625)**

ACABADO: GALVANIZADO ELECTROLITICO. GALVANIZADO POR INMERSION EN CALIENTE

FINISHES: ELECTROLYTIC GALVANIZED, HOT-DIP GALVANIZED

DIMENSIONES EN PULG. (MM) / DIMENSIONS ARE IN mm (Inch)

PUEDEN SER SUJETOS A MODIFICACION SIN PREVIO AVISO / MAY BE SUBJECT TO MODIFICATION WITHOUT NOTICE

SECCION 5.3 ACCESORIOS DE MONTAJE PARA UNICANAL

SECTION 5.3.- STRUT ACCESSORIES

TUERCAS

NUTS

CARACTERÍSTICAS FEATURES

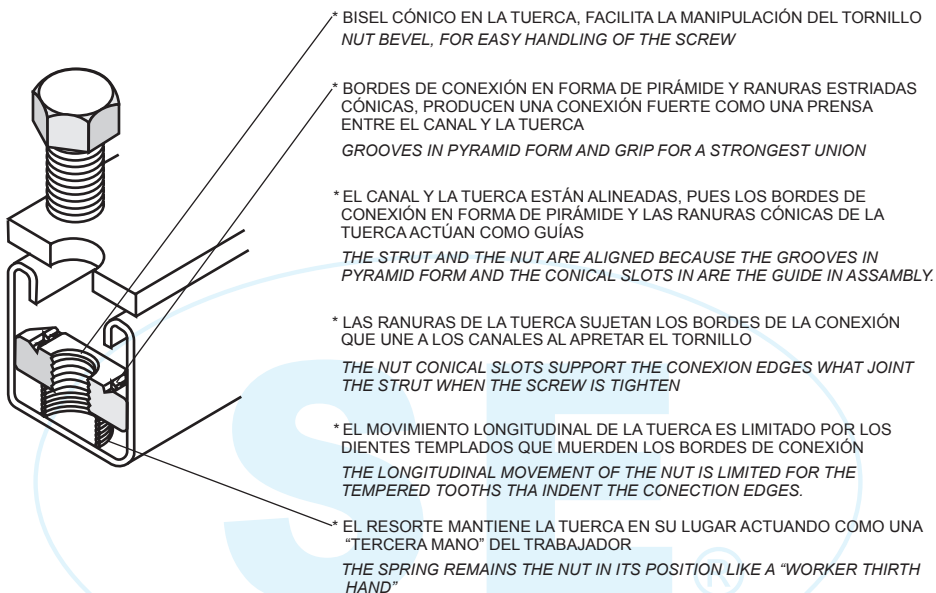

TUERCAS PARA UNICANAL SERIES LU-1000, LU-2000, LU-5500 Y LU-6000
NUTS FOR SERIES LU-1000, LU-2000, LU-5500 Y LU-6000 STRUT

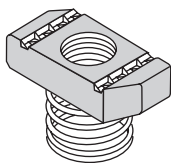

NUMERO DE CATALOGO CATALOG NUMBER		ROSCA THREAD	ESPESOR THICKNESS mm (Pulg)
CON RESORTE WITH SPRING	SIN RESORTE WITHOUT SPRING		
LU-1006	LU-3006	1/4-20UNC	6.4 (0.250)
LU-1007	LU-3007	5/16-18UNC	6.4 (0.250)
LU-1008	LU-3008	3/8-16UNC	9.5 (0.375)
LU-1010	LU-3010	1/2-13UNC	9.5 (0.375)

PARA UNICANALES SERIES 3300, 4000 Y COMBINACIONES
USAR TUERCAS SIN RESORTE

FOR 3300 Y 4000 STRUT SERIES AND COMBINATIONS
USE ONLY NUTS WITHOUT SPRING

MATERIAL: ACERO AL CARBONO
ACABADO: GALVANIZADO ELECTROLITICO
MATERIAL: CARBON STEEL
FINISHES: ELECTROGALVANIZED ZINC

PUEDER SER SUJETO A MODIFICACION SIN PREVIO AVISO / MAYBE SUBJECT TO MODIFICATION WITHOUT NOTICE

BASES PARA POSTES

POST BASES

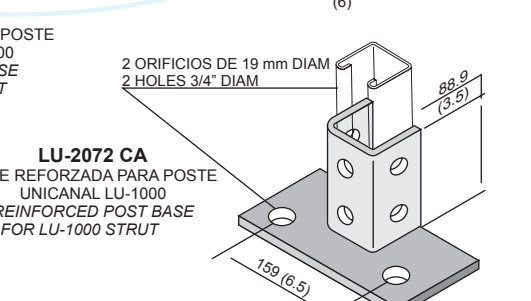
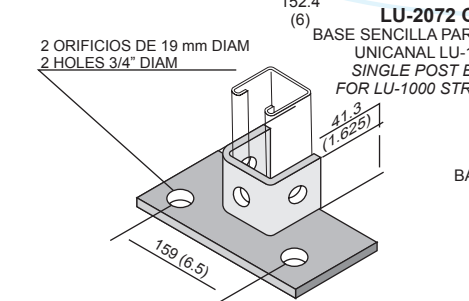
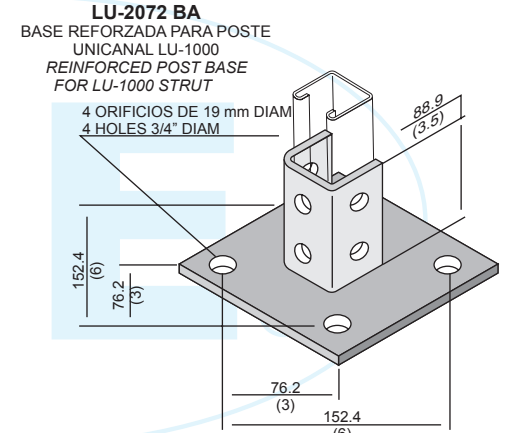
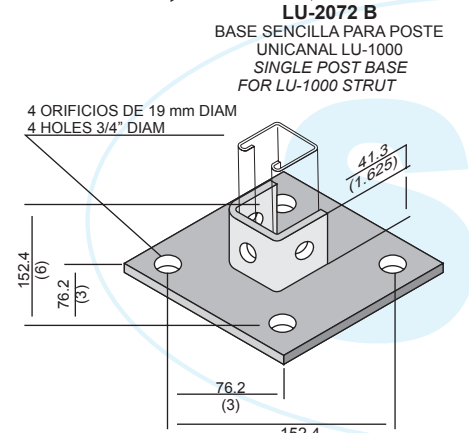
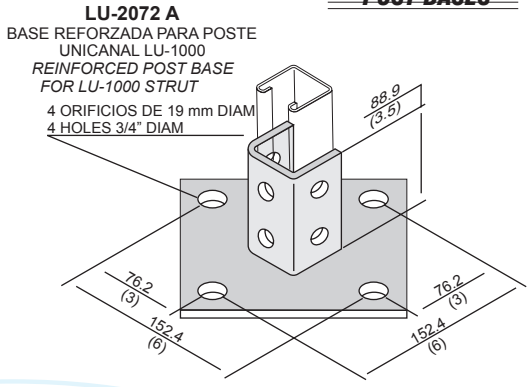
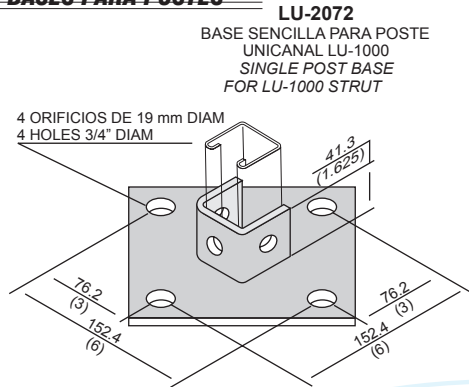

MATERIAL: ACERO AL CARBONO
 ACABADO: GALVANIZADO ELECTROLITICO, POR INMERSION EN CALIENTE Y TROPICALIZADO
 MATERIAL: CARBON STEEL
 FINISHES: ELECTROGALVANIZED ZINC, HOT DIP GALVANIZED AND CHROMIUM/ZINC COAT
 PARA BASES DE POSTE APLICABLES A OTROS CANALES CONSULTE A NUESTRO DEPARTAMENTO TECNICO
 FOR OTHER CHANNEL POST BASE PLEASE CONSULT OUR TECHNICAL DEPARTMENT

PUEDEN SER SUJETOS A MODIFICACION SIN PREVIO AVISO / MAYBE SUBJECT TO MODIFICATION WITHOUT NOTICE

BASE PARA POSTE

CANAL LU 1001
LU-2073

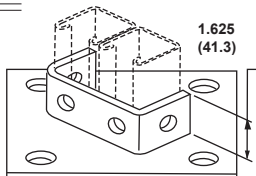

POST BASE

CANAL LU 1001
LU-2073 A

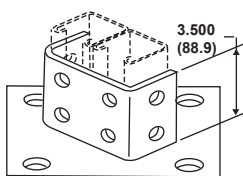

MENSULAS PARA UNICANAL

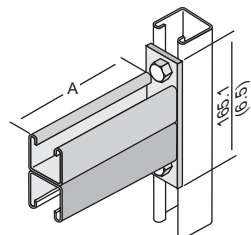
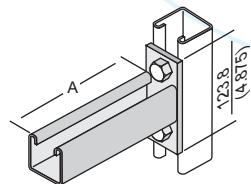
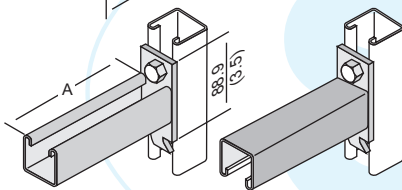
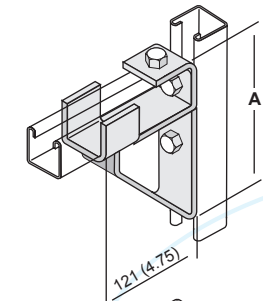

STRUT BRACKETS

**MENSULAS DE UNION (NO CARGA CANTILIVER)
UNION BRACKET (NOT FOR STRENGTH)**

NUMERO DE CATALOGO CATALOG NUMBER	CANAL CHANNEL	ALTURA A HIGH A
LU-1075	LU-1000/LU-3301	149.2 (5.875)
LU-1593	LU-1001	190.5 (7.5)
LU-1076	LU-3300	128.6 (5.06)
LU-1077	LU-5500	169.8 (6.68)
LU-1077A	LU-5501	231.7 (9.12)

**MENSULAS DE CANAL ENSAMBLE TIPO PESTAÑA
STRUT BRACKET LIFT TYPE ASSEMBLY**

NUMERO DE CATALOGO CATALOG NUMBER		ANCHO DE CHAROLA TRAY WIDTH	LONGITUD LENGHT A	CARGA UNIFORME UNIFORM LOAD
RANURA SUPERIOR LIPS UP	RANURA INFERIOR LIPS DOWN			
LU-2511	LU-2511A	101.6 (4)	152.4 (6)	544 kg
LU-2512	LU-2512A	152.4 (6)	203.2 (8)	453 kg
LU-2513	LU-2513A	228.6 (9)	279.4 (11)	317 kg
LU-2514	LU-2514A	304.8 (12)	355.6 (14)	249 kg
LU-2515	LU-2515A	457.2 (18)	508.0 (20)	181 kg
LU-2516	LU-2516A	609.6 (24)	660.4 (26)	130 kg
LU-2517	LU-2517A	762.0 (30)	812.8 (32)	113 kg
LU-2518	LU-2518A	914.4 (36)	965.2 (38)	96 kg

**MENSULAS DE CANAL SENCILLO ENSAMBLE TIPO PARED
SINGLE STRUT BRACKET WALL TYPE**

NUMERO DE CATALOGO CATALOG NUMBER	ANCHO DE CHAROLA TRAY WIDTH	LONGITUD LENGHT A	CARGA UNIFORME UNIFORM LOAD	
			LU-1000	LU-2000
LU-2539	101.6 (4)	152.4 (6)	544 kg	408 kg
LU-2540	152.4 (6)	203.2 (8)	453 kg	340 kg
LU-2541	228.6 (9)	279.4 (11)	317 kg	238 kg
LU-2542	304.8 (12)	355.6 (14)	249 kg	187 kg
LU-2543	457.2 (18)	508.0 (20)	181 kg	136 kg
LU-2544	609.6 (24)	660.4 (26)	130 kg	97 kg
LU-2545	762.0 (30)	812.8 (32)	113 kg	85 kg
LU-2546	914.4 (36)	965.2 (38)	96 kg	72 kg

**MENSULAS DE CANAL DOBLE ENSAMBLE TIPO PARED
DOUBLE STRUT BRACKET WALL TYPE**

NUMERO DE CATALOGO CATALOG NUMBER	ANCHO DE CHAROLA TRAY WIDTH	LONGITUD LENGHT A	CARGA UNIFORME UNIFORM LOAD	
			LU-1001	LU-2001
LU-2539A	101.6 (4)	152.4 (6)	1813 kg	1359 kg
LU-2540A	152.4 (6)	203.2 (8)	1511 kg	1133 kg
LU-2541A	228.6 (9)	279.4 (11)	1058 kg	793 kg
LU-2542A	304.8 (12)	355.6 (14)	831 kg	623 kg
LU-2543A	457.2 (18)	508.0 (20)	604 kg	453 kg
LU-2544A	609.6 (24)	660.4 (26)	434 kg	325 kg
LU-2545A	762.0 (30)	812.8 (32)	377 kg	282 kg
LU-2546A	914.4 (36)	965.2 (38)	321 kg	240 kg

MATERIAL: ACERO AL CARBONO

ACABADO: GALVANIZADO ELECTROLITICO, POR INMERSION EN CALIENTE Y TROPICALIZADO

MATERIAL: CARBON STEEL

FINISHES: ELECTROGALVANIZED ZINC, HOT DIP GALVANIZED AND CHROMIUM/ZINC COAT

DIMENSIONES DIMENSIONS mm (Pulg) / DIMENSIONS ARE IN mm (Inch)

PUEDEN SER SUJETOS A MODIFICACION SIN PREVIO AVISO / MAY BE SUBJECT TO MODIFICATION WITHOUT NOTICE

MORDAZAS DE VIGA PARA UNICANAL

STRUT BEAM CLAMPS

LU-1271S

MORDAZA DE VIGA EXTERIOR
CARGA RECOMENDADA 227kg
PARA CADA MORDAZA.
APLICABLES PARA VIGAS CON
ESPESORES DE 22.2 Y MENORES
CADA MORDAZA INCLUYE TORNILLO
CABEZA HEXAGONAL
SE DEBE UTILIZAR EN PARES
APLICABLE A CANALES SERIES
1000, 2000, 3301 Y 4001

EXTERNAL BEAM CLAMP
DESIGN LOAD 500 lb EACH ONE
AVAILABLE FOR 7/8" OR LESS
BEAM THICKNESS
ONE
SCREW INCLUDED FOR CLAMP
IT SHOULD BE USED IN PAIRS
FOR USE IN STRUT SERIES
1000, 2000, 3301 Y 4001

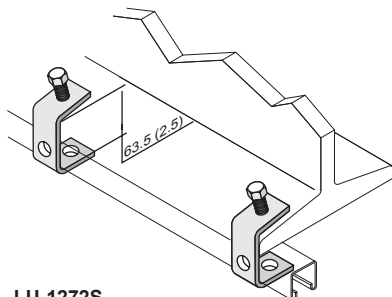

LU-1272S

MORDAZA DE VIGA INTERIOR
CARGA RECOMENDADA 204 kg
PARA CADA MORDAZA.
APLICABLES PARA VIGAS CON
ESPESORES DE 19 Y MENORES
CADA MORDAZA INCLUYE TORNILLO
CABEZA HEXAGONAL
SE DEBE UTILIZAR EN PARES
APLICABLE A TODAS LAS SERIES DE CANALES

INTERNAL BEAM CLAMP
DESIGN LOAD 450 lb EACH ONE
AVAILABLE FOR 3/4" OR LESS
BEAM THICKNESS
ONE
SCREW INCLUDED FOR CLAMP
IT SHOULD BE USED IN PAIRS
FOR USE IN ALL STRUT SERIES

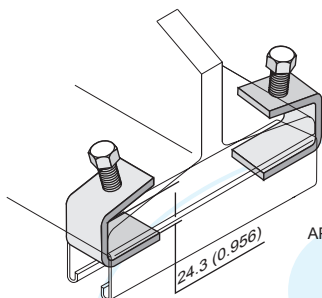

LU-1796S

MORDAZA DE VIGA TIPO INSERCIÓN
CARGA RECOMENDADA 217kg
PARA CADA MORDAZA.
APLICABLES PARA VIGAS CON
ESPESORES DE 22.2 Y MENORES
CADA MORDAZA INCLUYE TORNILLO
CABEZA HEXAGONAL
SE DEBE UTILIZAR EN PARES
APLICABLE A CANALES SERIES
1000, 2000, 3301 Y 4001

INSERTION BEAM CLAMP
DESIGN LOAD 480 lb EACH ONE
AVAILABLE FOR 7/8" OR LESS
BEAM THICKNESS
ONE
SCREW INCLUDED FOR CLAMP
IT SHOULD BE USED IN PAIRS
FOR USE IN STRUT SERIES
1000, 2000, 3301 Y 4001

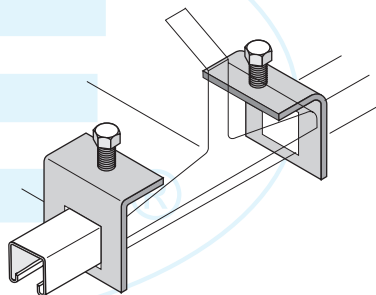

LU-2785

MORDAZA DE VIGA TIPO ABRAZADERA
CARGA RECOMENDADA 455kg
PARA CADA MORDAZA.
APLICABLES PARA VIGAS CON
ESPESORES DE 22.2 Y MENORES
SE DEBE UTILIZAR EN PARES
APLICABLE A CANALES SERIES
1000, 2000, 3301 Y 4001

BEAM CLAMP
DESIGN LOAD 1000 lb EACH ONE
AVAILABLE FOR 7/8" OR LESS
BEAM THICKNESS
IT SHOULD BE USED IN PAIRS
FOR USE IN STRUT SERIES
1000, 2000, 3301 Y 4001

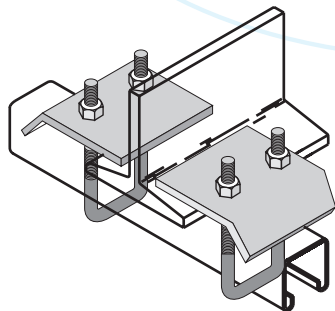

MATERIAL: ACERO AL CARBONO
ACABADO: GALVANIZADO ELECTROLITICO, POR INMERSION EN CALIENTE Y TROPICALIZADO
MATERIAL: CARBON STEEL
FINISHES: ELECTROGALVANIZED ZINC, HOT DIP GALVANIZED AND CHROMIUM/ZINC COAT
DIMENSIONES / DIMENSIONS mm (Pulg)

PARA MORDAZAS A CANALES DIFERENTES A LOS MOSTRADOS, CONSULTE NUESTRO DEPARTAMENTO TECNICO
FOR BEAM CLAMP USED IN CHANNEL NOT SHOWN, PLEASE CONTACT OUR TECHNICAL DEPARTMENT

PUEDE SER SUJETO A MODIFICACION SIN PREVIO AVISO / MAYBE SUBJECT TO MODIFICATION WITHOUT NOTICE

ABRAZADERA DE VIGA PARA UNICANAL

STRUT BEAM CLAMPS

LU-2868

ABRAZADERA PARA VIGA
APLICABLES PARA VIGAS CON
ESPESORES DE 22.2 Y MENORES
SE DEBE UTILIZAR EN PARES
APLICABLE A CANALES SERIES
1000, 2000, 3301 Y 4001

BEAM CLAMP
AVAILABLE FOR 7/8" OR LESS
BEAM THICKNESS
IT SHOULD BE USED IN PAIRS
FOR USE IN STRUT SERIES
1000, 2000, 3301 Y 4001

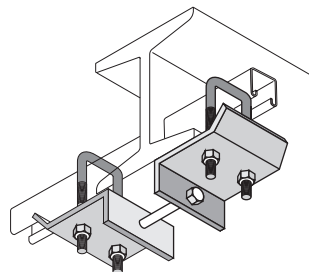
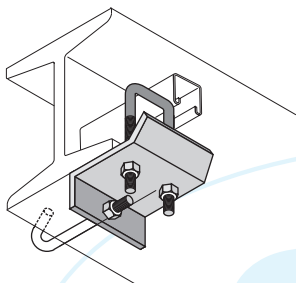

LU-2867

ABRAZADERA PARA VIGA
APLICABLES PARA VIGAS CON
ESPESORES DE 22.2 Y MENORES
APLICABLE A CANALES SERIES
1000, 2000, 3301 Y 4001

BEAM CLAMP
AVAILABLE FOR 7/8" OR LESS
BEAM THICKNESS
FOR USE IN STRUT SERIES
1000, 2000, 3301 Y 4001

PARA MORDAZAS A CANALES DIFERENTES A LOS MOSTRADOS, CONSULTE NUESTRO DEPARTAMENTO TECNICO
FOR BEAM CLAMP USED IN STRUT NOT SHOWN, PLEASE CONTACT OUR TECHNICAL DEPARTMENT

MORDAZA PARA USARSE CON VARILLA
DE 3/8" O
BEAM CLAMP FOR 3/8" OR
ROD ACCORDING DESIGN LOAD

TORNILLO OPRESOR CABEZA
HEXAGONAL 3/8" O
3/8" OR

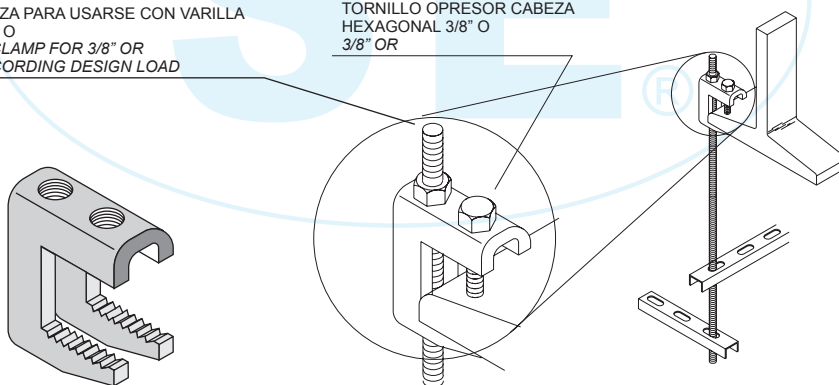

NUMERO DE CATALOGO CATALOG NUMBER	TORNILLO HEX SCREW	VARILLA THREADED ROD	CARGA RECOMENDADA DESIGN LOAD
LU-2676 3/8	3/8-16UNC	3/8-16UNC	250 kg
LU-2676			400 kg

MATERIAL: ACERO AL CARBONO

ACABADO: GALVANIZADO ELECTROLITICO, INMERSION EN CALIENTE Y TROPICALIZADO

MATERIAL: CARBON STEEL

FINISHES: ELECTROGALVANIZED ZINC, HOT DIP GALVANIZED AND CHROMIUM/ZINC COAT

DIMENSIONES EN PULG. (MM) / DIMENSIONS ARE IN mm (Inch)

PUEDEN SER SUJETOS A MODIFICACION SIN PREVIO AVISO / MAY BE SUBJECT TO MODIFICATION WITHOUT NOTICE

PRODUCTOS SOPORTES ELECTRICOS

CARGAS DE APOYO

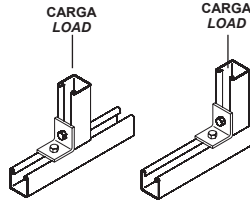

BEARING LOAD

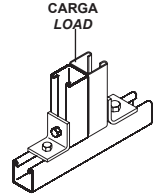

CANAL SERIE CHANNEL SERIES	AREA DE APOYO BEARING AREA		MAXIMA CARGA PERMISIBLE MAXIMUM ALLOWABLE LOAD				CANAL SERIE STRUT SERIES	AREA DE APOYO BEARING AREA		MAXIMA CARGA PERMISIBLE MAXIMUM ALLOWABLE LOAD	
	mm	Pulg	lb	kN	lb	kN		mm	Pulg	lb	kN
LU-1000	41.3 X 41.3	1 5/8 X 1 5/8	5,000	22.2	3,500	15.5	LU-1001	41.3 X 82.6	1 5/8 X 3 1/4	8,000	35.6
LU-2000	41.3 X 41.3	1 5/8 X 1 5/8	2,000	8.9	1,500	6.6	LU-2001	41.3 X 82.6	1 5/8 X 3 1/4	3,000	13.3
LU-3300	41.3 X 20.6	1 5/8 X 13/16	5,000	22.5	3,500	15.5	LU-3301	41.3 X 41.3	1 5/8 X 1 5/8	8,000	35.6
LU-4000	41.3 X 20.6	1 5/8 X 13/16	3,400	15	2,600	11.5	LU-4001	41.3 X 41.3	1 5/8 X 1 5/8	4,800	21.4
LU-5500	41.3 X 61.9	1 5/8 X 2 7/16	5,000	22.2	3,500	15.5	LU-5501	41.3 X 123.8	1 5/8 X 4 7/8	8,000	35.6
LU-6000	41.3 X 61.9	1 5/8 X 2 7/16	3,500	15.5	2,700	12.0	LU-6001	41.3 X 123.8	1 5/8 X 4 7/8	4,900	21.7

CARGAS PERMISIBLES PARA CONEXIONES TÍPICAS DE LOS UNICANALES

DESIGN LOAD DATA FOR TYPICAL STRUT CONNECTIONS

PLACAS DE CONEXION A 90° (CUANDO DE USAN EN LA POSICION MOSTRADA)
90° FITTINGS (WHEN USED IN POSITION SHOWN)

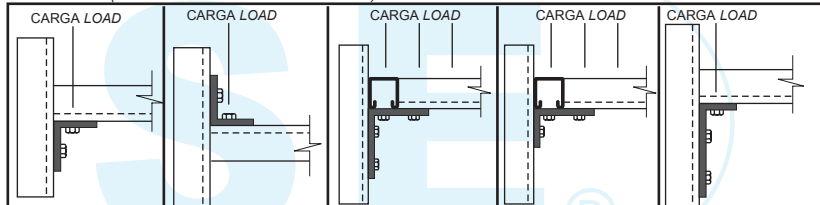

UNICANAL SERIE STRUT SERIES	LU-1026		LU-1026		LU-1325 Y LU-2235		LU-1458 Y LU-1579		LU-1346	
	lb	kg	lb	kg	lb	kg	lb	kg	lb	kg
LU-1000, LU-3300, LU-5500	1500	680	1000	450	2000	900	1500	680	2000	900
LU-2000, LU-4000, LU-6000	1000	450	650	290	2000	900	1000	450	1500	450

PLACAS DE CONEXION A 90° (CUANDO DE USAN EN LA POSICION MOSTRADA)
90° FITTINGS (WHEN USED IN POSITION SHOWN)

PLACA PLANA
FLAT PLATE

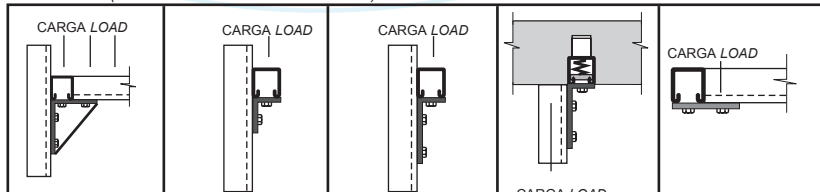

UNICANAL SERIE STRUT SERIES	LU-1957		LU-1068		LU-1326		LU-1346		LU-1346	
	lb	kg	lb	kg	lb	kg	lb	kg	lb	kg
LU-1000, LU-3300, LU-5500	3000	1360	500	220	500	220	1200	540	1000	450
LU-2000, LU-4000, LU-6000	2000	900	500	220	500	220	1200	540	800	360

VIGA SOPORTADA EN AMBOS EXTREMOS
CARGAS BASADAS EN UNA CONEXION CON TUERCA LU-1010 Y TORNILLOS DE
FACTOR DE SEGURIDAD = 2.5 BASADO EN LA RESISTENCIA ULTIMA DE LA CONEXION
BOTH ENDS OF BEAMS SUPPORTED
LOAD DATA IS BASED ON LU-1010 NUT AND

SAFETY FACTOR = 2.5 BASED ON ULTIMATE STRENGTH OF CONECTION

PUEDER SER SUJETO A MODIFICACION SIN PREVIO AVISO / MAYBE SUBJECT TO MODIFICATION WITHOUT NOTICE

SECCION 5.4 DATOS DE INGENIERIA

SECTION 5.4 TECHNICAL DATA

PESOS

WEIGHT

PESO APROXIMADO POR CANAL DE 3.048 m DE LONGITUD APROXIMATE WEIGHT FOR 10' CHANNEL LENGHT

No DE CATALOGO CAT. NUMBER	PESO WEIGHT		No DE CATALOGO CAT. NUMBER	PESO WEIGHT		No DE CATALOGO CAT. NUMBER	PESO WEIGHT	
	kg	lb		kg	lb		kg	lb
LU-1000	8.8	19.4	LU-3300	6	13.2	LU-5500	11.2	24.7
LU-1001	17.6	38.8	LU-3301	12	26.4	LU-5501	22.4	49.4
LU-2000	6.4	14.1	LU-4000	4.4	9.7	LU-6000	9.1	20.1
LU-2001	12.8	28.2	LU-4001	8.8	19.4	LU-6001	18.2	40.1

CANAL CON INSERTOS SUMAR 1.4 kg
FOR CONCRET INSERT PLUS 3 lb
PARA PRLU- RESTAR 0.2 kg
FOR PRLU- REDUCE 0.44 lb
PARA PSLU- RESTAR 0.4 kg
FOR PSLU- REDUCE 0.88 lb
LU-3184 P = 0.42 kg PIEZA 0.92lb UNIT

PESO APROXIMADO POR 100 PIEZAS DE ACERO GALVANIZADO POR INMERSION
APPROXIMATE WEIGHT FOR 100 PIECES STEEL HOT DIP GALVANIZED

No DE CATALOGO CAT. NUMBER	PESO WEIGHT		No DE CATALOGO CAT. NUMBER	PESO WEIGHT		No DE CATALOGO CAT. NUMBER	PESO WEIGHT		No DE CATALOGO CAT. NUMBER	PESO WEIGHT	
	kg	lb		kg	lb		kg	lb		kg	lb
LU-1006	3	7	LU-1118	18	40	LU-2072B	139	307	LU-2514A	73	161
LU-1007	3	6	LU-1119	21	47	LU-2072BA	169	373	LU-2515	102	225
LU-1008	5	10	LU-1120	23	51	LU-2072C	139	307	LU-2515A	102	225
LU-1010	5	12	LU-1121	30	67	LU-2072CA	169	373	LU-2516	118	261
LU-1026	17	38	LU-1123	35	80	LU-2096	26	58	LU-2516A	118	261
LU-1028	48	105	LU-1124	46	108	LU-2097	26	58	LU-2517	163	361
LU-1031	36	80	LU-1271S	43	95	LU-2098	26	58	LU-2517A	163	361
LU-1033	36	80	LU-1272S	18	39	LU-2099	26	58	LU-2518	209	461
LU-1034	36	80	LU-1320	29	63	LU-2101	26	58	LU-2518A	209	461
LU-1035	36	80	LU-1325	35	78	LU-2102	26	58	LU-2539	50	110
LU-1036	26	58	LU-1326	26	58	LU-2106	26	58	LU-2539A	100	220
LU-1037	26	58	LU-1346	26	58	LU-2108	26	58	LU-2540	55	121
LU-1038	26	58	LU-1356	32	70	LU-2109	26	58	LU-2541	75	165
LU-1043A	48	105	LU-1357	32	70	LU-2110	26	58	LU-2541A	150	330
LU-1044	32	70	LU-1358	48	105	LU-2223	35	77	LU-2542	90	198
LU-1045	25	55	LU-1359	48	105	LU-2224	52	114	LU-2543	130	286
LU-1046A	35	77	LU-1376	58	128	LU-2227	52	114	LU-2544	150	330
LU-1047	40	88	LU-1376A	89	197	LU-2228	80	176	LU-2545	200	440
LU-1062	8	18	LU-1377	120	265	LU-2235	61	135	LU-2545A	486	1070
LU-1063	8	18	LU-1453	32	70	LU-2324	34	75	LU-2546	240	528
LU-1064	8	18	LU-1458	26	58	LU-2325	25	55	LU-2546A	572	1258
LU-1065	17	38	LU-1546	26	58	LU-2341R	27	60	LU-2676	19	42
LU-1066	25	56	LU-1579	47	103	LU-2341L	27	60	LU-2785	39	87
LU-1067	35	78	LU-1593	112	246	LU-2345	42	92	LU-2867	58	129
LU-1068	17	38	LU-1727	70	154	LU-2346	68	150	LU-2868	93	206
LU-1075	104	229	LU-1728	70	154	LU-2348	124	294	LU-2944A	110	242
LU-1076	104	229	LU-1736	32	70	LU-2348A	136	299	LU-2945A	227	500
LU-1077	104	229	LU-1737	58	128	LU-2472R	34	75	LU-2946A	314	691
LU-1077A	112	246	LU-1796S	49	180	LU-2472L	34	75	LU-2947A	400	880
LU-1109	5	11	LU-1941	43	94	LU-2511	40	88	LU-3006	3	6
LU-1111	5	11	LU-1950	109	240	LU-2511A	40	88	LU-3007	3	6
LU-1112	6	15	LU-1953	80	176	LU-2512	60	132	LU-3008	4	3
LU-1113	8	17	LU-1956	104	230	LU-2512A	60	132	LU-3010	5	11
LU-1114	9	19	LU-1957	104	230	LU-2513	45	100	LU-3345	18	40
LU-1115	13	29	LU-2072	139	307	LU-2513A	45	100	LU-3347	32	70
LU-1117	15	34	LU-2072A	169	373	LU-2514	73	161			

SECCION 6 ABRAZADERAS PARA TUBERIA

SECTION 6 PIPE CLAMPS

6.1 ABRAZADERA CONDUIT PARA UNICANAL

6.1 CHANNEL CONDUIT CLAMPS

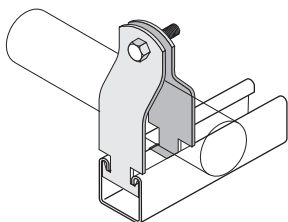

NUMERO DE CATALOGO CATALOG NUMBER	TAMANO NOMINAL CONDUIT SIZE	NUMERO DE CATALOGO CATALOG NUMBER	TAMANO NOMINAL CONDUIT SIZE
LU-1109	9.5 (3/8)	LU-1117	50.8 (2)
LU-1111	12.7 (1/2)	LU-1118	63.5 (2 1/2)
LU-1112	19.1 (3/4)	LU-1119	76.2 (3)
LU-1113	25.4 (1)	LU-1121	101.6 (4)
LU-1114	31.8 (1 1/4)	LU-1123	127.0 (5)
LU-1115	38.1 (1 1/2)	LU-1124	152.4 (6)

MATERIAL: ACERO AL CARBONO, ACERO INOXIDABLE, ALUMINIO
ACABADO: GALVANIZADO ELECTROLITICO, INMERSION EN CALIENTE Y TROPICALIZADO
MATERIAL: CARBON STEEL, STAINLESS STEEL, ALUMINUM
FINISHES: ELECTROGALVANIZED ZINC, HOT DIP GALVANIZED AND CHROMIUM/ZINC COAT
DIMENSIONES DIMENSIONS mm (Pulg)
TORNILLO Y TUERCA HEXAGONALES DE 1/4-20UNC X 19 LONG INCLUIDOS
1/4-20UNC X 3/4 LONG HEX HEAD SCREW AND NUT INCLUDED

PUEDER SER SUJETO A MODIFICACION SIN PREVIO AVISO / MAYBE SUBJECT TO MODIFICATION WITHOUT NOTICE

SECCION 6.2 - ABRAZADERAS PARA TUBERIA

SECTION 6.2 - PIPE CLAMPS

ABRAZADERA PARA TUBO CONDUIT A CHAROLA TIPO ANGULO RECTO

CONDUIT TO CABLE TRAY RIGHT ANGLE CLAMP

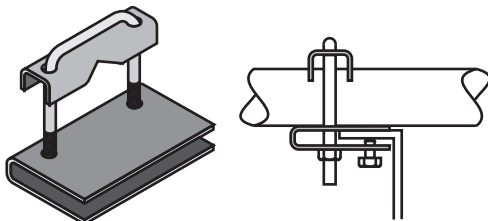

No DE CATALOGO CATALOG NUMBER	DIAMETRO NOMINAL CONDUIT SIZE
ACTM-01	DE 1/2 A 1
ACTM-02	DE 1 1/4 A 2 1/2
ACTM-03	DE 3 A 6

INCLUYE TORNILLERIA / HARDWARE INCLUDED

ABRAZADERA PARA TUBO CONDUIT A CHAROLA TIPO ANGULO VARIABLE

CONDUIT TO CABLE TRAY ANY ANGLE CLAMP

No DE CATALOGO CATALOG NUMBER	DIAMETRO NOMINAL CONDUIT SIZE
ACCTM-12	1/2
ACCTM-34	3/4
ACCTM-1	1
ACCTM-114	1 1/4
ACCTM-112	1 1/2
ACCTM-2	2
ACCTM-212	2 1/2
ACCTM-3	3
ACCTM-312	3 1/2
ACCTM-4	4

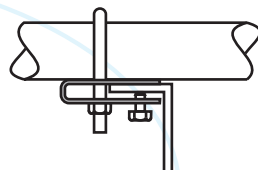

INCLUYE TORNILLERIA / HARDWARE INCLUDED

ABRAZADERA TIPO OMEGA

OMEGA-TYPE CLAMP

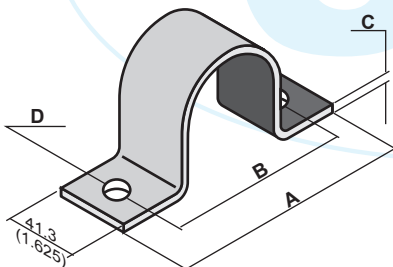

No DE CATALOGO CATALOG NUMBER	DIAMETRO NOMINAL CONDUIT SIZE	A	B	C	D
AOMEGA-12	1/2	73 (2.87)	51 (2.0)	3.18 (1/8)	7 (0.28)
AOMEGA-34	3/4	78 (3.06)	56 (2.18)	3.18 (1/8)	7 (0.28)
AOMEGA-1	1	86 (3.37)	64 (2.5)	3.18 (1/8)	7 (0.28)
AOMEGA-114	1 1/4	94 (3.68)	71 (2.81)	3.18 (1/8)	7 (0.28)
AOMEGA-112	1 1/2	100 (3.93)	78 (3.06)	3.18 (1/8)	7 (0.28)
AOMEGA-2	2	146 (5.75)	105 (4.12)	6.35 (1/4)	11 (0.43)
AOMEGA-212	2 1/2	157 (6.18)	116 (4.56)	6.35 (1/4)	11 (0.43)
AOMEGA-3	3	173 (6.81)	132 (5.18)	6.35 (1/4)	11 (0.43)
AOMEGA-4	4	198 (7.81)	157 (6.18)	6.35 (1/4)	11 (0.43)
AOMEGA-5	5	225 (8.87)	184 (7.25)	6.35 (1/4)	11 (0.43)
AOMEGA-6	6	252 (9.93)	211 (5.31)	6.35 (1/4)	11 (0.43)

MATERIALES Y ACABADOS:

MATERIALS & FINISHES :

- GI:** ACERO AL CARBONO GALVANIZADO POR INMERSION EN CALIENTE SEGUN ASTM A 123
- GE:** ACERO AL CARBONO GALVANIZADO ELECTROLITICO SEGUN ASTM B 633
- T:** ACERO AL CARBONO TROPICALIZADO
- PVC:** ACERO AL CARBONO CON RECUBRIMIENTO DE PVC SEGUN NEMA RN-1
- AI:** ACERO INOXIDABLE ACABADO NATURAL

- GI:** HOT DIP GALVANIZED UNDER ASTM-123 CARBON STEEL
- GE:** ELECTROGALVANIZED STEEL UNDER ASTM B 633
- T:** CHROMIUM/ZINC COATED CARBON STEEL
- PVC:** PVC COATED CARBON STEEL UNDER NEMA RN 1
- AI:** NATURAL FINISHED STAINLESS STEEL

TODAS LAS DIMENSIONES EN mm (Pulg) / ALL DIMENSIONS ARE IN mm (Inch)

PUEDEN SER SUJETOS A MODIFICACION SIN PREVIO AVISO / MAY BE SUBJECT TO MODIFICATION WITHOUT NOTICE

6.3 ABRAZADERA TIPO "U" SERVICIO LIGERO

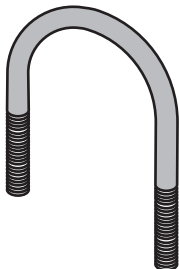

NO INCLUYE TUERCAS / NUTS NOT INCLUDED

6.3 LIGHT DUTY U-BOLT

No DE CATALOGO CATALOG NUMBER	DIAMETRO NOMINAL CONDUIT SIZE	DIAMETRO DE VARILLA ROD SIZE
AU120-12	1/2	6.3 (1/4)
AU120-34	3/4	6.3 (1/4)
AU120-1	1	6.3 (1/4)
AU120-114	1 1/4	6.3 (1/4)
AU120-112	1 1/2	6.3 (1/4)
AU120-2	2	6.3 (1/4)
AU120-212	2 1/2	9.5 (3/8)
AU120-3	3	9.5 (3/8)
AU120-312	3 1/2	9.5 (3/8)
AU120-4	4	9.5 (3/8)
AU120-5	5	9.5 (3/8)
AU120-6	6	12.7 (1/2)
AU120-8	8	12.7 (1/2)
AU120-10	10	15.8 (5/8)

ABRAZADERA TIPO "U" SERVICIO PESADO

No DE CATALOGO CATALOG NUMBER	DIAMETRO NOMINAL CONDUIT SIZE	DIAMETRO DE VARILLA ROD SIZE
AU137-114	1 1/4	9.5 (3/8)
AU137-1	1 1/2	9.5 (3/8)
AU137-2	2	9.5 (3/8)
AU137-212	2 1/2	12.7 (1/2)
AU137-3	3	12.7 (1/2)
AU137-312	3 1/2	12.7 (1/2)
AU137-4	4	12.7 (1/2)
AU137-5	5	12.7 (1/2)
AU137-6	6	15.8 (5/8)
AU137-8	8	15.8 (5/8)
AU137-10	10	19 (3/4)
AU137-12	12	22.2 (7/8)
AU137-14	14	22.2 (7/8)
AU137-16	16	22.2 (7/8)
AU137-18	18	25.4 (1)
AU137-20	20	25.4 (1)

HEAVY DUTY U-BOLT

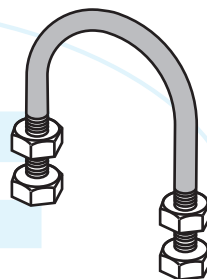

INCLUYE 4 TUERCAS / FOUR NUTS INCLUDED

ABRAZADERA TIPO "U" CON MORDAZA

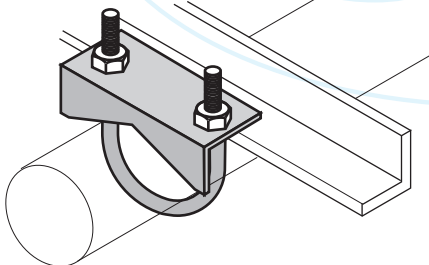

INCLUYE 2 TUERCAS TWO NUTS INCLUDED

BEAM U-BOLT CLAMP

No DE CATALOGO CATALOG NUMBER	DIAMETRO NOMINAL CONDUIT SIZE	DIAMETRO DE VARILLA ROD SIZE
AU M3012	1/2	6.3 (1/4)
AU M3034	3/4	6.3 (1/4)
AU M301	1	6.3 (1/4)
AU M30114	1 1/4	6.3 (1/4)
AU M30112	1 1/2	9.5 (3/8)
AU M302	2	9.5 (3/8)
AU M30212	2 1/2	12.7 (1/2)
AU M303	3	12.7 (1/2)
AU M30312	3 1/2	12.7 (1/2)
AU M304	4	12.7 (1/2)

MATERIALES Y ACABADOS:

- GE : ACERO AL CARBONO GALVANIZADO ELECTROLITICO SEGUN ASTM B 633
- T : ACERO AL CARBONO TROPICALIZADO
- PVC : ACERO AL CARBONO CON RECUBRIMIENTO DE PVC SEGUN NEMA RN-1
- AI : ACERO INOXIDABLE ACABADO NATURAL

MATERIALS & FINISHES :

- GE : ELECTROGALVANIZED STEEL UNDER ASTM B 633
- T : CHROMIUM/ZINC COATED CARBON STEEL
- PVC : PVC COATED CARBON STEEL UNDER NEMA RN 1
- AI : NATURAL FINISHED STAINLESS STEEL

TODAS LAS DIMENSIONES EN mm (Pulg) / ALL DIMENSIONS ARE IN mm (Inch)

PUEDEN SER SUJETOS A MODIFICACION SIN PREVIO AVISO / MAY BE SUBJECT TO MODIFICATION WITHOUT NOTICE

PRODUCTOS SOPORTES ELECTRICOS

6.4 ABRAZADERA COLGANTE TIPO PERA



NO INCLUYE TUERCAS *NUTS NOT INCLUDED*

6.4 ADJUSTABLE BAND PIPE HANGER

No DE CATALOGO CATALOG NUMBER	DIAMETRO NOMINAL CONDUIT SIZE	PARA VARILLA ROD SIZE FOR
AP269-12	1/2	9.5 (3/8)
AP269-34	3/4	9.5 (3/8)
AP269-1	1	9.5 (3/8)
AP269-114	1 1/4	9.5 (3/8)
AP269-112	1 1/2	9.5 (3/8)
AP269-2	2	9.5 (3/8)
AP269-212	2 1/2	12.7 (1/2)
AP269-3	3	12.7 (1/2)
AP269-312	3 1/2	12.7 (1/2)
AP269-4	4	12.7 (1/2)
AP269-5	5	12.7 (1/2)
AP269-6	6	19 (3/4)
AP269-8	8	22 (7/8)

ABRAZADERA TIPO COLUMPIO SERVICIO PESADO Y LIGERO

HEAVY & LIGHT DUTY CLEVIS HANGER

No DE CATALOGO CATALOG NUMBER		DIAMETRO NOMINAL CONDUIT SIZE	DIAMETRO DE VARILLA ROD SIZE
SERVICIO PESADO HEAVY DUTY	SERVICIO LIGERO LIGHT DUTY		
	ACO65-38	3/8	9.5 (3/8)
ACO260-12	ACO65-12	1/2	9.5 (3/8)
ACO260-34	ACO65-34	3/4	9.5 (3/8)
ACO260-1	ACO65-1	1	9.5 (3/8)
ACO260-114	ACO65-114	1 1/4	9.5 (3/8)
ACO260-112	ACO65-1	1 1/2	9.5 (3/8)
ACO260-2	ACO65-2	2	9.5 (3/8)
ACO260-212	ACO65-2	2 1/2	12.7 (1/2)
ACO260-3	ACO65-3	3	12.7 (1/2)
ACO260-312	ACO265-3	3 1/2	12.7 (1/2)
ACO260-4	ACO265-4	4	15.8 (5/8)
ACO260-5		5	15.8 (5/8)
ACO260-6		6	19 (3/4)
ACO260-8		8	22.2 (7/8)
ACO260-10		10	22.2 (7/8)
ACO260-12		12	22.2 (7/8)
ACO260-14		14	25.4 (1)
ACO260-16		16	25.4 (1)
ACO260-18		18	28.6 (1 1/8)
ACO260-20		20	31.8 (1 1/4)
ACO260-24		24	31.8 (1 1/4)
ACO260-30		30	31.8 (1 1/4)
ACO260-36		36	38.1 (1 1/2)



TORNILLO Y TUERCA DE UNION INCLUIDOS
UNION NUT AND SCREW INCLUDED

MATERIALES Y ACABADOS:

MATERIALS & FINISHES:

GI: ACERO AL CARBONO GALVANIZADO POR INMERSION EN CALIENTE SEGUN ASTM A 123
GE: ACERO AL CARBONO GALVANIZADO ELECTROLITICO SEGUN ASTM B 633
T: ACERO AL CARBONO TROPICALIZADO
PVC: ACERO AL CARBONO CON RECUBRIMIENTO DE PVC SEGUN NEMA RN-1
AI: ACERO INOXIDABLE ACABADO NATURAL

GI: HOT DIP GALVANIZED UNDER ASTM-123 CARBON STEEL
GE: ELECTROGALVANIZED STEEL UNDER ASTM B 633
T: CHROMIUM/ZINC COATED CARBON STEEL
PVC: PVC COATED CARBON STEEL UNDER NEMA RN 1
AI: NATURAL FINISHED STAINLESS STEEL

TODAS LAS DIMENSIONES EN mm (Pulg) / ALL DIMENSIONS ARE IN mm (Inch)

PUEDEN SER SUJETOS A MODIFICACION SIN PREVIO AVISO / MAY BE SUBJECT TO MODIFICATION WITHOUT NOTICE

ABRAZADERA COLGANTE DE DOBLE PERNO

DOUBLE BOLT PIPE HANGER CLAMP

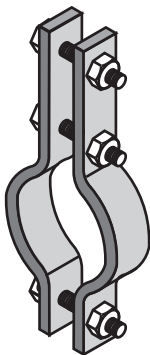

No DE CATALOGO CATALOG NUMBER	DIAMETRO NOMINAL CONDUIT SIZE	DIAMETRO DE TORNILLOS BOLT SIZE
ACD-34	3/4	9.5 (3/8)
ACD-1	1	9.5 (3/8)
ACD-114	1 1/4	9.5 (3/8)
ACD-112	1 1/2	15.8 (5/8)
ACD-2	2	15.8 (5/8)
ACD-212	2 1/2	15.8 (5/8)
ACD-3	3	15.8 (5/8)
ACD-312	3 1/2	15.8 (5/8)
ACD-4	4	19 (3/4)
ACD-5	5	19 (3/4)
ACD-6	6	22.2 (7/8)
ACD-8	8	22.2 (7/8)
ACD-10	10	25.4 (1)
ACD-12	12	25.4 (1)
ACD-14	14	31.8 (1 1/4)
ACD-16	16	31.8 (1 1/4)
ACD-18	18	31.8 (1 1/4)
ACD-20	20	34.9 (1 3/8)
ACD-24	24	34.9 (1 3/8)

ABRAZADERA DE UÑA PARA TUBERIA

PIPE HOOK CLAMP

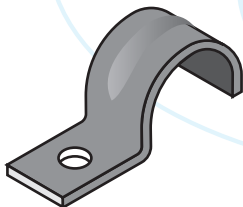

No DE CATALOGO CATALOG NUMBER		DIAMETRO NOMINAL CONDUIT SIZE	DIAM ORIFICIO HOLE DIAM
PARA CONDUIT RIGIDO FOR RIGID CONDUIT	PARA PARED DELGADA FOR E.M.T.		
APE-12	ALE-12	1/2	7.9 (5/16)
APE-34	ALE-34	3/4	7.9 (5/16)
APE-1	ALE-1	1	7.9 (5/16)
APE-114	ALE-114	1 1/4	11.1 (7/16)
APE-112	ALE-1	1 1/2	11.1 (7/16)
APE-2	ALE-2	2	11.1 (7/16)
APE-212		2 1/2	17.5 (11/16)
APE-3		3	17.5 (11/16)
APE-312		3 1/2	17.5 (11/16)
APE-4		4	17.5 (11/16)

MATERIALES Y ACABADOS:

MATERIALS & FINISHES :

- GI** : ACERO AL CARBONO GALVANIZADO POR INMERSION EN CALIENTE SEGUN ASTM A 123
- GE** : ACERO AL CARBONO GALVANIZADO ELECTROLITICO SEGUN ASTM B 633
- T** : ACERO AL CARBONO TROPICALIZADO
- PVC** : ACERO AL CARBONO CON RECURTIMIENTO DE PVC SEGUN NEMA RN-1
- AI** : ACERO INOXIDABLE ACABADO NATURAL

- GI** : HOT DIP GALVANIZED UNDER ASTM-123 CARBON STEEL
- GE** : ELECTROGALVANIZED STEEL UNDER ASTM B 633
- T** : CHROMIUM/ZINC COATED CARBON STEEL
- PVC** : PVC COATED CARBON STEEL UNDER NEMA RN 1
- AI** : NATURAL FINISHED STAINLESS STEEL

TODAS LAS DIMENSIONES EN mm (Pulg) / ALL DIMENSIONS ARE IN mm (Inch)

PUEDER SER SUJETO A MODIFICACION SIN PREVIO AVISO / MAY BE SUBJECT TO MODIFICATION WITHOUT NOTICE

INDICE POR No. DE CATALOGO

No. DE CAT.	PAG.	No. DE CAT.	PAG.	No. DE CAT.	PAG.	No. DE CAT.	PAG.
CHAROLAS TIPO ESCALERA		ACCESORIOS TIPO ESCALERA		ACCESORIOS TIPO ESCALERA		ACCESORIOS TIPO ESCALERA	
CH-0406	10	VH-24R1245	11	VH-20R2490	11	VE-18R3645	12
CH-0409	10	VH-30R1245	11	VH-24R2490	11	VE-20R3645	12
CH-0412	10	VH-36R1245	11	VH-30R2490	11	VE-24R3645	12
CH-0606	10	VH-04R2445	11	VH-36R2490	11	VE-30R3645	12
CH-0609	10	VH-06R2445	11	VH-04R3690	11	VE-36R3645	12
CH-0612	10	VH-09R2445	11	VH-06R3690	11	VE-04R0890	12
CH-0906	10	VH-12R2445	11	VH-09R3690	11	VE-06R0890	12
CH-0909	10	VH-16R2445	11	VH-12R3690	11	VE-09R0890	12
CH-0912	10	VH-18R2445	11	VH-16R3690	11	VE-12R0890	12
CH-1206	10	VH-20R2445	11	VH-18R3690	11	VE-16R0890	12
CH-1209	10	VH-24R2445	11	VH-20R3690	11	VE-18R0890	12
CH-1212	10	VH-30R2445	11	VH-24R3690	11	VE-20R0890	12
CH-1606	10	VH-36R2445	11	VH-30R3690	11	VE-24R0890	12
CH-1609	10	VH-04R3645	11	VH-36R3690	11	VE-30R0890	12
CH-1612	10	VH-06R3645	11	VE-04R0845	12	VE-36R0890	12
CH-1806	10	VH-09R3645	11	VE-06R0845	12	VE-04R1290	12
CH-1809	10	VH-12R3645	11	VE-09R0845	12	VE-06R1290	12
CH-1812	10	VH-16R3645	11	VE-12R0845	12	VE-09R1290	12
CH-2006	10	VH-18R3645	11	VE-16R0845	12	VE-12R1290	12
CH-2009	10	VH-20R3645	11	VE-18R0845	12	VE-16R1290	12
CH-2012	10	VH-24R3645	11	VE-20R0845	12	VE-18R1290	12
CH-2406	10	VH-30R3645	11	VE-24R0845	12	VE-20R1290	12
CH-2409	10	VH-36R3645	11	VE-30R0845	12	VE-24R1290	12
CH-2412	10	VH-04R0890	11	VE-36R0845	12	VE-30R1290	12
CH-3006	10	VH-06R0890	11	VE-04R1245	12	VE-36R1290	12
CH-3009	10	VH-09R0890	11	VE-06R1245	12	VE-04R2490	12
CH-3012	10	VH-12R0890	11	VE-09R1245	12	VE-06R2490	12
CH-3606	10	VH-16R0890	11	VE-12R1245	12	VE-09R2490	12
CH-3609	10	VH-18R0890	11	VE-16R1245	12	VE-12R2490	12
CH-3612	10	VH-20R0890	11	VE-18R1245	12	VE-16R2490	12
		VH-24R0890	11	VE-20R1245	12	VE-18R2490	12
ACCESORIOS TIPO ESCALERA		VH-30R0890	11	VE-24R1245	12	VE-20R2490	12
VH-04R0845	11	VH-36R0890	11	VE-30R1245	12	VE-24R2490	12
VH-06R0845	11	VE-04R1290	11	VE-36R1245	12	VE-30R2490	12
VH-09R0845	11	VH-06R1290	11	VE-04R2445	12	VE-36R2490	12
VH-12R0845	11	VH-09R1290	11	VE-06R2445	12	VE-04R3690	12
VH-16R0845	11	VH-12R1290	11	VE-09R2445	12	VE-06R3690	12
VH-18R0845	11	VH-16R1290	11	VE-12R2445	12	VE-09R3690	12
VH-20R0845	11	VH-18R1290	11	VE-16R2445	12	VE-12R3690	12
VH-24R0845	11	VH-20R1290	11	VE-18R2445	12	VE-16R3690	12
VH-30R0845	11	VH-24R1290	11	VE-20R2445	12	VE-18R3690	12
VH-36R0845	11	VH-30R1290	11	VE-24R2445	12	VE-20R3690	12
VH-04R1245	11	VH-36R1290	11	VE-30R2445	12	VE-24R3690	12
VH-06R1245	11	VH-04R2490	11	VE-36R2445	12	VE-30R3690	12
VH-09R1245	11	VH-06R2490	11	VE-04R3645	12	VE-36R3690	12
VH-12R1245	11	VH-09R2490	11	VE-06R3645	12	VI-04R0845	13
VH-16R1245	11	VH-12R2490	11	VE-09R3645	12	VI-06R0845	13
VH-18R1245	11	VH-16R2490	11	VE-12R3645	12	VI-09R0845	13
VH-20R1245	11	VH-18R2490	11	VE-16R3645	12	VI-12R0845	13

INDICE POR No. DE CATALOGO

No. DE CAT.	PAG.	No. DE CAT.	PAG.	No. DE CAT.	PAG.	No. DE CAT.	PAG.
ACCESORIOS TIPO ESCALERA		ACCESORIOS TIPO ESCALERA		ACCESORIOS TIPO ESCALERA		ACCESORIOS TIPO ESCALERA	
VI-16R0845	13	VI-12R1290	13	TH-09R24	14	XH-06R36	15
VI-18R0845	13	VI-16R1290	13	TH-12R24	14	XH-09R36	15
VI-20R0845	13	VI-18R1290	13	TH-16R24	14	XH-12R36	15
VI-24R0845	13	VI-20R1290	13	TH-18R24	14	XH-16R36	15
VI-30R0845	13	VI-24R1290	13	TH-20R24	14	XH-18R36	15
VI-36R0845	13	VI-30R1290	13	TH-24R24	14	XH-20R36	15
VI-04R1245	13	VI-36R1290	13	TH-30R24	14	XH-24R36	15
VI-06R1245	13	VI-04R2490	13	TH-36R24	14	XH-30R36	15
VI-09R1245	13	VI-06R2490	13	TH-04R36	14	XH-36R36	15
VI-12R1245	13	VI-09R2490	13	TH-06R36	14	TV-04R08	16
VI-16R1245	13	VI-12R2490	13	TH-09R36	14	TV-06R08	16
VI-18R1245	13	VI-16R2490	13	TH-12R36	14	TV-09R08	16
VI-20R1245	13	VI-18R2490	13	TH-16R36	14	TV-12R08	16
VI-24R1245	13	VI-20R2490	13	TH-18R36	14	TV-16R08	16
VI-30R1245	13	VI-24R2490	13	TH-20R36	14	TV-18R08	16
VI-36R1245	13	VI-30R2490	13	TH-24R36	14	TV-20R08	16
VI-04R2445	13	VI-36R2490	13	TH-30R36	14	TV-24R08	16
VI-06R2445	13	VI-04R3690	13	TH-36R36	14	TV-30R08	16
VI-09R2445	13	VI-06R3690	13	XH-04R08	15	TV-36R08	16
VI-12R2445	13	VI-09R3690	13	XH-06R08	15	TV-04R12	16
VI-16R2445	13	VI-12R3690	13	XH-09R08	15	TV-06R12	16
VI-18R2445	13	VI-16R3690	13	XH-12R08	15	TV-09R12	16
VI-20R2445	13	VI-18R3690	13	XH-16R08	15	TV-12R12	16
VI-24R2445	13	VI-20R3690	13	XH-18R08	15	TV-16R12	16
VI-30R2445	13	VI-24R3690	13	XH-20R08	15	TV-18R12	16
VI-36R2445	13	VI-30R3690	13	XH-24R08	15	TV-20R12	16
VI-04R3645	13	VI-36R3690	13	XH-30R08	15	TV-24R12	16
VI-06R3645	13	TH-04R08	14	XH-36R08	15	TV-30R12	16
VI-09R3645	13	TH-06R08	14	XH-04R12	15	TV-36R12	16
VI-12R3645	13	TH-09R08	14	XH-06R12	15	TV-04R24	16
VI-16R3645	13	TH-12R08	14	XH-09R12	15	TV-06R24	16
VI-18R3645	13	TH-16R08	14	XH-12R12	15	TV-09R24	16
VI-20R3645	13	TH-18R08	14	XH-16R12	15	TV-12R24	16
VI-24R3645	13	TH-20R08	14	XH-18R12	15	TV-16R24	16
VI-30R3645	13	TH-24R08	14	XH-20R12	15	TV-18R24	16
VI-36R3645	13	TH-30R08	14	XH-24R12	15	TV-20R24	16
VI-04R0890	13	TH-36R08	14	XH-30R12	15	TV-24R24	16
VI-06R0890	13	TH-04R12	14	XH-36R12	15	TV-30R24	16
VI-09R0890	13	TH-06R12	14	XH-04R24	15	TV-36R24	16
VI-12R0890	13	TH-09R12	14	XH-06R24	15	TV-04R36	16
VI-16R0890	13	TH-12R12	14	XH-09R24	15	TV-06R36	16
VI-18R0890	13	TH-16R12	14	XH-12R24	15	TV-09R36	16
VI-20R0890	13	TH-18R12	14	XH-16R24	15	TV-12R36	16
VI-24R0890	13	TH-20R12	14	XH-18R24	15	TV-16R36	16
VI-30R0890	13	TH-24R12	14	XH-20R24	15	TV-18R36	16
VI-36R0890	13	TH-30R12	14	XH-24R24	15	TV-20R36	16
VI-04R1290	13	TH-36R12	14	XH-30R24	15	TV-24R36	16
VI-06R1290	13	TH-04R24	14	XH-36R24	15	TV-30R36	16
VI-09R1290	13	TH-06R24	14	XH-04R36	15	TV-36R36	16

INDICE POR No. DE CATALOGO

No. DE CAT.	PAG.	No. DE CAT.	PAG.	No. DE CAT.	PAG.	No. DE CAT.	PAG.
ACCESORIOS TIPO ESCALERA		ACCESORIOS TIPO ESCALERA		ACCESORIOS TIPO ESCALERA		ACCESORIOS TIPO ESCALERA	
XV-04R08	17	CA-36	18	RL-2006	19	RLI-1809	19
XV-06R08	17	DYZ-0445	18	RL-2004	19	RLI-1806	19
XV-09R08	17	DYZ-0645	18	RL-1816	19	RLI-1804	19
XV-12R08	17	DYZ-0945	18	RL-1812	19	RLI-1612	19
XV-16R08	17	DYZ-1245	18	RL-1809	19	RLI-1609	19
XV-18R08	17	DYZ-1645	18	RL-1806	19	RLI-1606	19
XV-20R08	17	DYZ-1845	18	RL-1804	19	RLI-1604	19
XV-24R08	17	DYZ-2045	18	RL-1612	19	RLI-1209	19
XV-30R08	17	DYZ-2445	18	RL-1609	19	RLI-1206	19
XV-36R08	17	DYZ-3045	18	RL-1606	19	RLI-1204	19
XV-04R12	17	DYZ-3645	18	RL-1604	19	RLI-0906	19
XV-06R12	17	DYD-0445	18	RL-1209	19	RLI-0904	19
XV-09R12	17	DYD-0645	18	RL-1206	19	RLI-0604	19
XV-12R12	17	DYD-0945	18	RL-1204	19	RLD-3630	19
XV-16R12	17	DYD-1245	18	RL-0906	19	RLD-3624	19
XV-18R12	17	DYD-1645	18	RL-0904	19	RLD-3620	19
XV-20R12	17	DYD-1845	18	RL-0604	19	RLD-3618	19
XV-24R12	17	DYD-2045	18	RLI-3630	19	RLD-3616	19
XV-30R12	17	DYD-2445	18	RLI-3624	19	RLD-3612	19
XV-36R12	17	DYD-3045	18	RLI-3620	19	RLD-3609	19
XV-04R24	17	DYD-3645	18	RLI-3618	19	RLD-3606	19
XV-06R24	17	RL-3630	19	RLI-3616	19	RLD-3604	19
XV-09R24	17	RL-3624	19	RLI-3612	19	RLD-3024	19
XV-12R24	17	RL-3620	19	RLI-3609	19	RLD-3020	19
XV-16R24	17	RL-3618	19	RLI-3606	19	RLD-3018	19
XV-18R24	17	RL-3616	19	RLI-3604	19	RLD-3016	19
XV-20R24	17	RL-3612	19	RLI-3024	19	RLD-3012	19
XV-24R24	17	RL-3609	19	RLI-3020	19	RLD-3009	19
XV-30R24	17	RL-3606	19	RLI-3018	19	RLD-3006	19
XV-36R24	17	RL-3604	19	RLI-3016	19	RLD-3004	19
XV-04R36	17	RL-3024	19	RLI-3012	19	RLD-2420	19
XV-06R36	17	RL-3020	19	RLI-3009	19	RLD-2418	19
XV-09R36	17	RL-3018	19	RLI-3006	19	RLD-2416	19
XV-12R36	17	RL-3016	19	RLI-3004	19	RLD-2412	19
XV-16R36	17	RL-3012	19	RLI-2420	19	RLD-2409	19
XV-18R36	17	RL-3009	19	RLI-2418	19	RLD-2406	19
XV-20R36	17	RL-3006	19	RLI-2416	19	RLD-2404	19
XV-24R36	17	RL-3004	19	RLI-2412	19	RLD-2018	19
XV-30R36	17	RL-2420	19	RLI-2409	19	RLD-2016	19
XV-36R36	17	RL-2418	19	RLI-2406	19	RLD-2012	19
CA-04	18	RL-2416	19	RLI-2404	19	RLD-2009	19
CA-06	18	RL-2412	19	RLI-2018	19	RLD-2006	19
CA-09	18	RL-2409	19	RLI-2016	19	RLD-2004	19
CA-12	18	RL-2406	19	RLI-2012	19	RLD-1816	19
CA-16	18	RL-2404	19	RLI-2009	19	RLD-1812	19
CA-18	18	RL-2018	19	RLI-2006	19	RLD-1809	19
CA-20	18	RL-2016	19	RLI-2004	19	RLD-1806	19
CA-24	18	RL-2012	19	RLI-1816	19	RLD-1804	19
CA-30	18	RL-2009	19	RLI-1812	19	RLD-1612	19

INDICE POR No. DE CATALOGO

No. DE CAT.	PAG.	No. DE CAT.	PAG.	No. DE CAT.	PAG.	No. DE CAT.	PAG.
ACCESORIOS TIPO ESCALERA		ACCESORIO PERFIL I LIGERO		ACCESORIO PERFIL I LIGERO		ACCESORIO PERFIL I LIGERO	
RLD-1609	19	VHIL-20R0845	11	VHIL-18R1290	11	VEIL-16R2445	12
RLD-1606	19	VHIL-24R0845	11	VHIL-20R1290	11	VEIL-18R2445	12
RLD-1604	19	VHIL-30R0845	11	VHIL-24R1290	11	VEIL-20R2445	12
RLD-1209	19	VHIL-36R0845	11	VHIL-30R1290	11	VEIL-24R2445	12
RLD-1206	19	VHIL-04R1245	11	VHIL-36R1290	11	VEIL-30R2445	12
RLD-1204	19	VHIL-06R1245	11	VHIL-04R2490	11	VEIL-36R2445	12
RLD-0906	19	VHIL-09R1245	11	VHIL-06R2490	11	VEIL-04R3645	12
RLD-0904	19	VHIL-12R1245	11	VHIL-09R2490	11	VEIL-06R3645	12
RLD-0604	19	VHIL-16R1245	11	VHIL-12R2490	11	VEIL-09R3645	12
		VHIL-18R1245	11	VHIL-16R2490	11	VEIL-12R3645	12
CHAROLA PERFIL I LIGERO		VHIL-20R1245	11	VHIL-18R2490	11	VEIL-16R3645	12
CHIL-0406	10	VHIL-24R1245	11	VHIL-20R2490	11	VEIL-18R3645	12
CHIL-0409	10	VHIL-30R1245	11	VHIL-24R2490	11	VEIL-20R3645	12
CHIL-0412	10	VHIL-36R1245	11	VHIL-30R2490	11	VEIL-24R3645	12
CHIL-0606	10	VHIL-04R2445	11	VHIL-36R2490	11	VEIL-30R3645	12
CHIL-0609	10	VHIL-06R2445	11	VHIL-04R3690	11	VEIL-36R3645	12
CHIL-0612	10	VHIL-09R2445	11	VHIL-06R3690	11	VEIL-04R0890	12
CHIL-0906	10	VHIL-12R2445	11	VHIL-09R3690	11	VEIL-06R0890	12
CHIL-0909	10	VHIL-16R2445	11	VHIL-12R3690	11	VEIL-09R0890	12
CHIL-0912	10	VHIL-18R2445	11	VHIL-16R3690	11	VEIL-12R0890	12
CHIL-1206	10	VHIL-20R2445	11	VHIL-18R3690	11	VEIL-16R0890	12
CHIL-1209	10	VHIL-24R2445	11	VHIL-20R3690	11	VEIL-18R0890	12
CHIL-1212	10	VHIL-30R2445	11	VHIL-24R3690	11	VEIL-20R0890	12
CHIL-1606	10	VHIL-36R2445	11	VHIL-30R3690	11	VEIL-24R0890	12
CHIL-1609	10	VHIL-04R3645	11	VHIL-36R3690	11	VEIL-30R0890	12
CHIL-1612	10	VHIL-06R3645	11	VEIL-04R0845	12	VEIL-36R0890	12
CHIL-1806	10	VHIL-09R3645	11	VEIL-06R0845	12	VEIL-04R1290	12
CHIL-1809	10	VHIL-12R3645	11	VEIL-09R0845	12	VEIL-06R1290	12
CHIL-1812	10	VHIL-16R3645	11	VEIL-12R0845	12	VEIL-09R1290	12
CHIL-2006	10	VHIL-18R3645	11	VEIL-16R0845	12	VEIL-12R1290	12
CHIL-2009	10	VHIL-20R3645	11	VEIL-18R0845	12	VEIL-16R1290	12
CHIL-2012	10	VHIL-24R3645	11	VEIL-20R0845	12	VEIL-18R1290	12
CHIL-2406	10	VHIL-30R3645	11	VEIL-24R0845	12	VEIL-20R1290	12
CHIL-2409	10	VHIL-36R3645	11	VEIL-30R0845	12	VEIL-24R1290	12
CHIL-2412	10	VHIL-04R0890	11	VEIL-36R0845	12	VEIL-30R1290	12
CHIL-3006	10	VHIL-06R0890	11	VEIL-04R1245	12	VEIL-36R1290	12
CHIL-3009	10	VHIL-09R0890	11	VEIL-06R1245	12	VEIL-04R2490	12
CHIL-3012	10	VHIL-12R0890	11	VEIL-09R1245	12	VEIL-06R2490	12
CHIL-3606	10	VHIL-16R0890	11	VEIL-12R1245	12	VEIL-09R2490	12
CHIL-3609	10	VHIL-18R0890	11	VEIL-16R1245	12	VEIL-12R2490	12
CHIL-3612	10	VHIL-20R0890	11	VEIL-18R1245	12	VEIL-16R2490	12
		VHIL-24R0890	11	VEIL-20R1245	12	VEIL-18R2490	12
ACCESORIO PERFIL I LIGERO		VHIL-30R0890	11	VEIL-24R1245	12	VEIL-20R2490	12
VHIL-04R0845	11	VHIL-36R0890	11	VEIL-30R1245	12	VEIL-24R2490	12
VHIL-06R0845	11	VHIL-04R1290	11	VEIL-36R1245	12	VEIL-30R2490	12
VHIL-09R0845	11	VHIL-06R1290	11	VEIL-04R2445	12	VEIL-36R2490	12
VHIL-12R0845	11	VHIL-09R1290	11	VEIL-06R2445	12	VEIL-04R3690	12
VHIL-16R0845	11	VHIL-12R1290	11	VEIL-09R2445	12	VEIL-06R3690	12
VHIL-18R0845	11	VHIL-16R1290	11	VEIL-12R2445	12	VEIL-09R3690	12

INDICE POR No. DE CATALOGO

No. DE CAT.	PAG.	No. DE CAT.	PAG.	No. DE CAT.	PAG.	No. DE CAT.	PAG.
ACCESORIO PERFIL I LIGERO		ACCESORIO PERFIL I LIGERO		ACCESORIO PERFIL I LIGERO		ACCESORIO PERFIL I LIGERO	
VEIL-12R3690	12	VIII-09R0890	13	THIL-06R12	14	XHIL-04R24	15
VEIL-16R3690	12	VIII-12R0890	13	THIL-09R12	14	XHIL-06R24	15
VEIL-18R3690	12	VIII-16R0890	13	THIL-12R12	14	XHIL-09R24	15
VEIL-20R3690	12	VIII-18R0890	13	THIL-16R12	14	XHIL-12R24	15
VEIL-24R3690	12	VIII-20R0890	13	THIL-18R12	14	XHIL-16R24	15
VEIL-30R3690	12	VIII-24R0890	13	THIL-20R12	14	XHIL-18R24	15
VEIL-36R3690	12	VIII-30R0890	13	THIL-24R12	14	XHIL-20R24	15
VIII-04R0845	13	VIII-36R0890	13	THIL-30R12	14	XHIL-24R24	15
VIII-06R0845	13	VIII-04R1290	13	THIL-36R12	14	XHIL-30R24	15
VIII-09R0845	13	VIII-06R1290	13	THIL-04R24	14	XHIL-36R24	15
VIII-12R0845	13	VIII-09R1290	13	THIL-06R24	14	XHIL-04R36	15
VIII-16R0845	13	VIII-12R1290	13	THIL-09R24	14	XHIL-06R36	15
VIII-18R0845	13	VIII-16R1290	13	THIL-12R24	14	XHIL-09R36	15
VIII-20R0845	13	VIII-18R1290	13	THIL-16R24	14	XHIL-12R36	15
VIII-24R0845	13	VIII-20R1290	13	THIL-18R24	14	XHIL-16R36	15
VIII-30R0845	13	VIII-24R1290	13	THIL-20R24	14	XHIL-18R36	15
VIII-36R0845	13	VIII-30R1290	13	THIL-24R24	14	XHIL-20R36	15
VIII-04R1245	13	VIII-36R1290	13	THIL-30R24	14	XHIL-24R36	15
VIII-06R1245	13	VIII-04R2490	13	THIL-36R24	14	XHIL-30R36	15
VIII-09R1245	13	VIII-06R2490	13	THIL-04R36	14	XHIL-36R36	15
VIII-12R1245	13	VIII-09R2490	13	THIL-06R36	14	TVIL-04R08	16
VIII-16R1245	13	VIII-12R2490	13	THIL-09R36	14	TVIL-06R08	16
VIII-18R1245	13	VIII-16R2490	13	THIL-12R36	14	TVIL-09R08	16
VIII-20R1245	13	VIII-18R2490	13	THIL-16R36	14	TVIL-12R08	16
VIII-24R1245	13	VIII-20R2490	13	THIL-18R36	14	TVIL-16R08	16
VIII-30R1245	13	VIII-24R2490	13	THIL-20R36	14	TVIL-18R08	16
VIII-36R1245	13	VIII-30R2490	13	THIL-24R36	14	TVIL-20R08	16
VIII-04R2445	13	VIII-36R2490	13	THIL-30R36	14	TVIL-24R08	16
VIII-06R2445	13	VIII-04R3690	13	THIL-36R36	14	TVIL-30R08	16
VIII-09R2445	13	VIII-06R3690	13	XHIL-04R08	15	TVIL-36R08	16
VIII-12R2445	13	VIII-09R3690	13	XHIL-06R08	15	TVIL-04R12	16
VIII-16R2445	13	VIII-12R3690	13	XHIL-09R08	15	TVIL-06R12	16
VIII-18R2445	13	VIII-16R3690	13	XHIL-12R08	15	TVIL-09R12	16
VIII-20R2445	13	VIII-18R2490	13	XHIL-16R08	15	TVIL-12R12	16
VIII-24R2445	13	VIII-20R3690	13	XHIL-18R08	15	TVIL-16R12	16
VIII-30R2445	13	VIII-24R3690	13	XHIL-20R08	15	TVIL-18R12	16
VIII-36R2445	13	VIII-30R3690	13	XHIL-24R08	15	TVIL-20R12	16
VIII-04R3645	13	VIII-36R3690	13	XHIL-30R08	15	TVIL-24R12	16
VIII-06R3645	13	THIL-04R08	14	XHIL-36R08	15	TVIL-30R12	16
VIII-09R3645	13	THIL-06R08	14	XHIL-04R12	15	TVIL-36R12	16
VIII-12R3645	13	THIL-09R08	14	XHIL-06R12	15	TVIL-04R24	16
VIII-16R3645	13	THIL-12R08	14	XHIL-09R12	15	TVIL-06R24	16
VIII-18R3645	13	THIL-16R08	14	XHIL-12R12	15	TVIL-09R24	16
VIII-20R3645	13	THIL-18R08	14	XHIL-16R12	15	TVIL-12R24	16
VIII-24R3645	13	THIL-20R08	14	XHIL-18R12	15	TVIL-16R24	16
VIII-30R3645	13	THIL-24R08	14	XHIL-20R12	15	TVIL-18R24	16
VIII-36R3645	13	THIL-30R08	14	XHIL-24R12	15	TVIL-20R24	16
VIII-04R0890	13	THIL-36R08	14	XHIL-30R12	15	TVIL-24R24	16
VIII-06R0890	13	THIL-04R12	14	XHIL-36R12	15	TVIL-30R24	16

INDICE POR No. DE CATALOGO

No. DE CAT.	PAG.	No. DE CAT.	PAG.	No. DE CAT.	PAG.	No. DE CAT.	PAG.
ACCESORIO PERFIL I LIGERO		ACCESORIO PERFIL I LIGERO		ACCESORIO PERFIL I LIGERO		ACCESORIO PERFIL I LIGERO	
TVIL-36R24	16	XVIL-30R36	17	RLIL-2420	19	RLDIL-2409	19
TVIL-04R36	16	XVIL-36R36	17	RLIL-2418	19	RLDIL-2406	19
TVIL-06R36	16	CAIL-04	18	RLIL-2416	19	RLDIL-2404	19
TVIL-09R36	16	CAIL-06	18	RLIL-2412	19	RLDIL-2018	19
TVIL-12R36	16	CAIL-09	18	RLIL-2409	19	RLDIL-2016	19
TVIL-16R36	16	CAIL-12	18	RLIL-2406	19	RLDIL-2012	19
TVIL-18R36	16	CAIL-16	18	RLIL-2404	19	RLDIL-2009	19
TVIL-20R36	16	CAIL-18	18	RLIL-2018	19	RLDIL-2006	19
TVIL-24R36	16	CAIL-20	18	RLIL-2016	19	RLDIL-2004	19
TVIL-30R36	16	CAIL-24	18	RLIL-2012	19	RLDIL-1816	19
TVIL-36R36	16	CAIL-30	18	RLIL-2009	19	RLDIL-1812	19
XVIL-04R08	17	CAIL-36	18	RLIL-2006	19	RLDIL-1809	19
XVIL-06R08	17	DYZIL-0445	18	RLIL-2004	19	RLDIL-1806	19
XVIL-09R08	17	DYZIL-0645	18	RLIL-1816	19	RLDIL-1804	19
XVIL-12R08	17	DYZIL-0945	18	RLIL-1812	19	RLDIL-1612	19
XVIL-16R08	17	DYZIL-1245	18	RLIL-1809	19	RLDIL-1609	19
XVIL-18R08	17	DYZIL-1645	18	RLIL-1806	19	RLDIL-1606	19
XVIL-20R08	17	DYZIL-1845	18	RLIL-1804	19	RLDIL-1604	19
XVIL-24R08	17	DYZIL-2045	18	RLIL-1612	19	RLDIL-1209	19
XVIL-30R08	17	DYZIL-2445	18	RLIL-1609	19	RLDIL-1206	19
XVIL-36R08	17	DYZIL-3045	18	RLIL-1606	19	RLDIL-1204	19
XVIL-04R12	17	DYZIL-3645	18	RLIL-1604	19	RLDIL-0906	19
XVIL-06R12	17	DYDIL-0445	18	RLIL-1209	19	RLDIL-0904	19
XVIL-09R12	17	DYDIL-0645	18	RLIL-1206	19	RLDIL-0604	19
XVIL-12R12	17	DYDIL-0945	18	RLIL-1204	19	RLIL-3630	19
XVIL-16R12	17	DYDIL-1245	18	RLIL-0906	19	RLIL-3624	19
XVIL-18R12	17	DYDIL-1645	18	RLIL-0904	19	RLIL-3620	19
XVIL-20R12	17	DYDIL-1845	18	RLIL-0604	19	RLIL-3618	19
XVIL-24R12	17	DYDIL-2045	18	RLDIL-3630	19	RLIL-3616	19
XVIL-30R12	17	DYDIL-2445	18	RLDIL-3624	19	RLIL-3612	19
XVIL-36R12	17	DYDIL-3045	18	RLDIL-3620	19	RLIL-3609	19
XVIL-04R24	17	DYDIL-3645	18	RLDIL-3618	19	RLIL-3606	19
XVIL-06R24	17	RLIL-3630	19	RLDIL-3616	19	RLIL-3604	19
XVIL-09R24	17	RLIL-3624	19	RLDIL-3612	19	RLIL-3024	19
XVIL-12R24	17	RLIL-3620	19	RLDIL-3609	19	RLIL-3020	19
XVIL-16R24	17	RLIL-3618	19	RLDIL-3606	19	RLIL-3018	19
XVIL-18R24	17	RLIL-3616	19	RLDIL-3604	19	RLIL-3016	19
XVIL-20R24	17	RLIL-3612	19	RLDIL-3024	19	RLIL-3012	19
XVIL-24R24	17	RLIL-3609	19	RLDIL-3020	19	RLIL-3009	19
XVIL-30R24	17	RLIL-3606	19	RLDIL-3018	19	RLIL-3006	19
XVIL-36R24	17	RLIL-3604	19	RLDIL-3016	19	RLIL-3004	19
XVIL-04R36	17	RLIL-3024	19	RLDIL-3012	19	RLIL-2420	19
XVIL-06R36	17	RLIL-3020	19	RLDIL-3009	19	RLIL-2418	19
XVIL-09R36	17	RLIL-3018	19	RLDIL-3006	19	RLIL-2416	19
XVIL-12R36	17	RLIL-3016	19	RLDIL-3004	19	RLIL-2412	19
XVIL-16R36	17	RLIL-3012	19	RLDIL-2420	19	RLIL-2409	19
XVIL-18R36	17	RLIL-3009	19	RLDIL-2418	19	RLIL-2406	19
XVIL-20R36	17	RLIL-3006	19	RLDIL-2416	19	RLIL-2404	19
XVIL-24R36	17	RLIL-3004	19	RLDIL-2412	19	RLIL-2018	19

INDICE POR No. DE CATALOGO

No. DE CAT.	PAG.	No. DE CAT.	PAG.	No. DE CAT.	PAG.	No. DE CAT.	PAG.
ACCESORIO PERFIL I LIGERO		CHAROLA PERFIL I MEDIANO		ACCESORIO PERFIL I MEDIANO		ACCESORIO PERFIL I MEDIANO	
RLIIL-2016	19	CHIM-3606	10	VHIM-16R0890	11	VEIM-12R1245	12
RLIIL-2012	19	CHIM-3609	10	VHIM-18R0890	11	VEIM-16R1245	12
RLIIL-2009	19	CHIM-3612	10	VHIM-20R0890	11	VEIM-18R1245	12
RLIIL-2006	19			VHIM-24R0890	11	VEIM-20R1245	12
RLIIL-2004	19	ACCESORIO PERFIL I MEDIANO		VHIM-30R0890	11	VEIM-24R1245	12
RLIIL-1816	19	VHIM-04R0845	11	VHIM-36R0890	11	VEIM-30R1245	12
RLIIL-1812	19	VHIM-06R0845	11	VHIM-04R1290	11	VEIM-18R1245	12
RLIIL-1809	19	VHIM-09R0845	11	VHIM-06R1290	11	VEIM-04R2445	12
RLIIL-1806	19	VHIM-12R0845	11	VHIM-09R1290	11	VEIM-06R2445	12
RLIIL-1804	19	VHIM-16R0845	11	VHIM-12R1290	11	VEIM-09R2445	12
RLIIL-1612	19	VHIM-18R0845	11	VHIM-16R1290	11	VEIM-12R2445	12
RLIIL-1609	19	VHIM-20R0845	11	VHIM-18R1290	11	VEIM-16R2445	12
RLIIL-1606	19	VHIM-24R0845	11	VHIM-20R1290	11	VEIM-18R2445	12
RLIIL-1604	19	VHIM-30R0845	11	VHIM-24R1290	11	VEIM-20R2445	12
RLIIL-1209	19	VHIM-36R0845	11	VHIM-30R1290	11	VEIM-24R2445	12
RLIIL-1206	19	VHIM-04R1245	11	VHIM-36R1290	11	VEIM-30R2445	12
RLIIL-1204	19	VHIM-06R1245	11	VHIM-04R2490	11	VEIM-36R2445	12
RLIIL-0906	19	VHIM-09R1245	11	VHIM-06R2490	11	VEIM-04R3645	12
RLIIL-0904	19	VHIM-12R1245	11	VHIM-09R2490	11	VEIM-06R3645	12
RLIIL-0604	19	VHIM-16R1245	11	VHIM-12R2490	11	VEIM-09R3645	12
		VHIM-18R1245	11	VHIM-16R2490	11	VEIM-12R3645	12
CHAROLA PERFIL I MEDIANO		VHIM-20R1245	11	VHIM-18R2490	11	VEIM-16R3645	12
CHIM-0406	10	VHIM-24R1245	11	VHIM-20R2490	11	VEIM-18R3645	12
CHIM-0409	10	VHIM-30R1245	11	VHIM-24R2490	11	VEIM-20R3645	12
CHIM-0412	10	VHIM-36R1245	11	VHIM-30R2490	11	VEIM-24R3645	12
CHIM-0606	10	VHIM-04R2445	11	VHIM-36R2490	11	VEIM-30R3645	12
CHIM-0609	10	VHIM-06R2445	11	VHIM-04R3690	11	VEIM-36R3645	12
CHIM-0612	10	VHIM-09R2445	11	VHIM-06R3690	11	VEIM-04R0890	12
CHIM-0906	10	VHIM-12R2445	11	VHIM-09R3690	11	VEIM-06R0890	12
CHIM-0909	10	VHIM-16R2445	11	VHIM-12R3690	11	VEIM-09R0890	12
CHIM-0912	10	VHIM-18R2445	11	VHIM-16R3690	11	VEIM-12R0890	12
CHIM-1206	10	VHIM-20R2445	11	VHIM-18R3690	11	VEIM-16R0890	12
CHIM-1209	10	VHIM-24R2445	11	VHIM-20R3690	11	VEIM-18R0890	12
CHIM-1212	10	VHIM-30R2445	11	VHIM-24R3690	11	VEIM-20R0890	12
CHIM-1606	10	VHIM-36R2445	11	VHIM-30R3690	11	VEIM-24R0890	12
CHIM-1609	10	VHIM-04R3645	11	VHIM-36R3690	11	VEIM-30R0890	12
CHIM-1612	10	VHIM-06R3645	11	VEIM-04R0845	12	VEIM-36R0890	12
CHIM-1806	10	VHIM-09R3645	11	VEIM-06R0845	12	VEIM-04R1290	12
CHIM-1809	10	VHIM-12R3645	11	VEIM-09R0845	12	VEIM-06R1290	12
CHIM-1812	10	VHIM-16R3645	11	VEIM-12R0845	12	VEIM-09R1290	12
CHIM-2006	10	VHIM-18R3645	11	VEIM-16R0845	12	VEIM-12R1290	12
CHIM-2009	10	VHIM-20R3645	11	VEIM-18R0845	12	VEIM-16R1290	12
CHIM-2012	10	VHIM-24R3645	11	VEIM-20R0845	12	VEIM-18R1290	12
CHIM-2406	10	VHIM-30R3645	11	VEIM-24R0845	12	VEIM-20R1290	12
CHIM-2409	10	VHIM-36R3645	11	VEIM-30R0845	12	VEIM-24R1290	12
CHIM-2412	10	VHIM-04R0890	11	VEIM-36R0845	12	VEIM-30R1290	12
CHIM-3006	10	VHIM-06R0890	11	VEIM-04R1245	12	VEIM-36R1290	12
CHIM-3009	10	VHIM-09R0890	11	VEIM-06R1245	12	VEIM-04R2490	12
CHIM-3012	10	VHIM-12R0890	11	VEIM-09R1245	12	VEIM-06R2490	12

INDICE POR No. DE CATALOGO

No. DE CAT.	PAG.	No. DE CAT.	PAG.	No. DE CAT.	PAG.	No. DE CAT.	PAG.
ACCESORIO PERFIL I MEDIANO		ACCESORIO PERFIL I MEDIANO		ACCESORIO PERFIL I MEDIANO		ACCESORIO PERFIL I MEDIANO	
VEIM-09R2490	12	VIIIM-06R3645	13	THIM-04R08	14	XHIM-36R08	15
VEIM-12R2490	12	VIIIM-09R3645	13	THIM-06R08	14	XHIM-04R12	15
VEIM-16R2490	12	VIIIM-12R3645	13	THIM-09R08	14	XHIM-06R12	15
VEIM-18R2490	12	VIIIM-16R3645	13	THIM-12R08	14	XHIM-09R12	15
VEIM-20R2490	12	VIIIM-18R3645	13	THIM-16R08	14	XHIM-12R12	15
VEIM-24R2490	12	VIIIM-20R3645	13	THIM-18R08	14	XHIM-16R12	15
VEIM-30R2490	12	VIIIM-24R3645	13	THIM-20R08	14	XHIM-18R12	15
VEIM-36R2490	12	VIIIM-30R3645	13	THIM-24R08	14	XHIM-20R12	15
VEIM-04R3690	12	VIIIM-36R3645	13	THIM-30R08	14	XHIM-24R12	15
VEIM-06R3690	12	VIIIM-04R0890	13	THIM-36R08	14	XHIM-30R12	15
VEIM-09R3690	12	VIIIM-06R0890	13	THIM-04R12	14	XHIM-36R12	15
VEIM-12R3690	12	VIIIM-09R0890	13	THIM-06R12	14	XHIM-04R24	15
VEIM-16R3690	12	VIIIM-12R0890	13	THIM-09R12	14	XHIM-06R24	15
VEIM-18R3690	12	VIIIM-16R0890	13	THIM-12R12	14	XHIM-09R24	15
VEIM-20R3690	12	VIIIM-18R0890	13	THIM-16R12	14	XHIM-12R24	15
VEIM-24R3690	12	VIIIM-20R0890	13	THIM-18R12	14	XHIM-16R24	15
VEIM-30R3690	12	VIIIM-24R0890	13	THIM-20R12	14	XHIM-18R24	15
VEIM-36R3690	12	VIIIM-30R0890	13	THIM-24R12	14	XHIM-20R24	15
VIIIM-04R0845	13	VIIIM-36R0890	13	THIM-30R12	14	XHIM-24R24	15
VIIIM-06R0845	13	VIIIM-04R1290	13	THIM-36R12	14	XHIM-30R24	15
VIIIM-09R0845	13	VIIIM-06R1290	13	THIM-04R24	14	XHIM-36R24	15
VIIIM-12R0845	13	VIIIM-09R1290	13	THIM-06R24	14	XHIM-04R36	15
VIIIM-16R0845	13	VIIIM-12R1290	13	THIM-09R24	14	XHIM-06R36	15
VIIIM-18R0845	13	VIIIM-16R1290	13	THIM-12R24	14	XHIM-09R36	15
VIIIM-20R0845	13	VIIIM-18R1290	13	THIM-16R24	14	XHIM-12R36	15
VIIIM-24R0845	13	VIIIM-20R1290	13	THIM-18R24	14	XHIM-16R36	15
VIIIM-30R0845	13	VIIIM-24R1290	13	THIM-20R24	14	XHIM-18R36	15
VIIIM-36R0845	13	VIIIM-30R1290	13	THIM-24R24	14	XHIM-20R36	15
VIIIM-04R1245	13	VIIIM-36R1290	13	THIM-30R24	14	XHIM-24R36	15
VIIIM-06R1245	13	VIIIM-04R2490	13	THIM-36R24	14	XHIM-30R36	15
VIIIM-09R1245	13	VIIIM-06R2490	13	THIM-04R36	14	XHIM-36R36	15
VIIIM-12R1245	13	VIIIM-09R2490	13	THIM-06R36	14	TVIM-04R08	16
VIIIM-16R1245	13	VIIIM-12R2490	13	THIM-09R36	14	TVIM-06R08	16
VIIIM-18R1245	13	VIIIM-16R2490	13	THIM-12R36	14	TVIM-09R08	16
VIIIM-20R1245	13	VIIIM-18R2490	13	THIM-16R36	14	TVIM-12R08	16
VIIIM-24R1245	13	VIIIM-20R2490	13	THIM-18R36	14	TVIM-16R08	16
VIIIM-30R1245	13	VIIIM-24R2490	13	THIM-20R36	14	TVIM-18R08	16
VIIIM-36R1245	13	VIIIM-30R2490	13	THIM-24R36	14	TVIM-20R08	16
VIIIM-04R2445	13	VIIIM-36R2490	13	THIM-30R36	14	TVIM-24R08	16
VIIIM-06R2445	13	VIIIM-04R3690	13	THIM-36R36	14	TVIM-30R08	16
VIIIM-09R2445	13	VIIIM-06R3690	13	XHIM-04R08	15	TVIM-36R08	16
VIIIM-12R2445	13	VIIIM-09R3690	13	XHIM-06R08	15	TVIM-04R12	16
VIIIM-16R2445	13	VIIIM-12R3690	13	XHIM-09R08	15	TVIM-06R12	16
VIIIM-18R2445	13	VIIIM-16R3690	13	XHIM-12R08	15	TVIM-09R12	16
VIIIM-20R2445	13	VIIIM-18R3690	13	XHIM-16R08	15	TVIM-12R12	16
VIIIM-24R2445	13	VIIIM-20R3690	13	XHIM-18R08	15	TVIM-16R12	16
VIIIM-30R2445	13	VIIIM-24R3690	13	XHIM-20R08	15	TVIM-18R12	16
VIIIM-36R2445	13	VIIIM-30R3690	13	XHIM-24R08	15	TVIM-20R12	16
VIIIM-04R3645	13	VIIIM-36R3690	13	XHIM-30R08	15	TVIM-24R12	16

INDICE POR No. DE CATALOGO

No. DE CAT.	PAG.	No. DE CAT.	PAG.	No. DE CAT.	PAG.	No. DE CAT.	PAG.
ACCESORIO PERFIL I MEDIANO		ACCESORIO PERFIL I MEDIANO		ACCESORIO PERFIL I MEDIANO		ACCESORIO PERFIL I MEDIANO	
TVIM-30R12	16	XVIM-24R24	17	RLIM-3609	19	RLDIM-3020	19
TVIM-36R12	16	XVIM-30R24	17	RLIM-3606	19	RLDIM-3018	19
TVIM-04R24	16	XVIM-36R24	17	RLIM-3604	19	RLDIM-3016	19
TVIM-06R24	16	XVIM-04R36	17	RLIM-3024	19	RLDIM-3012	19
TVIM-09R24	16	XVIM-06R36	17	RLIM-3020	19	RLDIM-3009	19
TVIM-12R24	16	XVIM-09R36	17	RLIM-3018	19	RLDIM-3006	19
TVIM-16R24	16	XVIM-12R36	17	RLIM-3016	19	RLDIM-3004	19
TVIM-18R24	16	XVIM-16R36	17	RLIM-3012	19	RLDIM-2420	19
TVIM-20R24	16	XVIM-18R36	17	RLIM-3009	19	RLDIM-2418	19
TVIM-24R24	16	XVIM-20R36	17	RLIM-3006	19	RLDIM-2416	19
TVIM-30R24	16	XVIM-24R36	17	RLIM-3004	19	RLDIM-2412	19
TVIM-36R24	16	XVIM-30R36	17	RLIM-2420	19	RLDIM-2409	19
TVIM-04R36	16	XVIM-36R36	17	RLIM-2418	19	RLDIM-2406	19
TVIM-06R36	16	CAIM-04	18	RLIM-2416	19	RLDIM-2404	19
TVIM-09R36	16	CAIM-06	18	RLIM-2412	19	RLDIM-2018	19
TVIM-12R36	16	CAIM-09	18	RLIM-2409	19	RLDIM-2016	19
TVIM-16R36	16	CAIM-12	18	RLIM-2406	19	RLDIM-2012	19
TVIM-18R36	16	CAIM-16	18	RLIM-2404	19	RLDIM-2009	19
TVIM-20R36	16	CAIM-18	18	RLIM-2018	19	RLDIM-2006	19
TVIM-24R36	16	CAIM-20	18	RLIM-2016	19	RLDIM-2004	19
TVIM-30R36	16	CAIM-24	18	RLIM-2012	19	RLDIM-1816	19
TVIM-36R36	16	CAIM-30	18	RLIM-2009	19	RLDIM-1812	19
XVIM-04R08	17	CAIM-36	18	RLIM-2006	19	RLDIM-1809	19
XVIM-06R08	17	DYZIM-0445	18	RLIM-2004	19	RLDIM-1806	19
XVIM-09R08	17	DYZIM-0645	18	RLIM-1816	19	RLDIM-1804	19
XVIM-12R08	17	DYZIM-0945	18	RLIM-1812	19	RLDIM-1612	19
XVIM-16R08	17	DYZIM-1245	18	RLIM-1809	19	RLDIM-1609	19
XVIM-18R08	17	DYZIM-1645	18	RLIM-1806	19	RLDIM-1606	19
XVIM-20R08	17	DYZIM-1845	18	RLIM-1804	19	RLDIM-1604	19
XVIM-24R08	17	DYZIM-2045	18	RLIM-1612	19	RLDIM-1209	19
XVIM-30R08	17	DYZIM-2445	18	RLIM-1609	19	RLDIM-1206	19
XVIM-36R08	17	DYZIM-3045	18	RLIM-1606	19	RLDIM-1204	19
XVIM-04R12	17	DYZIM-3645	18	RLIM-1604	19	RLDIM-0906	19
XVIM-06R12	17	DYDIM-0445	18	RLIM-1209	19	RLDIM-0904	19
XVIM-09R12	17	DYDIM-0645	18	RLIM-1206	19	RLDIM-0604	19
XVIM-12R12	17	DYDIM-0945	18	RLIM-1204	19	RLIIM-3630	19
XVIM-16R12	17	DYDIM-1245	18	RLIM-0906	19	RLIIM-3624	19
XVIM-18R12	17	DYDIM-1645	18	RLIM-0904	19	RLIIM-3620	19
XVIM-20R12	17	DYDIM-1845	18	RLIM-0604	19	RLIIM-3618	19
XVIM-24R12	17	DYDIM-2045	18	RLDIM-3630	19	RLIIM-3616	19
XVIM-30R12	17	DYDIM-2445	18	RLDIM-3624	19	RLIIM-3612	19
XVIM-36R12	17	DYDIM-3045	18	RLDIM-3620	19	RLIIM-3609	19
XVIM-04R24	17	DYDIM-3645	18	RLDIM-3618	19	RLIIM-3606	19
XVIM-06R24	17	RLIM-3630	19	RLDIM-3616	19	RLIIM-3604	19
XVIM-09R24	17	RLIM-3624	19	RLDIM-3612	19	RLIIM-3024	19
XVIM-12R24	17	RLIM-3620	19	RLDIM-3609	19	RLIIM-3020	19
XVIM-16R24	17	RLIM-3618	19	RLDIM-3606	19	RLIIM-3018	19
XVIM-18R24	17	RLIM-3616	19	RLDIM-3604	19	RLIIM-3016	19
XVIM-20R24	17	RLIM-3612	19	RLDIM-3024	19	RLIIM-3012	19

INDICE POR No. DE CATALOGO

No. DE CAT.	PAG.	No. DE CAT.	PAG.	No. DE CAT.	PAG.	No. DE CAT.	PAG.
ACCESORIO PERFIL I MEDIANO		CHAROLA PERFIL I PESADO		ACCESORIO PERFIL I PESADO		ACCESORIO PERFIL I PESADO	
RLIIM-3009	19	CHIP-1809	10	VHIP-12R3645	11	VEIP-09R0845	12
RLIIM-3006	19	CHIP-1812	10	VHIP-16R3645	11	VEIP-12R0845	12
RLIIM-3004	19	CHIP-2006	10	VHIP-18R3645	11	VEIP-16R0845	12
RLIIM-2420	19	CHIP-2009	10	VHIP-20R3645	11	VEIP-18R0845	12
RLIIM-2418	19	CHIP-2012	10	VHIP-24R3645	11	VEIP-20R0845	12
RLIIM-2416	19	CHIP-2406	10	VHIP-30R3645	11	VEIP-24R0845	12
RLIIM-2412	19	CHIP-2409	10	VHIP-36R3645	11	VEIP-30R0845	12
RLIIM-2409	19	CHIP-2412	10	VHIP-04R0890	11	VEIP-36R0845	12
RLIIM-2406	19	CHIP-3006	10	VHIP-06R0890	11	VEIP-04R1245	12
RLIIM-2404	19	CHIP-3009	10	VHIP-09R0890	11	VEIP-06R1245	12
RLIIM-2018	19	CHIP-3012	10	VHIP-12R0890	11	VEIP-09R1245	12
RLIIM-2016	19	CHIP-3606	10	VHIP-16R0890	11	VEIP-12R1245	12
RLIIM-2012	19	CHIP-3609	10	VHIP-18R0890	11	VEIP-16R1245	12
RLIIM-2009	19	CHIP-3612	10	VHIP-20R0890	11	VEIP-18R1245	12
RLIIM-2006	19			VHIP-24R0890	11	VEIP-20R1245	12
RLIIM-2004	19	ACCESORIO PERFIL I PESADO		VHIP-30R0890	11	VEIP-24R1245	12
RLIIM-1816	19	VHIP-04R0845	11	VHIP-36R0890	11	VEIP-30R1245	12
RLIIM-1812	19	VHIP-06R0845	11	VHIP-04R1290	11	VEIP-36R1245	12
RLIIM-1809	19	VHIP-09R0845	11	VHIP-06R1290	11	VEIP-04R2445	12
RLIIM-1806	19	VHIP-12R0845	11	VHIP-09R1290	11	VEIP-06R2445	12
RLIIM-1804	19	VHIP-16R0845	11	VHIP-12R1290	11	VEIP-09R2445	12
RLIIM-1612	19	VHIP-18R0845	11	VHIP-16R1290	11	VEIP-12R2445	12
RLIIM-1609	19	VHIP-20R0845	11	VHIP-18R1290	11	VEIP-16R2445	12
RLIIM-1606	19	VHIP-24R0845	11	VHIP-20R1290	11	VEIP-18R2445	12
RLIIM-1604	19	VHIP-30R0845	11	VHIP-24R1290	11	VEIP-20R2445	12
RLIIM-1209	19	VHIP-36R0845	11	VHIP-30R1290	11	VEIP-24R2445	12
RLIIM-1206	19	VHIP-04R1245	11	VHIP-36R1290	11	VEIP-30R2445	12
RLIIM-1204	19	VHIP-06R1245	11	VHIP-04R2490	11	VEIP-36R2445	12
RLIIM-0906	19	VHIP-09R1245	11	VHIP-06R2490	11	VEIP-04R3645	12
RLIIM-0904	19	VHIP-12R1245	11	VHIP-09R2490	11	VEIP-06R3645	12
RLIIM-0604	19	VHIP-16R1245	11	VHIP-12R2490	11	VEIP-09R3645	12
		VHIP-18R1245	11	VHIP-16R2490	11	VEIP-12R3645	12
CHAROLA PERFIL I PESADO		VHIP-20R1245	11	VHIP-18R2490	11	VEIP-16R3645	12
CHIP-0406	10	VHIP-24R1245	11	VHIP-20R2490	11	VEIP-18R3645	12
CHIP-0409	10	VHIP-30R1245	11	VHIP-24R2490	11	VEIP-20R3645	12
CHIP-0412	10	VHIP-36R1245	11	VHIP-30R2490	11	VEIP-24R3645	12
CHIP-0606	10	VHIP-04R2445	11	VHIP-36R2490	11	VEIP-30R3645	12
CHIP-0609	10	VHIP-06R2445	11	VHIP-04R3690	11	VEIP-36R3645	12
CHIP-0612	10	VHIP-09R2445	11	VHIP-06R3690	11	VEIP-04R0890	12
CHIP-0906	10	VHIP-12R2445	11	VHIP-09R3690	11	VEIP-06R0890	12
CHIP-0909	10	VHIP-16R2445	11	VHIP-12R3690	11	VEIP-09R0890	12
CHIP-0912	10	VHIP-18R2445	11	VHIP-16R3690	11	VEIP-12R0890	12
CHIP-1206	10	VHIP-20R2445	11	VHIP-18R3690	11	VEIP-16R0890	12
CHIP-1209	10	VHIP-24R2445	11	VHIP-20R3690	11	VEIP-18R0890	12
CHIP-1212	10	VHIP-30R2445	11	VHIP-24R3690	11	VEIP-20R0890	12
CHIP-1606	10	VHIP-36R2445	11	VHIP-30R3690	11	VEIP-24R0890	12
CHIP-1609	10	VHIP-04R3645	11	VHIP-36R3690	11	VEIP-30R0890	12
CHIP-1612	10	VHIP-06R3645	11	VEIP-04R0845	12	VEIP-36R0890	12
CHIP-1806	10	VHIP-09R3645	11	VEIP-06R0845	12	VEIP-04R1290	12

INDICE POR No. DE CATALOGO

No. DE CAT.	PAG.	No. DE CAT.	PAG.	No. DE CAT.	PAG.	No. DE CAT.	PAG.
ACCESORIO PERFIL I PESADO		ACCESORIO PERFIL I PESADO		ACCESORIO PERFIL I PESADO		ACCESORIO PERFIL I PESADO	
VEIP-06R1290	12	VIIP-04R2445	13	VIIP-36R2490	13	THIP-30R36	14
VEIP-09R1290	12	VIIP-06R2445	13	VIIP-04R3690	13	THIP-36R36	14
VEIP-12R1290	12	VIIP-09R2445	13	VIIP-06R3690	13	XHIP-04R08	15
VEIP-16R1290	12	VIIP-12R2445	13	VIIP-09R3690	13	XHIP-06R08	15
VEIP-18R1290	12	VIIP-16R2445	13	VIIP-12R3690	13	XHIP-09R08	15
VEIP-20R1290	12	VIIP-18R2445	13	VIIP-16R3690	13	XHIP-12R08	15
VEIP-24R1290	12	VIIP-20R2445	13	VIIP-18R3690	13	XHIP-16R08	15
VEIP-30R1290	12	VIIP-24R2445	13	VIIP-20R3690	13	XHIP-18R08	15
VEIP-36R1290	12	VIIP-30R2445	13	VIIP-24R3690	13	XHIP-20R08	15
VEIP-04R2490	12	VIIP-36R2445	13	VIIP-30R3690	13	XHIP-24R08	15
VEIP-06R2490	12	VIIP-04R3645	13	VIIP-36R3690	13	XHIP-30R08	15
VEIP-09R2490	12	VIIP-06R3645	13	THIP-04R08	14	XHIP-36R08	15
VEIP-12R2490	12	VIIP-09R3645	13	THIP-06R08	14	XHIP-04R12	15
VEIP-16R2490	12	VIIP-12R3645	13	THIP-09R08	14	XHIP-06R12	15
VEIP-18R2490	12	VIIP-16R3645	13	THIP-12R08	14	XHIP-09R12	15
VEIP-20R2490	12	VIIP-18R3645	13	THIP-16R08	14	XHIP-12R12	15
VEIP-24R2490	12	VIIP-20R3645	13	THIP-18R08	14	XHIP-16R12	15
VEIP-30R2490	12	VIIP-24R3645	13	THIP-20R08	14	XHIP-18R12	15
VEIP-36R2490	12	VIIP-30R3645	13	THIP-24R08	14	XHIP-20R12	15
VEIP-04R3690	12	VIIP-36R3645	13	THIP-30R08	14	XHIP-24R12	15
VEIP-06R3690	12	VIIP-04R0890	13	THIP-36R08	14	XHIP-30R12	15
VEIP-09R3690	12	VIIP-06R0890	13	THIP-04R12	14	XHIP-36R12	15
VEIP-12R3690	12	VIIP-09R0890	13	THIP-06R12	14	XHIP-04R24	15
VEIP-16R3690	12	VIIP-12R0890	13	THIP-09R12	14	XHIP-06R24	15
VEIP-18R3690	12	VIIP-16R0890	13	THIP-12R12	14	XHIP-09R24	15
VEIP-20R3690	12	VIIP-18R0890	13	THIP-16R12	14	XHIP-12R24	15
VEIP-24R3690	12	VIIP-20R0890	13	THIP-18R12	14	XHIP-16R24	15
VEIP-30R3690	12	VIIP-24R0890	13	THIP-20R12	14	XHIP-18R24	15
VEIP-36R3690	12	VIIP-30R0890	13	THIP-24R12	14	XHIP-20R24	15
VIIP-04R0845	13	VIIP-36R0890	13	THIP-30R12	14	XHIP-24R24	15
VIIP-06R0845	13	VIIP-04R1290	13	THIP-36R12	14	XHIP-30R24	15
VIIP-09R0845	13	VIIP-06R1290	13	THIP-04R24	14	XHIP-36R24	15
VIIP-12R0845	13	VIIP-09R1290	13	THIP-06R24	14	XHIP-04R36	15
VIIP-16R0845	13	VIIP-12R1290	13	THIP-09R24	14	XHIP-06R36	15
VIIP-18R0845	13	VIIP-16R1290	13	THIP-12R24	14	XHIP-09R36	15
VIIP-20R0845	13	VIIP-18R1290	13	THIP-16R24	14	XHIP-12R36	15
VIIP-24R0845	13	VIIP-20R1290	13	THIP-18R24	14	XHIP-16R36	15
VIIP-30R0845	13	VIIP-24R1290	13	THIP-20R24	14	XHIP-18R36	15
VIIP-36R0845	13	VIIP-30R1290	13	THIP-24R24	14	XHIP-20R36	15
VIIP-04R1245	13	VIIP-36R1290	13	THIP-30R24	14	XHIP-24R36	15
VIIP-06R1245	13	VIIP-04R2490	13	THIP-36R24	14	XHIP-30R36	15
VIIP-09R1245	13	VIIP-06R2490	13	THIP-04R36	14	XHIP-36R36	15
VIIP-12R1245	13	VIIP-09R2490	13	THIP-06R36	14	THIP-04R08	16
VIIP-16R1245	13	VIIP-12R2490	13	THIP-09R36	14	TVIP-06R08	16
VIIP-18R1245	13	VIIP-16R2490	13	THIP-12R36	14	TVIP-09R08	16
VIIP-20R1245	13	VIIP-18R2490	13	THIP-16R36	14	TVIP-12R08	16
VIIP-24R1245	13	VIIP-20R2490	13	THIP-18R36	14	TVIP-16R08	16
VIIP-30R1245	13	VIIP-24R2490	13	THIP-20R36	14	TVIP-18R08	16
VIIP-36R1245	13	VIIP-30R2490	13	THIP-24R36	14	TVIP-20R08	16

INDICE POR No. DE CATALOGO

No. DE CAT.	PAG.	No. DE CAT.	PAG.	No. DE CAT.	PAG.	No. DE CAT.	PAG.
ACCESORIO PERFIL I PESADO		ACCESORIO PERFIL I PESADO		ACCESORIO PERFIL I PESADO		ACCESORIO PERFIL I PESADO	
TVIP-24R08	16	XVIP-20R12	17	DYDIP-1845	18	RLIP-0604	19
TVIP-30R08	16	XVIP-24R12	17	DYDIP-2045	18	RLDIP-3630	19
TVIP-36R08	16	XVIP-30R12	17	DYDIP-2445	18	RLDIP-3624	19
TVIP-04R12	16	XVIP-36R12	17	DYDIP-3045	18	RLDIP-3620	19
TVIP-06R12	16	XVIP-04R24	17	DYDIP-3645	18	RLDIP-3618	19
TVIP-09R12	16	XVIP-06R24	17	RLIP-3630	19	RLDIP-3616	19
TVIP-12R12	16	XVIP-09R24	17	RLIP-3624	19	RLDIP-3612	19
TVIP-16R12	16	XVIP-12R24	17	RLIP-3620	19	RLDIP-3609	19
TVIP-18R12	16	XVIP-16R24	17	RLIP-3618	19	RLDIP-3606	19
TVIP-20R12	16	XVIP-18R24	17	RLIP-3616	19	RLDIP-3604	19
TVIP-24R12	16	XVIP-20R24	17	RLIP-3612	19	RLDIP-3024	19
TVIP-30R12	16	XVIP-24R24	17	RLIP-3609	19	RLDIP-3020	19
TVIP-36R12	16	XVIP-30R24	17	RLIP-3606	19	RLDIP-3018	19
TVIP-04R24	16	XVIP-36R24	17	RLIP-3604	19	RLDIP-3016	19
TVIP-06R24	16	XVIP-04R36	17	RLIP-3024	19	RLDIP-3012	19
TVIP-09R24	16	XVIP-06R36	17	RLIP-3020	19	RLDIP-3009	19
TVIP-12R24	16	XVIP-09R36	17	RLIP-3018	19	RLDIP-3006	19
TVIP-16R24	16	XVIP-12R36	17	RLIP-3016	19	RLDIP-3004	19
TVIP-18R24	16	XVIP-16R36	17	RLIP-3012	19	RLDIP-2420	19
TVIP-20R24	16	XVIP-18R36	17	RLIP-3009	19	RLDIP-2418	19
TVIP-24R24	16	XVIP-20R36	17	RLIP-3006	19	RLDIP-2416	19
TVIP-30R24	16	XVIP-24R36	17	RLIP-3004	19	RLDIP-2412	19
TVIP-36R24	16	XVIP-30R36	17	RLIP-2420	19	RLDIP-2409	19
TVIP-04R36	16	XVIP-36R36	17	RLIP-2418	19	RLDIP-2406	19
TVIP-06R36	16	CAIP-04	18	RLIP-2416	19	RLDIP-2404	19
TVIP-09R36	16	CAIP-06	18	RLIP-2412	19	RLDIP-2018	19
TVIP-12R36	16	CAIP-09	18	RLIP-2409	19	RLDIP-2016	19
TVIP-16R36	16	CAIP-12	18	RLIP-2406	19	RLDIP-2012	19
TVIP-18R36	16	CAIP-16	18	RLIP-2404	19	RLDIP-2009	19
TVIP-20R36	16	CAIP-18	18	RLIP-2018	19	RLDIP-2006	19
TVIP-24R36	16	CAIP-20	18	RLIP-2016	19	RLDIP-2004	19
TVIP-30R36	16	CAIP-24	18	RLIP-2012	19	RLDIP-1816	19
TVIP-36R36	16	CAIP-30	18	RLIP-2009	19	RLDIP-1812	19
XVIP-04R08	17	CAIP-36	18	RLIP-2006	19	RLDIP-1809	19
XVIP-06R08	17	DYZIP-0445	18	RLIP-2004	19	RLDIP-1806	19
XVIP-09R08	17	DYZIP-0645	18	RLIP-1816	19	RLDIP-1804	19
XVIP-12R08	17	DYZIP-0945	18	RLIP-1812	19	RLDIP-1612	19
XVIP-16R08	17	DYZIP-1245	18	RLIP-1809	19	RLDIP-1609	19
XVIP-18R08	17	DYZIP-1645	18	RLIP-1806	19	RLDIP-1606	19
XVIP-20R08	17	DYZIP-1845	18	RLIP-1804	19	RLDIP-1604	19
XVIP-24R08	17	DYZIP-2045	18	RLIP-1612	19	RLDIP-1209	19
XVIP-30R08	17	DYZIP-2445	18	RLIP-1609	19	RLDIP-1206	19
XVIP-36R08	17	DYZIP-3045	18	RLIP-1606	19	RLDIP-1204	19
XVIP-04R12	17	DYZIP-3645	18	RLIP-1604	19	RLDIP-0906	19
XVIP-06R12	17	DYDIP-0445	18	RLIP-1209	19	RLDIP-0904	19
XVIP-09R12	17	DYDIP-0645	18	RLIP-1206	19	RLDIP-0604	19
XVIP-12R12	17	DYDIP-0945	18	RLIP-1204	19	RLIIP-3630	19
XVIP-16R12	17	DYDIP-1245	18	RLIP-0906	19	RLIIP-3624	19
XVIP-18R12	17	DYDIP-1645	18	RLIP-0904	19	RLIIP-3620	19

INDICE POR No. DE CATALOGO

No. DE CAT.	PAG.	No. DE CAT.	PAG.	No. DE CAT.	PAG.	No. DE CAT.	PAG.
ACCESORIO PERFIL I PESADO		CHAROLA FONDO SOLIDO LISO		ACCESORIO FONDO SOLIDO LISO		ACCESORIO FONDO SOLIDO LISO	
RLIIP-3618	19	CHZL-18	21	VHZL-12R0890	21	VEZL-09R1245	22
RLIIP-3616	19	CHZL-20	21	VHZL-16R0890	21	VEZL-12R1245	22
RLIIP-3612	19	CHZL-24	21	VHZL-18R0890	21	VEZL-16R1245	22
RLIIP-3609	19	CHZL-30	21	VHZL-20R0890	21	VEZL-18R1245	22
RLIIP-3606	19	CHZL-36	21	VHZL-24R0890	21	VEZL-20R1245	22
RLIIP-3604	19	ACCESORIO FONDO SOLIDO LISO		VHZL-30R0890	21	VEZL-24R1245	22
RLIIP-3024	19	VHZL-04R0845	21	VHZL-36R0890	21	VEZL-30R1245	22
RLIIP-3020	19	VHZL-06R0845	21	VHZL-04R1290	21	VEZL-36R1245	22
RLIIP-3018	19	VHZL-09R0845	21	VHZL-06R1290	21	VEZL-04R2445	22
RLIIP-3016	19	VHZL-12R0845	21	VHZL-09R1290	21	VEZL-06R2445	22
RLIIP-3012	19	VHZL-16R0845	21	VHZL-12R1290	21	VEZL-09R2445	22
RLIIP-3009	19	VHZL-18R0845	21	VHZL-16R1290	21	VEZL-12R2445	22
RLIIP-3006	19	VHZL-20R0845	21	VHZL-18R1290	21	VEZL-16R2445	22
RLIIP-3004	19	VHZL-24R0845	21	VHZL-20R1290	21	VEZL-18R2445	22
RLIIP-2420	19	VHZL-30R0845	21	VHZL-24R1290	21	VEZL-20R2445	22
RLIIP-2418	19	VHZL-36R0845	21	VHZL-30R1290	21	VEZL-24R2445	22
RLIIP-2416	19	VHZL-04R1245	21	VHZL-36R1290	21	VEZL-30R2445	22
RLIIP-2412	19	VHZL-06R1245	21	VHZL-04R2490	21	VEZL-36R2445	22
RLIIP-2409	19	VHZL-09R1245	21	VHZL-06R2490	21	VEZL-04R3645	22
RLIIP-2406	19	VHZL-12R1245	21	VHZL-09R2490	21	VEZL-06R3645	22
RLIIP-2404	19	VHZL-16R1245	21	VHZL-12R2490	21	VEZL-09R3645	22
RLIIP-2018	19	VHZL-18R1245	21	VHZL-16R2490	21	VEZL-12R3645	22
RLIIP-2016	19	VHZL-20R1245	21	VHZL-18R2490	21	VEZL-16R3645	22
RLIIP-2012	19	VHZL-24R1245	21	VHZL-20R2490	21	VEZL-18R3645	22
RLIIP-2009	19	VHZL-30R1245	21	VHZL-24R2490	21	VEZL-20R3645	22
RLIIP-2006	19	VHZL-36R1245	21	VHZL-30R2490	21	VEZL-24R3645	22
RLIIP-2004	19	VHZL-04R2445	21	VHZL-36R2490	21	VEZL-30R3645	22
RLIIP-1816	19	VHZL-06R2445	21	VHZL-04R3690	21	VEZL-36R3645	22
RLIIP-1812	19	VHZL-09R2445	21	VHZL-06R3690	21	VEZL-04R0890	22
RLIIP-1809	19	VHZL-12R2445	21	VHZL-09R3690	21	VEZL-06R0890	22
RLIIP-1806	19	VHZL-16R2445	21	VHZL-12R3690	21	VEZL-09R0890	22
RLIIP-1804	19	VHZL-18R2445	21	VHZL-16R3690	21	VEZL-12R0890	22
RLIIP-1612	19	VHZL-20R2445	21	VHZL-18R3690	21	VEZL-16R0890	22
RLIIP-1609	19	VHZL-24R2445	21	VHZL-20R3690	21	VEZL-18R0890	22
RLIIP-1606	19	VHZL-30R2445	21	VHZL-24R3690	21	VEZL-20R0890	22
RLIIP-1604	19	VHZL-36R2445	21	VHZL-30R3690	21	VEZL-24R0890	22
RLIIP-1209	19	VHZL-04R3645	21	VHZL-36R3690	21	VEZL-30R0890	22
RLIIP-1206	19	VHZL-06R3645	21	VEZL-04R0845	22	VEZL-36R0890	22
RLIIP-1204	19	VHZL-09R3645	21	VEZL-06R0845	22	VEZL-04R1290	22
RLIIP-0906	19	VHZL-12R3645	21	VEZL-09R0845	22	VEZL-06R1290	22
RLIIP-0904	19	VHZL-16R3645	21	VEZL-12R0845	22	VEZL-09R1290	22
RLIIP-0604	19	VHZL-18R3645	21	VEZL-16R0845	22	VEZL-12R1290	22
		VHZL-20R3645	21	VEZL-18R0845	22	VEZL-16R1290	22
CHAROLA FONDO SOLIDO LISO		VHZL-24R3645	21	VEZL-20R0845	22	VEZL-08R1290	22
CHZL-04	21	VHZL-30R3645	21	VEZL-24R0845	22	VEZL-20R1290	22
CHZL-06	21	VHZL-36R3645	21	VEZL-30R0845	22	VEZL-24R1290	22
CHZL-09	21	VHZL-04R0890	21	VEZL-36R0845	22	VEZL-30R1290	22
CHZL-12	21	VHZL-06R0890	21	VEZL-04R1245	22	VEZL-36R1290	22
CHZL-16	21	VHZL-09R0890	21	VEZL-06R1245	22	VEZL-04R2490	22

INDICE POR No. DE CATALOGO

No. DE CAT.	PAG.	No. DE CAT.	PAG.	No. DE CAT.	PAG.	No. DE CAT.	PAG.
ACCESORIO FONDO SOLIDO LISO		ACCESORIO FONDO SOLIDO LISO		ACCESORIO FONDO SOLIDO LISO		ACCESORIO FONDO SOLIDO LISO	
VEZL-06R2490	22	VIZL-04R3645	23	VIZL-36R3690	23	XHZL-30R08	25
VEZL-09R2490	22	VIZL-06R3645	23	THZL-04R08	24	XHZL-36R08	25
VEZL-12R2490	22	VIZL-09R3645	23	THZL-06R08	24	XHZL-04R12	25
VEZL-16R2490	22	VIZL-12R3645	23	THZL-09R08	24	XHZL-06R12	25
VEZL-18R2490	22	VIZL-16R3645	23	THZL-12R08	24	XHZL-09R12	25
VEZL-20R2490	22	VIZL-18R3645	23	THZL-16R08	24	XHZL-12R12	25
VEZL-24R2490	22	VIZL-20R3645	23	THZL-18R08	24	XHZL-16R12	25
VEZL-30R2490	22	VIZL-24R3645	23	THZL-20R08	24	XHZL-18R12	25
VEZL-36R2490	22	VIZL-30R3645	23	THZL-24R08	24	XHZL-20R12	25
VEZL-04R3690	22	VIZL-36R3645	23	THZL-30R08	24	XHZL-24R12	25
VEZL-06R3690	22	VIZL-04R0890	23	THZL-36R08	24	XHZL-30R12	25
VEZL-09R3690	22	VIZL-06R0890	23	THZL-04R12	24	XHZL-36R12	25
VEZL-12R3690	22	VIZL-09R0890	23	THZL-06R12	24	XHZL-04R24	25
VEZL-16R3690	22	VIZL-12R0890	23	THZL-09R12	24	XHZL-06R24	25
VEZL-18R3690	22	VIZL-16R0890	23	THZL-12R12	24	XHZL-09R24	25
VEZL-20R3690	22	VIZL-18R0890	23	THZL-16R12	24	XHZL-12R24	25
VEZL-24R3690	22	VIZL-20R0890	23	THZL-18R12	24	XHZL-16R24	25
VEZL-30R3690	22	VIZL-24R0890	23	THZL-20R12	24	XHZL-18R24	25
VEZL-36R3690	22	VIZL-30R0890	23	THZL-24R12	24	XHZL-20R24	25
VIZL-04R0845	23	VIZL-36R0890	23	THZL-30R12	24	XHZL-24R24	25
VIZL-06R0845	23	VIZL-04R1290	23	THZL-36R12	24	XHZL-30R24	25
VIZL-09R0845	23	VIZL-06R1290	23	THZL-04R24	24	XHZL-36R24	25
VIZL-12R0845	23	VIZL-09R1290	23	THZL-06R24	24	XHZL-04R36	25
VIZL-16R0845	23	VIZL-12R1290	23	THZL-09R24	24	XHZL-06R36	25
VIZL-18R0845	23	VIZL-16R1290	23	THZL-12R24	24	XHZL-09R36	25
VIZL-20R0845	23	VIZL-18R1290	23	THZL-16R24	24	XHZL-12R36	25
VIZL-24R0845	23	VIZL-20R1290	23	THZL-18R24	24	XHZL-16R36	25
VIZL-30R0845	23	VIZL-24R1290	23	THZL-20R24	24	XHZL-18R36	25
VIZL-36R0845	23	VIZL-30R1290	23	THZL-24R24	24	XHZL-20R36	25
VIZL-04R1245	23	VIZL-36R1290	23	THZL-30R24	24	XHZL-24R36	25
VIZL-06R1245	23	VIZL-04R2490	23	THZL-36R24	24	XHZL-30R36	25
VIZL-09R1245	23	VIZL-06R2490	23	THZL-04R36	24	XHZL-36R36	25
VIZL-12R1245	23	VIZL-09R2490	23	THZL-06R36	24	TVZL-04R08	26
VIZL-16R1245	23	VIZL-12R2490	23	THZL-09R36	24	TVZL-06R08	26
VIZL-18R1245	23	VIZL-16R2490	23	THZL-12R36	24	TVZL-09R08	26
VIZL-20R1245	23	VIZL-18R2490	23	THZL-16R36	24	TVZL-12R08	26
VIZL-24R1245	23	VIZL-20R2490	23	THZL-18R36	24	TVZL-16R08	26
VIZL-30R1245	23	VIZL-24R2490	23	THZL-20R36	24	TVZL-18R08	26
VIZL-36R1245	23	VIZL-30R2490	23	THZL-24R36	24	TVZL-20R08	26
VIZL-04R2445	23	VIZL-36R2490	23	THZL-30R36	24	TVZL-24R08	26
VIZL-06R2445	23	VIZL-04R3690	23	THZL-36R36	24	TVZL-30R08	26
VIZL-09R2445	23	VIZL-06R3690	23	XHZL-04R08	25	TVZL-36R08	26
VIZL-12R2445	23	VIZL-09R3690	23	XHZL-06R08	25	TVZL-04R12	26
VIZL-16R2445	23	VIZL-12R3690	23	XHZL-09R08	25	TVZL-06R12	26
VIZL-18R2445	23	VIZL-16R3690	23	XHZL-12R08	25	TVZL-09R12	26
VIZL-20R2445	23	VIZL-18R3690	23	XHZL-16R08	25	TVZL-12R12	26
VIZL-24R2445	23	VIZL-20R3690	23	XHZL-18R08	25	TVZL-16R12	26
VIZL-30R2445	23	VIZL-24R3690	23	XHZL-20R08	25	TVZL-18R12	26
VIZL-36R2445	23	VIZL-30R3690	23	XHZL-24R08	25	TVZL-20R12	26

PRODUCTOS SOPORTES ELECTRICOS

INDICE POR No. DE CATALOGO

No. DE CAT.	PAG.	No. DE CAT.	PAG.	No. DE CAT.	PAG.	No. DE CAT.	PAG.
ACCESORIO FONDO SOLIDO LISO		ACCESORIO FONDO SOLIDO LISO		ACCESORIO FONDO SOLIDO LISO		ACCESORIO FONDO SOLIDO LISO	
TVZL-24R12	26	DYDZL-20	27	RLDZL-3630	28	RLIZL-3616	28
TVZL-30R12	26	DYDZL-24	27	RLDZL-3624	28	RLIZL-3612	28
TVZL-36R12	26	DYDZL-30	27	RLDZL-3620	28	RLIZL-3609	28
TVZL-04R24	26	DYDZL-36	27	RLDZL-3618	28	RLIZL-3606	28
TVZL-06R24	26	RLZL-3630	28	RLDZL-3616	28	RLIZL-3604	28
TVZL-09R24	26	RLZL-3624	28	RLDZL-3612	28	RLIZL-3024	28
TVZL-12R24	26	RLZL-3620	28	RLDZL-3609	28	RLIZL-3020	28
TVZL-16R24	26	RLZL-3618	28	RLDZL-3606	28	RLIZL-3018	28
TVZL-18R24	26	RLZL-3616	28	RLDZL-3604	28	RLIZL-3016	28
TVZL-20R24	26	RLZL-3612	28	RLDZL-3024	28	RLIZL-3012	28
TVZL-24R24	26	RLZL-3609	28	RLDZL-3020	28	RLIZL-3009	28
TVZL-30R24	26	RLZL-3606	28	RLDZL-3018	28	RLIZL-3006	28
TVZL-36R24	26	RLZL-3604	28	RLDZL-3016	28	RLIZL-3004	28
TVZL-04R36	26	RLZL-3024	28	RLDZL-3012	28	RLIZL-2420	28
TVZL-06R36	26	RLZL-3020	28	RLDZL-3009	28	RLIZL-2418	28
TVZL-09R36	26	RLZL-3018	28	RLDZL-3006	28	RLIZL-2416	28
TVZL-12R36	26	RLZL-3016	28	RLDZL-3004	28	RLIZL-2412	28
TVZL-16R36	26	RLZL-3012	28	RLDZL-2420	28	RLIZL-2409	28
TVZL-18R36	26	RLZL-3009	28	RLDZL-2418	28	RLIZL-2406	28
TVZL-20R36	26	RLZL-3006	28	RLDZL-2416	28	RLIZL-2404	28
TVZL-24R36	26	RLZL-3004	28	RLDZL-2412	28	RLIZL-2018	28
TVZL-30R36	26	RLZL-2420	28	RLDZL-2409	28	RLIZL-2016	28
TVZL-36R36	26	RLZL-2418	28	RLDZL-2406	28	RLIZL-2012	28
CAZL-04	27	RLZL-2416	28	RLDZL-2404	28	RLIZL-2009	28
CAZL-06	27	RLZL-2412	28	RLDZL-2018	28	RLIZL-2006	28
CAZL-09	27	RLZL-2409	28	RLDZL-2016	28	RLIZL-2004	28
CAZL-12	27	RLZL-2406	28	RLDZL-2012	28	RLIZL-1816	28
CAZL-16	27	RLZL-2404	28	RLDZL-2009	28	RLIZL-1812	28
CAZL-18	27	RLZL-2018	28	RLDZL-2006	28	RLIZL-1809	28
CAZL-20	27	RLZL-2016	28	RLDZL-2004	28	RLIZL-1806	28
CAZL-24	27	RLZL-2012	28	RLDZL-1816	28	RLIZL-1804	28
CAZL-30	27	RLZL-2009	28	RLDZL-1812	28	RLIZL-1612	28
CAZL-36	27	RLZL-2006	28	RLDZL-1809	28	RLIZL-1609	28
DYZZL-04	27	RLZL-2004	28	RLDZL-1806	28	RLIZL-1606	28
DYZZL-06	27	RLZL-1816	28	RLDZL-1804	28	RLIZL-1604	28
DYZZL-09	27	RLZL-1812	28	RLDZL-1612	28	RLIZL-1209	28
DYZZL-12	27	RLZL-1809	28	RLDZL-1609	28	RLIZL-1206	28
DYZZL-16	27	RLZL-1806	28	RLDZL-1606	28	RLIZL-1204	28
DYZZL-18	27	RLZL-1804	28	RLDZL-1604	28	RLIZL-0906	28
DYZZL-20	27	RLZL-1612	28	RLDZL-1209	28	RLIZL-0904	28
DYZZL-24	27	RLZL-1609	28	RLDZL-1206	28	RLIZL-0604	28
DYZZL-30	27	RLZL-1606	28	RLDZL-1204	28		
DYZZL-36	27	RLZL-1604	28	RLDZL-0906	28		
DYDZL-04	27	RLZL-1209	28	RLDZL-0904	28	CHAROLA FONDO SOLIDO PERF.	
DYDZL-06	27	RLZL-1206	28	RLDZL-0604	28	CHZP-04	21
DYDZL-09	27	RLZL-1204	28	RLIZL-3630	28	CHZP-06	21
DYDZL-12	27	RLZL-0906	28	RLIZL-3624	28	CHZP-09	21
DYDZL-16	27	RLZL-0904	28	RLIZL-3620	28	CHZP-12	21
DYDZL-18	27	RLZL-0604	28	RLIZL-3618	28	CHZP-16	21
						CHZP-18	21

INDICE POR No. DE CATALOGO

No. DE CAT.	PAG.	No. DE CAT.	PAG.	No. DE CAT.	PAG.	No. DE CAT.	PAG.
CHAROLA FONDO SOLIDO PERF.		ACCESORIO FONDO SOLIDO PERF.		ACCESORIO FONDO SOLIDO PERF.		ACCESORIO FONDO SOLIDO PERF.	
CHZP-20	21	VHZP-12R0890	21	VEZP-09R1245	22	VEZP-06R2490	22
CHZP-24	21	VHZP-16R0890	21	VEZP-12R1245	22	VEZP-09R2490	22
CHZP-30	21	VHZP-18R0890	21	VEZP-16R1245	22	VEZP-12R2490	22
CHZP-36	21	VHZP-20R0890	21	VEZP-18R1245	22	VEZP-16R2490	22
ACCESORIO FONDO SOLIDO PERF.		VHZP-24R0890	21	VEZP-20R1245	22	VEZP-18R2490	22
VHZP-04R0845	21	VHZP-30R0890	21	VEZP-24R1245	22	VEZP-20R2490	22
VHZP-06R0845	21	VHZP-36R0890	21	VEZP-30R1245	22	VEZP-24R2490	22
VHZP-09R0845	21	VHZP-04R1290	21	VEZP-36R1245	22	VEZP-30R2490	22
VHZP-12R0845	21	VHZP-06R1290	21	VEZP-04R2445	22	VEZP-36R2490	22
VHZP-16R0845	21	VHZP-09R1290	21	VEZP-06R2445	22	VEZP-04R3690	22
VHZP-18R0845	21	VHZP-12R1290	21	VEZP-09R2445	22	VEZP-06R3690	22
VHZP-20R0845	21	VHZP-16R1290	21	VEZP-12R2445	22	VEZP-09R3690	22
VHZP-24R0845	21	VHZP-18R1290	21	VEZP-16R2445	22	VEZP-12R3690	22
VHZP-30R0845	21	VHZP-20R1290	21	VEZP-18R2445	22	VEZP-16R3690	22
VHZP-36R0845	21	VHZP-24R1290	21	VEZP-20R2445	22	VEZP-18R3690	22
VHZP-04R1245	21	VHZP-30R1290	21	VEZP-24R2445	22	VEZP-20R3690	22
VHZP-06R1245	21	VHZP-36R1290	21	VEZP-30R2445	22	VEZP-24R3690	22
VHZP-09R1245	21	VHZP-04R2490	21	VEZP-36R2445	22	VEZP-30R3690	22
VHZP-12R1245	21	VHZP-06R2490	21	VEZP-04R3645	22	VEZP-36R3690	22
VHZP-16R1245	21	VHZP-09R2490	21	VEZP-06R3645	22	VIZP-04R0845	23
VHZP-18R1245	21	VHZP-12R2490	21	VEZP-09R3645	22	VIZP-06R0845	23
VHZP-20R1245	21	VHZP-16R2490	21	VEZP-12R3645	22	VIZP-09R0845	23
VHZP-24R1245	21	VHZP-18R2490	21	VEZP-16R3645	22	VIZP-12R0845	23
VHZP-30R1245	21	VHZP-20R2490	21	VEZP-18R3645	22	VIZP-16R0845	23
VHZP-36R1245	21	VHZP-24R2490	21	VEZP-20R3645	22	VIZP-18R0845	23
VHZP-04R2445	21	VHZP-30R2490	21	VEZP-24R3645	22	VIZP-20R0845	23
VHZP-06R2445	21	VHZP-36R2490	21	VEZP-30R3645	22	VIZP-24R0845	23
VHZP-09R2445	21	VHZP-04R3690	21	VEZP-36R3645	22	VIZP-30R0845	23
VHZP-12R2445	21	VHZP-06R3690	21	VEZP-04R0890	22	VIZP-36R0845	23
VHZP-16R2445	21	VHZP-09R3690	21	VEZP-06R0890	22	VIZP-04R1245	23
VHZP-18R2445	21	VHZP-12R3690	21	VEZP-09R0890	22	VIZP-06R1245	23
VHZP-20R2445	21	VHZP-16R3690	21	VEZP-12R0890	22	VIZP-09R1245	23
VHZP-24R2445	21	VHZP-18R3690	21	VEZP-16R0890	22	VIZP-12R1245	23
VHZP-30R2445	21	VHZP-20R3690	21	VEZP-18R0890	22	VIZP-16R1245	23
VHZP-36R2445	21	VHZP-24R3690	21	VEZP-20R0890	22	VIZP-18R1245	23
VHZP-04R3645	21	VHZP-30R3690	21	VEZP-24R0890	22	VIZP-20R1245	23
VHZP-06R3645	21	VHZP-36R3690	21	VEZP-30R0890	22	VIZP-24R1245	23
VHZP-09R3645	21	VEZP-04R0845	22	VEZP-36R0890	22	VIZP-30R1245	23
VHZP-12R3645	21	VEZP-06R0845	22	VEZP-04R1290	22	VIZP-36R1245	23
VHZP-16R3645	21	VEZP-09R0845	22	VEZP-06R1290	22	VIZP-04R2445	23
VHZP-18R3645	21	VEZP-12R0845	22	VEZP-09R1290	22	VIZP-06R2445	23
VHZP-20R3645	21	VEZP-16R0845	22	VEZP-12R1290	22	VIZP-09R2445	23
VHZP-24R3645	21	VEZP-18R0845	22	VEZP-16R1290	22	VIZP-12R2445	23
VHZP-30R3645	21	VEZP-20R0845	22	VEZP-18R1290	22	VIZP-16R2445	23
VHZP-36R3645	21	VEZP-24R0845	22	VEZP-20R1290	22	VIZP-18R2445	23
VHZP-04R0890	21	VEZP-30R0845	22	VEZP-24R1290	22	VIZP-20R2445	23
VHZP-06R0890	21	VEZP-36R0845	22	VEZP-30R1290	22	VIZP-24R2445	23
VHZP-09R0890	21	VEZP-04R1245	22	VEZP-36R1290	22	VIZP-30R2445	23
		VEZP-06R1245	22	VEZP-04R2490	22	VIZP-36R2445	23

PRODUCTOS SOPORTES ELECTRICOS

INDICE POR No. DE CATALOGO

No. DE CAT.	PAG.	No. DE CAT.	PAG.	No. DE CAT.	PAG.	No. DE CAT.	PAG.
ACCESORIO FONDO SOLIDO PERF.		ACCESORIO F. S. P.		ACCESORIO F. S. P.		ACCESORIO F. S. P.	
VIZP-04R3645	23	VIZP-36R3690	23	XHZP-30R08	25	TVZP-24R12	26
VIZP-06R3645	23	THZP-04R08	24	XHZP-36R08	25	TVZP-30R12	26
VIZP-09R3645	23	THZP-06R08	24	XHZP-04R12	25	TVZP-36R12	26
VIZP-12R3645	23	THZP-09R08	24	XHZP-06R12	25	TVZP-04R24	26
VIZP-16R3645	23	THZP-12R08	24	XHZP-09R12	25	TVZP-06R24	26
VIZP-18R3645	23	THZP-16R08	24	XHZP-12R12	25	TVZP-09R24	26
VIZP-20R3645	23	THZP-18R08	24	XHZP-16R12	25	TVZP-12R24	26
VIZP-24R3645	23	THZP-20R08	24	XHZP-18R12	25	TVZP-16R24	26
VIZP-30R3645	23	THZP-24R08	24	XHZP-20R12	25	TVZP-18R24	26
VIZP-36R3645	23	THZP-30R08	24	XHZP-24R12	25	TVZP-20R24	26
VIZP-04R0890	23	THZP-36R08	24	XHZP-30R12	25	TVZP-24R24	26
VIZP-06R0890	23	THZP-04R12	24	XHZP-36R12	25	TVZP-30R24	26
VIZP-09R0890	23	THZP-06R12	24	XHZP-04R24	25	TVZP-36R24	26
VIZP-12R0890	23	THZP-09R12	24	XHZP-06R24	25	TVZP-04R36	26
VIZP-16R0890	23	THZP-12R12	24	XHZP-09R24	25	TVZP-06R36	26
VIZP-18R0890	23	THZP-16R12	24	XHZP-12R24	25	TVZP-09R36	26
VIZP-20R0890	23	THZP-18R12	24	XHZP-16R24	25	TVZP-12R36	26
VIZP-24R0890	23	THZP-20R12	24	XHZP-18R24	25	TVZP-16R36	26
VIZP-30R0890	23	THZP-24R12	24	XHZP-20R24	25	TVZP-18R36	26
VIZP-36R0890	23	THZP-30R12	24	XHZP-24R24	25	TVZP-20R36	26
VIZP-04R1290	23	THZP-36R12	24	XHZP-30R24	25	TVZP-24R36	26
VIZP-06R1290	23	THZP-04R24	24	XHZP-36R24	25	TVZP-30R36	26
VIZP-09R1290	23	THZP-06R24	24	XHZP-04R36	25	TVZP-36R36	26
VIZP-12R1290	23	THZP-09R24	24	XHZP-06R36	25	CAZP-04	27
VIZP-16R1290	23	THZP-12R24	24	XHZP-09R36	25	CAZP-06	27
VIZP-18R1290	23	THZP-16R24	24	XHZP-12R36	25	CAZP-09	27
VIZP-20R1290	23	THZP-18R24	24	XHZP-16R36	25	CAZP-12	27
VIZP-24R1290	23	THZP-20R24	24	XHZP-18R36	25	CAZP-16	27
VIZP-30R1290	23	THZP-24R24	24	XHZP-20R36	25	CAZP-18	27
VIZP-36R1290	23	THZP-30R24	24	XHZP-24R36	25	CAZP-20	27
VIZP-04R2490	23	THZP-36R24	24	XHZP-30R36	25	CAZP-24	27
VIZP-06R2490	23	THZP-04R36	24	XHZP-36R36	25	CAZP-30	27
VIZP-09R2490	23	THZP-06R36	24	TVZP-04R08	26	CAZP-36	27
VIZP-12R2490	23	THZP-09R36	24	TVZP-06R08	26	DYZP-4	27
VIZP-16R2490	23	THZP-12R36	24	TVZP-09R08	26	DYZP-6	27
VIZP-18R2490	23	THZP-16R36	24	TVZP-12R08	26	DYZP-9	27
VIZP-20R2490	23	THZP-18R36	24	TVZP-16R08	26	DYZP-12	27
VIZP-24R2490	23	THZP-20R36	24	TVZP-18R08	26	DYZP-16	27
VIZP-30R2490	23	THZP-24R36	24	TVZP-20R08	26	DYZP-18	27
VIZP-36R2490	23	THZP-30R36	24	TVZP-24R08	26	DYZP-20	27
VIZP-04R3690	23	THZP-36R36	24	TVZP-30R08	26	DYZP-24	27
VIZP-06R3690	23	XHZP-04R08	25	TVZP-36R08	26	DYZP-30	27
VIZP-09R3690	23	XHZP-06R08	25	TVZP-04R12	26	DYZP-36	27
VIZP-12R3690	23	XHZP-09R08	25	TVZP-06R12	26	DYDZP-4	27
VIZP-16R3690	23	XHZP-12R08	25	TVZP-09R12	26	DYDZP-6	27
VIZP-18R3690	23	XHZP-16R08	25	TVZP-12R12	26	DYDZP-9	27
VIZP-20R3690	23	XHZP-18R08	25	TVZP-16R12	26	DYDZP-12	27
VIZP-24R3690	23	XHZP-20R08	25	TVZP-18R12	26	DYDZP-16	27
VIZP-30R3690	23	XHZP-24R08	25	TVZP-20R12	26	DYDZP-18	27

INDICE POR No. DE CATALOGO

No. DE CAT.	PAG.	No. DE CAT.	PAG.	No. DE CAT.	PAG.	No. DE CAT.	PAG.
ACCESORIO FONDO SOLIDO PERF.		ACCESORIO FONDO SOLIDO PERF.		ACCESORIO FONDO SOLIDO PERF.		ACCESORIOS DE ENSAMBLE	
DYDZP-20	27	RLDZP-3630	28	RLIZP-3616	28	ARR-1	30
DYDZP-24	27	RLDZP-3624	28	RLIZP-3612	28	ARR-2	30
DYDZP-30	27	RLDZP-3620	28	RLIZP-3609	28	ARR-3	30
DYDZP-36	27	RLDZP-3618	28	RLIZP-3606	28	ARR-4	30
RLZP-3630	28	RLDZP-3616	28	RLIZP-3604	28	ARR-5	30
RLZP-3624	28	RLDZP-3612	28	RLIZP-3024	28	ARR-6	30
RLZP-3620	28	RLDZP-3609	28	RLIZP-3020	28	ARR-7	30
RLZP-3618	28	RLDZP-3606	28	RLIZP-3018	28	ARR-8	30
RLZP-3616	28	RLDZP-3604	28	RLIZP-3016	28	PTR-04	31
RLZP-3612	28	RLDZP-3024	28	RLIZP-3012	28	PTR-06	31
RLZP-3609	28	RLDZP-3020	28	RLIZP-3009	28	PTR-09	31
RLZP-3606	28	RLDZP-3018	28	RLIZP-3006	28	PTR-12	31
RLZP-3604	28	RLDZP-3016	28	RLIZP-3004	28	PTR-16	31
RLZP-3024	28	RLDZP-3012	28	RLIZP-2420	28	PTR-18	31
RLZP-3020	28	RLDZP-3009	28	RLIZP-2418	28	PTR-20	31
RLZP-3018	28	RLDZP-3006	28	RLIZP-2416	28	PTR-24	31
RLZP-3016	28	RLDZP-3004	28	RLIZP-2412	28	PTR-30	31
RLZP-3012	28	RLDZP-2420	28	RLIZP-2409	28	PTR-36	31
RLZP-3009	28	RLDZP-2418	28	RLIZP-2406	28	ACC-04	31
RLZP-3006	28	RLDZP-2416	28	RLIZP-2404	28	ACC-06	31
RLZP-3004	28	RLDZP-2412	28	RLIZP-2018	28	ACC-09	31
RLZP-2420	28	RLDZP-2409	28	RLIZP-2016	28	ACC-12	31
RLZP-2418	28	RLDZP-2406	28	RLIZP-2012	28	ACC-16	31
RLZP-2416	28	RLDZP-2404	28	RLIZP-2009	28	ACC-18	31
RLZP-2412	28	RLDZP-2018	28	RLIZP-2006	28	ACC-20	31
RLZP-2409	28	RLDZP-2016	28	RLIZP-2004	28	ACC-24	31
RLZP-2406	28	RLDZP-2012	28	RLIZP-1816	28	ACC-30	31
RLZP-2404	28	RLDZP-2009	28	RLIZP-1812	28	ACC-36	31
RLZP-2018	28	RLDZP-2006	28	RLIZP-1809	28	BC-04R02A	31
RLZP-2016	28	RLDZP-2004	28	RLIZP-1806	28	BC-06R02A	31
RLZP-2012	28	RLDZP-1816	28	RLIZP-1804	28	BC-09R02A	31
RLZP-2009	28	RLDZP-1812	28	RLIZP-1612	28	BC-12R02A	31
RLZP-2006	28	RLDZP-1809	28	RLIZP-1609	28	BC-16R02A	31
RLZP-2004	28	RLDZP-1806	28	RLIZP-1606	28	BC-18R02A	31
RLZP-1816	28	RLDZP-1804	28	RLIZP-1604	28	BC-20R02A	31
RLZP-1812	28	RLDZP-1612	28	RLIZP-1209	28	BC-24R02A	31
RLZP-1809	28	RLDZP-1609	28	RLIZP-1206	28	BC-30R02A	31
RLZP-1806	28	RLDZP-1606	28	RLIZP-1204	28	BC-36R02A	31
RLZP-1804	28	RLDZP-1604	28	RLIZP-0906	28	BC-04R05A	31
RLZP-1612	28	RLDZP-1209	28	RLIZP-0904	28	BC-06R05A	31
RLZP-1609	28	RLDZP-1206	28	RLIZP-0604	28	BC-09R05A	31
RLZP-1606	28	RLDZP-1204	28			BC-12R05A	31
RLZP-1604	28	RLDZP-0906	28			BC-16R05A	31
RLZP-1209	28	RLDZP-0904	28	ACCESORIOS DE ENSAMBLE		BC-18R05A	31
RLZP-1206	28	RLDZP-0604	28	AZ-4.5	29	BC-20R05A	31
RLZP-1204	28	RLIZP-3630	28	AR-4.5	29	BC-24R05A	31
RLZP-0906	28	RLIZP-3624	28	AL-4.5	29	BC-30R05A	31
RLZP-0904	28	RLIZP-3620	28	AEZ	29	BC-36R05A	31
RLZP-0604	28	RLIZP-3618	28	EA	30	BC-36R05A	31
				AH	30	BSCH	32

INDICE POR No. DE CATALOGO

No. DE CAT.	PAG.	No. DE CAT.	PAG.	No. DE CAT.	PAG.	No. DE CAT.	PAG.
ACCESORIOS DE ENSAMBLE		TAPAS PARA TRAMO RECTO		ACCESORIOS DE MONTAJE		SSH-38	
B5H-48	32	TACH-20	33	MPPI-09	34	SSH-12	37
B5H-72	32	TACH-24	33	MPPI-12	34	SSH-58	37
BSVE-R0845	32	TACH-30	33	MPPI-16	34	SDH-38	37
BSVE-R1245	32	TACH-36	33	MPPI-18	34	SDH-12	37
BSVE-R2445	32	TSSCH-04	33	MPPI-20	34	SDH-58	37
BSVE-R3645	32	TSSCH-06	33	MPPI-24	34	SV-1	37
BSVE-R0890	32	TSSCH-09	33	MPPI-30	34	SV-2	37
BSVE-R1290	32	TSSCH-12	33	MPPI-36	34	SV-3	37
BSVE-R2490	32	TSSCH-16	33	MC-04	35	SV-5	37
BSVE-R3690	32	TSSCH-18	33	MC-06	35	SV-6	37
BSVI-R0845	32	TSSCH-20	33	MC-09	35	SP-1	37
BSVI-R1245	32	TSSCH-24	33	MC-12	35	SP-2	37
BSVI-R2445	32	TSSCH-30	33	MC-16	35	SP-3	37
BSVI-R3645	32	TSSCH-36	33	MC-18	35	SP-5	37
BSVI-R0890	32	TRVCH-04	33	MC-20	35	SP-6	37
BSVI-R1290	32	TRVCH-06	33	MC-24	35	CLAMP-112	38
BSVI-R2490	32	TRVCH-09	33	MC-30	35	CACF-234	38
BSVI-R3690	32	TRVCH-12	33	MC-36	35	CAFL-334	38
CC-99NI	32	TRVCH-16	33	CVPP-120	35	CAFA-434	38
CC-9940	32	TRVCH-18	33	CVP-120	35	CVR-38	38
CC-991620	32	TRVCH-20	33			CVR-12	38
		TRVCH-24	33	ACCESORIOS DE MONTAJE		CVR-58	38
		TRVCH-30	33	CPPV-04	36	CVR-14	38
TAPAS PARA TRAMO RECTO		TRVCH-36	33	CPPV-06	36	CHAROLA TIPO MARINO	
TRCH-04	33	TRVCH-04	33	CPPV-12	36	CHM-10035	39
TRCH-06	33	TRVCH-06	33	CPPV-16	36	CHM-20035	39
TRCH-09	33	TRVCH-09	33	CPPV-18	36	CHM-30035	39
TRCH-12	33	TRVCH-12	33	CPPV-20	36	CHM-40035	39
TRCH-16	33	TRVCH-16	33	CPPV-24	36	CHM-50035	39
TRCH-18	33	TRVCH-18	33	CPPV-30	36	CHM-60035	39
TRCH-20	33	TRVCH-20	33	CPPV-36	36	CHM-10060	39
TRCH-24	33	TRVCH-24	33	CPV-04	36	CHM-20060	39
TRCH-30	33	TRVCH-30	33	CPV-06	36	CHM-30060	39
TRCH-36	33	TRVCH-36	33	CPV-09	36	CHM-40060	39
TRCCH-04	33	CST-14	33	CPV-12	36	CHM-50060	39
TRCCH-06	33			CPV-16	36	CHM-60060	39
TRCCH-09	33	ACCESORIOS DE MONTAJE		CPV-18	36	CHM-10085	39
TRCCH-12	33	MPP-04	34	CPV-20	36	CHM-20085	39
TRCCH-16	33	MPP-06	34	CPV-24	36	CHM-30085	39
TRCCH-18	33	MPP-09	34	CPV-30	36	CHM-40085	39
TRCCH-20	33	MPP-12	34	CPV-36	36	CHM-50085	39
TRCCH-24	33	MPP-16	34	CU-38	36	CHM-60085	39
TRCCH-30	33	MPP-18	34	CU-12	36	CHM-100110	39
TRCCH-36	33	MPP-20	34	CU-58	36	CHM-200110	39
TACH-04	33	MPP-24	34	VR-14300	36	CHM-300110	39
TACH-06	33	MPP-30	34	VR-38300	36	CHM-400110	39
TACH-09	33	MPP-36	34	VR-12300	36	CHM-500110	39
TACH-12	33	MPPI-04	34	VR-58300	36	CHM-600110	39
TACH-16	33	MPPI-06	34				
TACH-18	33						

INDICE POR No. DE CATALOGO

No. DE CAT.	PAG.	No. DE CAT.	PAG.	No. DE CAT.	PAG.	No. DE CAT.	PAG.
CHAROLA TIPO MARINO		CHAROLA TIPO MARINO		CHAROLA TIPO MARINO		CHAROLA TIPO MARINO	
VHM-100R2504535	40	THM-200R25035	40	RLM-40010035	41	RLM-400200110	41
VHM-200R2504535	40	THM-300R25035	40	RLM-50010035	41	RLM-500200110	41
VHM-300R2504535	40	THM-400R25035	40	RLM-60010035	41	RLM-600200110	41
VHM-400R2504535	40	THM-500R25035	40	RLM-30020035	41	RLM-400300110	41
VHM-500R2504535	40	THM-600R25035	40	RLM-40020035	41	RLM-500300110	41
VHM-600R2504535	40	THM-100R25060	40	RLM-50020035	41	RLM-600300110	41
VHM-100R2504560	40	THM-200R25060	40	RLM-60020035	41	RLM-500400110	41
VHM-200R2504560	40	THM-300R25060	40	RLM-40030035	41	RLM-600400110	41
VHM-300R2504560	40	THM-400R25060	40	RLM-50030035	41	RLM-600500110	41
VHM-400R2504560	40	THM-500R25060	40	RLM-60030035	41	VAM-100R20035	42
VHM-500R2504560	40	THM-600R25060	40	RLM-50040035	41	VAM-200R20035	42
VHM-600R2504560	40	THM-100R25085	40	RLM-60040035	41	VAM-300R20035	42
VHM-100R2504585	40	THM-200R25085	40	RLM-60050035	41	VAM-400R20035	42
VHM-200R2504585	40	THM-300R25085	40	RLM-20010060	41	VAM-500R20035	42
VHM-300R2504585	40	THM-400R25085	40	RLM-30010060	41	VAM-550R20035	42
VHM-400R2504585	40	THM-500R25085	40	RLM-40010060	41	VAM-600R20035	42
VHM-500R2504585	40	THM-600R25085	40	RLM-50010060	41	VAM-100R20060	42
VHM-600R2504585	40	THM-100R250110	40	RLM-60010060	41	VAM-200R20060	42
VHM-100R25045110	40	THM-200R250110	40	RLM-30020060	41	VAM-300R20060	42
VHM-200R25045110	40	THM-300R250110	40	RLM-40020060	41	VAM-400R20060	42
VHM-300R25045110	40	THM-400R250110	40	RLM-50020060	41	VAM-500R20060	42
VHM-400R25045110	40	THM-500R250110	40	RLM-60020060	41	VAM-550R20060	42
VHM-500R25045110	40	THM-600R250110	40	RLM-40030060	41	VAM-600R20060	42
VHM-600R25045110	40	XHM-100R25035	41	RLM-50030060	41	VAM-100R20085	42
VHM-100R2509035	40	XHM-200R25035	41	RLM-60030060	41	VAM-200R20085	42
VHM-200R2509035	40	XHM-300R25035	41	RLM-50040060	41	VAM-300R20085	42
VHM-300R2509035	40	XHM-400R25035	41	RLM-60040060	41	VAM-400R20085	42
VHM-400R2509035	40	XHM-500R25035	41	RLM-60050060	41	VAM-500R20085	42
VHM-500R2509035	40	XHM-600R25035	41	RLM-20010085	41	VAM-550R20085	42
VHM-600R2509035	40	XHM-100R25060	41	RLM-30010085	41	VAM-600R20085	42
VHM-100R2509060	40	XHM-200R25060	41	RLM-40010085	41	VAM-100R200110	42
VHM-200R2509060	40	XHM-300R25060	41	RLM-50010085	41	VAM-200R200110	42
VHM-300R2509060	40	XHM-400R25060	41	RLM-60010085	41	VAM-300R200110	42
VHM-400R2509060	40	XHM-500R25060	41	RLM-30020085	41	VAM-400R200110	42
VHM-500R2509060	40	XHM-600R25060	41	RLM-40020085	41	VAM-500R200110	42
VHM-600R2509060	40	XHM-100R25085	41	RLM-50020085	41	VAM-550R200110	42
VHM-100R2509085	40	XHM-200R25085	41	RLM-60020085	41	VAM-600R200110	42
VHM-200R2509085	40	XHM-300R25085	41	RLM-40030085	41	VAM-100R35035	42
VHM-300R2509085	40	XHM-400R25085	41	RLM-50030085	41	VAM-200R35035	42
VHM-400R2509085	40	XHM-500R25085	41	RLM-60030085	41	VAM-300R35035	42
VHM-500R2509085	40	XHM-600R25085	41	RLM-50040085	41	VAM-400R35035	42
VHM-600R2509085	40	XHM-100R250110	41	RLM-60040085	41	VAM-500R35035	42
VHM-100R25090110	40	XHM-200R250110	41	RLM-60050085	41	VAM-550R35035	42
VHM-200R25090110	40	XHM-300R250110	41	RLM-200100110	41	VAM-600R35035	42
VHM-300R25090110	40	XHM-400R250110	41	RLM-300100110	41	VAM-100R35060	42
VHM-400R25090110	40	XHM-500R250110	41	RLM-400100110	41	VAM-200R35060	42
VHM-500R25090110	40	XHM-600R250110	41	RLM-500100110	41	VAM-300R35060	42
VHM-600R25090110	40	RLM-20010035	41	RLM-600100110	41	VAM-400R35060	42
THM-100R25035	40	RLM-30010035	41	RLM-300200110	41	VAM-500R35060	42

INDICE POR No. DE CATALOGO

No. DE CAT.	PAG.	No. DE CAT.	PAG.	No. DE CAT.	PAG.	No. DE CAT.	PAG.
CHAROLA TIPO MARINO		CHAROLA TIPO MARINO		CHAROLA TIPO MALLA		CHAROLA TIPO MALLA	
VAM-550R35060	42	VAM-550R62535	42	PTR-40060	43	ADRN	47
VAM-600R35060	42	VAM-600R62535	42	PTR-50060	43	SCCL	47
VAM-100R35085	42	VAM-100R62560	42	PTR-60060	43	ACTMCL	47
VAM-200R35085	42	VAM-200R62560	42	PTR-10085	43	STCL	47
VAM-300R35085	42	VAM-300R62560	42	PTR-20085	43	AS	48
VAM-400R35085	42	VAM-400R62560	42	PTR-30085	43	SCCL-50	48
VAM-500R35085	42	VAM-500R62560	42	PTR-40085	43	SCCL-100	48
VAM-550R35085	42	VAM-550R62560	42	PTR-50085	43	SCCL-150	48
VAM-600R35085	42	VAM-600R62560	42	PTR-60085	43	SCCL-200	48
VAM-100R350110	42	VAM-100R62585	42	PTR-100110	43	SCCL-300	48
VAM-200R350110	42	VAM-200R62585	42	PTR-200110	43	SCCL-450	48
VAM-300R350110	42	VAM-300R62585	42	PTR-300110	43	SCCL-600	48
VAM-400R350110	42	VAM-400R62585	42	PTR-400110	43	MPP-60	48
VAM-500R350110	42	VAM-500R62585	42	PTR-500110	43	MPP-100	48
VAM-550R350110	42	VAM-550R62585	42	PTR-600110	43	MPP-150	48
VAM-600R350110	42	VAM-600R62585	42			MPP-200	48
VAM-100R50035	42	VAM-100R625110	42	CHAROLA TIPO MALLA		MPP-300	48
VAM-200R50035	42	VAM-200R625110	42	CL-5030	45	MPP-400	48
VAM-300R50035	42	VAM-300R625110	42	CL-10030	45	MPP-500	48
VAM-400R50035	42	VAM-400R625110	42	CL-15030	45	MPP-600	48
VAM-500R50035	42	VAM-500R625110	42	CL-20030	45	CPPV-60	48
VAM-550R50035	42	VAM-550R625110	42	CL-30030	45	CPPV-100	48
VAM-600R50035	42	VAM-600R625110	42	CL-5055	45	CPPV-150	48
VAM-100R50060	42	EACM-35	42	CL-10055	45	CPPV-200	48
VAM-200R50060	42	EACM-60	42	CL-15055	45	CPPV-300	48
VAM-300R50060	42	EACM-85	42	CL-20055	45	CPPV-400	48
VAM-400R50060	42	EACM-110	42	CL-30055	45	CPPV-500	48
VAM-500R50060	42	TVCCHM	43	CL-40055	45	CPPV-600	48
VAM-550R50060	42	ARM-35	43	CL-45055	45	UCSN-50	49
VAM-600R50060	42	ARM-60	43	CL-50055	45	UCSN-100	49
VAM-100R50085	42	ARM-85	43	CL-60055	45	UCSN-150	49
VAM-200R50085	42	ARM-110	43	CL-50105	45	UCSN-200	49
VAM-300R50085	42	AHM-35	43	CL-100105	45	UCSN-300	49
VAM-400R50085	42	AHM-60	43	CL-150105	45	UCSN-400	49
VAM-500R50085	42	AHM-85	43	CL-200105	45	UCSN-500	49
VAM-550R50085	42	AHM-110	43	CL-300105	45	UCSN-600	49
VAM-600R50085	42	EAM-35	43	CL-400105	45	UCSN-700	49
VAM-100R500110	42	EAM-60	43	CL-450105	45	UCSN-1000	49
VAM-200R500110	42	EAM-85	43	CL-500105	45	UCSN-2000	49
VAM-300R500110	42	EAM-110	43	CL-600105	45	UCSN-3000	49
VAM-400R500110	42	PTR-10035	43	CUCL-01	46	MSNC-50	49
VAM-500R500110	42	PTR-20035	43	CUCL-02	46	MSNC-100	49
VAM-550R500110	42	PTR-30035	43	SLCL	46	MSNC-150	49
VAM-600R500110	42	PTR-40035	43	MSUCL	46	MSNC-200	49
VAM-100R62535	42	PTR-50035	43	SUCL	46	MSNC-300	49
VAM-200R62535	42	PTR-60035	43	AT-90	46	MSNC-400	49
VAM-300R62535	42	PTR-10060	43	AD-75	47	MSNC-450	49
VAM-400R62535	42	PTR-20060	43	AD-275	47	SPCL	49
VAM-500R62535	42	PTR-30060	43	AD-250/90	47	CLIP-UNI	49

INDICE POR No. DE CATALOGO

No. DE CAT.	PAG.	No. DE CAT.	PAG.	No. DE CAT.	PAG.	No. DE CAT.	PAG.
CHAROLA TIPO MALLA		CANALETAS		DUCTO CUADRADO		DUCTO CON TAPA A PRESION	
TCCL-60	50	TCHCV-3152	60	DC-645	65	DVHTP-3007590	68
TCCL-100	50	TCHCV-3305	60	DC-845	65	DVHTP-757545	68
TCCL-150	50	TCHCV-4152	60	DC-1245	65	DVHTP-1507545	68
TCCL-200	50	TCHCV-4305	60	DT-2	65	DVHTP-3007545	68
TCCL-300	50	TCHCV-6152	60	DT-4	65	DTHTP-7575	68
TCCL-400	50	TCHCV-6305	60	DT-6	65	DTHTP-15075	68
TCCL-500	50	CSTCV-14	60	DT-8	65	DTHTP-30075	68
TCCL-600	50	MPCV-03	61	DT-12	65	DXHTP-7575GI	69
BCL-10R50	50	MPCV-04	61	DX-2	65	DXHTP-15075GI	69
BSCL-35	50	MPCV-06	61	DX-4	65	DXHTP-30075GI	69
BSCL-60	50	SDCV-03	61	DX-6	65	DRLTP-30015075	69
BSCL-100	50	SDCV-04	61	DX-8	65	DRLTP-3007575	69
		SDCV-06	61	DX-12	65	DRLTP-1507575	69
CANALETAS		SCCV-03	61	DRR-84	65	DVETP-757590	69
CHSV-3152	57	SCCV-04	61	DRR-62	65	DVITP-1507590	69
CHSV-3305	57	SCCV-06	61	DRR-64	65	DVITP-3007590	69
CHSV-4152	57			DRR-42	65	DVETP-757590	69
CHSV-4305	57	DUCTO CUADRADO		DA-2	66	DVETP-1507590	69
CHSV-6152	57	DR-21	64	DA-4	66	DVETP-3007590	69
CHSV-6305	57	DR-22	64	DA-6	66	DTVTP-7575	70
CHCV-3152	57	DR-25	64	DA-8	66	DTVTP-15075	70
CHCV-3305	57	DR-210	64	DA-12	66	DTVTP-30075	70
CHCV-4152	57	DR-41	64	DTC-2	66	TTDTP-7575	70
CHCV-4305	57	DR-42	64	DTC-4	66	TTDTP-15075	70
CHCV-6152	57	DR-45	64	DTC-6	66	TTDTP-30075	70
CHCV-6305	57	DR-410	64	DTC-8	66	ADTP-7575	70
AUCV-03	57	DR-61	64	DTC-12	66	ADTP-15075	70
AUCV-04	57	DR-62	64	DM-2	66	ADTP-30075	70
AUCV-06	57	DR-65	64	DM-4	66	ARDTP-75	70
ATCV-03	58	DR-610	64	DM-6	66	DTP-CLIPT	70
ATCV-04	58	DR-81	64	DM-8	66		
ATCV-06	58	DR-82	64	DM-12	66	DUCTO CON VENA Y CAÑUELA	
AXCV-03	58	DR-85	64	DH-2	66	DVCR-21	72
AXCV-04	58	DR-810	64	DH-4	66	DVCR-22	72
AXCV-06	58	DR-121	64	DH-6	66	DVCR-25	72
ARCV-43	58	DR-122	64	DH-8	66	DVCR-210	72
ARCV-63	58	DR-125	64	DH-12	66	DVCR-41	72
AVACV-03	59	DR-1210	64			DVCR-42	72
AVACV-04	59	DCG-2	64	DUCTO CON TAPA A PRESION		DVCR-45	72
AVACV-06	59	DCG-4	64	DTP-7575-.50	68	DVCR-410	72
AHACV-03	59	DCG-6	64	DTP-15075-.50	68	DVCR-61	72
AHACV-04	59	DCG-8	64	DTP-30075-.50	68	DVCR-62	72
AHACV-06	59	DCG-12	64	DTP-7575-1.5	68	DVCR-65	72
ACCV-03	59	DC-290	64	DTP-15075-1.5	68	DVCR-610	72
ACCV-04	59	DC-490	64	DTP-30075-1.5	68	DVCR-81	72
ACCV-06	59	DC-690	64	DTP-7575-2	68	DVCR-82	72
PTRCHCV-03	60	DC-890	64	DTP-15075-2	68	DVCR-85	72
PTRCHCV-04	60	DC-1290	64	DTP-30075-2	68	DVCR-810	72
PTRCHCV-06	60	DC-245	65	DVHTP-757590	68	DVCR-121	72
		DC-445	65	DVHTP-1507590	68	DVCR-122	72

INDICE POR No. DE CATALOGO

No. DE CAT.	PAG.	No. DE CAT.	PAG.	No. DE CAT.	PAG.	No. DE CAT.	PAG.
DUCTO CON VENA Y CAÑUELA		DUCTO CON VENA Y CAÑUELA		UNICANAL		UNICANAL	
DVCR-125	72	DVCTV-6	74	LU-1047	86	LU-2106	94
DVCR-1210	72	DVCTV-8	74	LU-1320	86	LU-2108	94
DVCG-2	72	DVCTV-12	74	LU-1376	87	LU-2109	94
DVCG-4	72			LU-1376A	87	LU-2110	94
DVCG-6	72	UNICANAL		LU-1377	87	LU-1006	95
DVCG-8	72	LU-1000	81	LU-1737	87	LU-1007	95
DVCG-12	72	LU-2000	81	LU-4047	87	LU-1008	95
DVCC-290	72	LU-3300	81	LU-1045	87	LU-1010	95
DVCC-490	72	LU-4000	81	LU-1453	88	LU-2072	96
DVCC-690	72	LU-1001	81	LU-1736	88	LU-2072A	96
DVCC-890	72	LU-2001	81	LU-4045	88	LU-2072B	96
DVCC-1290	72	LU-3301	81	LU-1026	88	LU-2072BA	96
DVCC-245	73	LU-4001	81	LU-1068	88	LU-2072C	96
DVCC-445	73	LU-5500	82	LU-1326	89	LU-2072CA	96
DVCC-645	73	LU-5501	82	LU-1458	89	LU-1075	97
DVCC-845	73	LU-6000	82	LU-1346	89	LU-1593	97
DVCC-1245	73	LU-6001	82	LU-1325	89	LU-1076	97
DVCTH-2	73	LU-3184P	82	LU-1728	89	LU-1077	97
DVCTH-4	73	PRLU-1000	83	LU-2235	89	LU-1077A	97
DVCTH-6	73	PRLU-2000	83	LU-1037	90	LU-2511	97
DVCTH-8	73	PRLU-3300	83	LU-1821	90	LU-2511A	97
DVCTH-12	73	PRLU-4000	83	LU-1033	90	LU-2513	97
DVCXH-2	73	PRLU-5500	83	LU-1034	90	LU-2513A	97
DVCXH-4	73	PRLU-6000	83	LU-1035	90	LU-2512	97
DVCXH-6	73	PSLU-1000	83	LU-1357	90	LU-2512A	97
DVCXH-8	73	PSLU-2000	83	LU-1359	91	LU-2514	97
DVCXH-12	73	PSLU-3300	83	LU-1579	91	LU-2514A	97
DVCVE-290	73	PSLU-4000	83	LU-1956	91	LU-2515	97
DVCVE-490	73	PSLU-5500	83	LU-1957	91	LU-2515A	97
DVCVE-690	73	PSLU-6000	83	LU-1727	91	LU-2516	97
DVCVE-890	73	LU-1062	84	LU-2341R	92	LU-2516A	97
DVCVE-1290	73	LU-1063	84	LU-2341L	92	LU-2517	97
DVCVE-245	74	LU-1064	84	LU-2472R	92	LU-2517A	97
DVCVE-445	74	LU-1065	84	LU-2472L	92	LU-2518	97
DVCVE-645	74	LU-1066	84	LU-2223	92	LU-2518A	97
DVCVE-845	74	LU-1067	84	LU-2224	92	LU-2539	97
DVCVE-1245	74	LU-1941	84	LU-2345	93	LU-2540	97
DVCVI-290	74	LU-2325	84	LU-2346	93	LU-2541	97
DVCVI-490	74	LU-2324	84	LU-2227	93	LU-2542	97
DVCVI-690	74	LU-1031	85	LU-2228	93	LU-2543	97
DVCVI-890	74	LU-1028	85	LU-2348	93	LU-2544	97
DVCVI-1290	74	LU-1036	85	LU-2348A	93	LU-2545	97
DVCVI-245	74	LU-1356	85	LU-2096	94	LU-2546	97
DVCVI-445	74	LU-1358	85	LU-2097	94	LU-2539A	97
DVCVI-645	74	LU-1953	85	LU-2098	94	LU-2540A	97
DVCVI-845	74	LU-1950	85	LU-1546	94	LU-2541A	97
DVCVI-1245	74	LU-1043A	86	LU-2099	94	LU-2542A	97
DVCTV-2	74	LU-1044	86	LU-2101	94	LU-2543A	97
DVCTV-4	74	LU-1046A	86	LU-2102	94	LU-2544A	97

INDICE POR No. DE CATALOGO

No. DE CAT.	PAG.	No. DE CAT.	PAG.	No. DE CAT.	PAG.	No. DE CAT.	PAG.
UNICANAL		ABRAZADERA PARA TUBERIA		ABRAZADERA PARA TUBERIA		ABRAZADERA PARA TUBERIA	
LU-2545A	97	OT-6	102	AP269-3	104	ACD-8	105
LU-2546A	97	AU-120-1/2	103	AP269-3 1/2	104	ACD-10	105
LU-12715	98	AU-120-3/4	103	AP269-4	104	ACD-12	105
LU-12725	98	AU-120-1	103	AP269-5	104	ACD-14	105
LU-17965	98	AU-120-1 1/4	103	AP269-6	104	ACD-16	105
LU- 785	98	AU-120-1 1/2	103	AP269-8	104	ACD-18	105
LU-2868	99	AU-120-2	103	ACO-260-1/2	104	ACD-20	105
LU-2867	99	AU-120-2 1/2	103	ACO-260-3/4	104	ACD-24	105
LU-2676 3/8	99	AU-120-3	103	ACO-260-1	104	AC386-3/4	105
LU-2676 1/2	99	AU-120-3 1/2	103	ACO-260-1 1/4	104	AC386-1	105
ABRAZADERA PARA TUBERIA		AU-120-4	103	ACO-260-1 1/2	104	AC386-1 1/4	105
LU-1109	101	AU-120-5	103	ACO-260-2	104	AC386-1 1/2	105
LU-1111	101	AU-120-6	103	ACO-260-2 1/2	104	AC386-2	105
LU-1112	101	AU-120-8	103	ACO-260-3	104	AC386-2 1/2	105
LU-1113	101	AU-120-10	103	ACO-260-3 1/2	104	AC386-3	105
LU-1114	101	AU-137-1 1/4	103	ACO-260-4	104	AC386-3 1/2	105
LU-1115	101	AU-137-1 1/2	103	ACO-260-6	104	AC386-4	105
LU-1117	101	AU-137-2	103	ACO-260-8	104	AC386-5	105
LU-1118	101	AU-137-2 1/2	103	ACO-260-10	104	AC386-6	105
LU-1119	101	AU-137-3	103	ACO-260-12	104	AC386-8	105
LU-1120	101	AU-137-3 1/2	103	ACO-260-14	104	APE-12	105
LU-1121	101	AU-137-4	103	ACO-260-16	104	APE-34	105
LU-1123	101	AU-137-5	103	ACO-260-18	104	APE-1	105
LU-1124	101	AU-137-6	103	ACO-260-20	104	APE-114	105
ACTM-01	102	AU-137-6	103	ACO-260-24	104	APE-112	105
ACTM-02	102	AU-137-8	103	ACO-260-30	104	APE-2	105
ACTM-04	102	AU-137-10	103	ACO-260-36	104	APE-212	105
ACCTM-12	102	AU-137-12	103	ACO65-3/8	104	APE-3	105
ACCTM-34	102	AU-137-14	103	ACO65-1/2	104	APE-312	105
ACCTM-1	102	AU-137-16	103	ACO65-3/4	104	APE-4	105
ACCTM-114	102	AU-137-18	103	ACO65-1	104	ALE-12	105
ACCTM-112	102	AU-137-20	103	ACO65-1 1/4	104	ALE-34	105
ACCTM-2	102	AU M3012	103	ACO65-1 1/2	104	ALE-1	105
ACCTM-212	102	AU M3034	103	ACO65-2	104	ALE-114	105
ACCTM-3	102	AU M301	103	ACO65-2 1/2	104	ALE-112	105
ACCTM-312	102	AU M30114	103	ACO65-3	104	ALE-2	105
ACCTM-4	102	AU M30112	103	ACO65-3 1/2	104		
OT-12	102	AU M302	103	ACO65-4	104		
OT-34	102	AU M30212	103	ACD-3/4	105		
OT-1	102	AU M303	103	ACD-1	105		
OT-114	102	AU M30312	103	ACD-1 1/4	105		
OT-112	102	AU M304	103	ACD-1 1/2	105		
OT-2	102	AP269-1/2	104	ACD-2	105		
OT-212	102	AP269-3/4	104	ACD-2 1/2	105		
OT-3	102	AP269-1	104	ACD-3	105		
OT-312	102	AP269-1 1/4	104	ACD-3 1/2	105		
OT-4	102	AP269-1 1/2	104	ACD-4	105		
OT-5	102	AP269-2	104	ACD-5	105		
		AP269-2 1/2	104	ACD-6	105		

INDICE POR No. DE CATALOGO

No. DE CAT.	PAG.	No. DE CAT.	PAG.	No. DE CAT.	PAG.	No. DE CAT.	PAG.
CHAROLA TIPO ESCALERA		ACCESORIAS TIPO ESCALERA		ACCESORIAS TIPO ESCALERA		ACCESORIAS TIPO ESCALERA	
CHC-0606	A5	VHC-16R2490	A6	VEC-12R1290	A7	VEC-09R3690	A7
CHC-0906	A5	VHC-18R2490	A6	VEC-16R1290	A7	VEC-12R3690	A7
CHC-1206	A5	VHC-20R2490	A6	VEC-18R1290	A7	VEC-16R3690	A7
CHC-1606	A5	VHC-24R2490	A6	VEC-20R1290	A7	VEC-18R3690	A7
CHC-1806	A5	VHC-30R2490	A6	VEC-24R1290	A7	VEC-20R3690	A7
CHC-2006	A5	VHC-36R2490	A6	VEC-30R1290	A7	VEC-24R3690	A7
CHC-2406	A5			VEC-36R1290	A7	VEC-30R3690	A7
CHC-3006	A5	VHC-06R3690	A6			VEC-36R3690	A7
CHC-3606	A5	VHC-09R3690	A6	VEC-06R2490	A7		
CHC-0609	A5	VHC-12R3690	A6	VEC-09R2490	A7	VIC-06R1290	A8
CHC-0909	A5	VHC-16R3690	A6	VEC-12R2490	A7	VIC-09R1290	A8
CHC-1209	A5	VHC-18R3690	A6	VEC-16R2490	A7	VIC-12R1290	A8
CHC-1609	A5	VHC-20R3690	A6	VEC-18R2490	A7	VIC-16R1290	A8
CHC-1809	A5	VHC-24R3690	A6	VEC-20R2490	A7	VIC-18R1290	A8
CHC-2009	A5	VHC-30R3690	A6	VEC-24R2490	A7	VIC-20R1290	A8
CHC-2409	A5	VHC-36R3690	A6	VEC-30R2490	A7	VIC-24R1290	A8
CHC-3009	A5			VEC-36R2490	A7	VIC-30R1290	A8
CHC-3609	A5	VHC-06R1245	A6			VIC-36R1290	A8
CHC-0612	A5	VHC-09R1245	A6	VEC-06R3690	A7		
CHC-0912	A5	VHC-12R1245	A6	VEC-09R3690	A7	VIC-06R2490	A8
CHC-1212	A5	VHC-16R1245	A6	VEC-12R3690	A7	VIC-09R2490	A8
CHC-1612	A5	VHC-18R1245	A6	VEC-16R3690	A7	VIC-12R2490	A8
CHC-1812	A5	VHC-20R1245	A6	VEC-18R3690	A7	VIC-16R2490	A8
CHC-2012	A5	VHC-24R1245	A6	VEC-20R3690	A7	VIC-18R2490	A8
CHC-2412	A5	VHC-30R1245	A6	VEC-24R3690	A7	VIC-20R2490	A8
CHC-3012	A5	VHC-36R1245	A6	VEC-30R3690	A7	VIC-24R2490	A8
CHC-3612	A5			VEC-36R3690	A7	VIC-30R2490	A8
CHC-0618	A5	VHC-06R2445	A6			VIC-36R2490	A8
CHC-0918	A5	VHC-09R2445	A6	VEC-06R1245	A7		
CHC-1218	A5	VHC-12R2445	A6	VEC-09R1245	A7	VIC-06R3690	A8
CHC-1618	A5	VHC-16R2445	A6	VEC-12R1245	A7	VIC-09R3690	A8
CHC-1818	A5	VHC-18R2445	A6	VEC-16R1245	A7	VIC-12R3690	A8
CHC-2018	A5	VHC-20R2445	A6	VEC-18R1245	A7	VIC-16R3690	A8
CHC-2418	A5	VHC-24R2445	A6	VEC-20R1245	A7	VIC-18R3690	A8
		VHC-30R2445	A6	VEC-24R1245	A7	VIC-20R3690	A8
		VHC-36R2445	A6	VEC-30R1245	A7	VIC-24R3690	A8
				VEC-36R1245	A7	VIC-30R3690	A8
						VIC-36R3690	A8
ACCESORIAS TIPO ESCALERA							
VHC-06R1290	A6	VHC-06R3645	A6	VEC-06R2445	A7	VIC-06R1245	A8
VHC-09R1290	A6	VHC-09R3645	A6	VEC-09R2445	A7	VIC-09R1245	A8
VHC-12R1290	A6	VHC-12R3645	A6	VEC-12R2445	A7	VIC-12R1245	A8
VHC-16R1290	A6	VHC-16R3645	A6	VEC-16R2445	A7	VIC-16R1245	A8
VHC-20R1290	A6	VHC-18R3645	A6	VEC-18R2445	A7	VIC-18R1245	A8
VHC-24R1290	A6	VHC-20R3645	A6	VEC-20R2445	A7	VIC-20R1245	A8
VHC-30R1290	A6	VHC-24R3645	A6	VEC-24R2445	A7	VIC-24R1245	A8
VHC-36R1290	A6	VHC-30R3645	A6	VEC-30R2445	A7	VIC-30R1245	A8
		VHC-36R3645	A6	VEC-36R2445	A7	VIC-36R1245	A8
VHC-06R2490	A6			VEC-06R1290	A7		
VHC-09R2490	A6	VEC-06R1290	A7	VEC-09R1290	A7		
VHC-12R2490	A6	VEC-09R1290	A7				
				VEC-06R3690	A7		

INDICE POR No. DE CATALOGO

No. DE CAT.	PAG.	No. DE CAT.	PAG.	No. DE CAT.	PAG.	No. DE CAT.	PAG.
ACCESORIAS TIPO ESCALERA		ACCESORIAS TIPO ESCALERA		ACCESORIAS TIPO ESCALERA		ACCESORIAS TIPO ESCALERA	
VIC-06R2445	A8	XHC-06R12	A9	RLDC-3012	A10	RLIC-3020	A10
VIC-09R2445	A8	XHC-09R12	A9	RLDC-3612	A10	RLC-3620	A10
VIC-12R2445	A8	XHC-12R12	A9	RLDC-1816	A10	RLIC-3024	A10
VIC-16R2445	A8	XHC-16R12	A9	RLDC-2016	A10	RLC-3624	A10
VIC-18R2445	A8	XHC-18R12	A9	RLDC-2416	A10	RLIC-3630	A10
VIC-20R2445	A8	XHC-20R12	A9	RLDC-3016	A10		
VIC-24R2445	A8	XHC-24R12	A9	RLDC-3616	A10	RLC-0906	A10
VIC-30R2445	A8	XHC-30R12	A9	RLDC-2018	A10	RLC-1206	A10
VIC-36R2445	A8	XHC-36R12	A9	RLDC-2418	A10	RLC-1606	A10
				RLDC-3018	A10	RLC-1806	A10
VIC-06R3645	A8	XHC-06R24	A9	RLDC-3618	A10	RLC-2004	A10
VIC-09R3645	A8	XHC-09R24	A9	RLDC-2420	A10	RLC-2406	A10
VIC-12R3645	A8	XHC-12R24	A9	RLDC-3020	A10	RLC-3006	A10
VIC-16R3645	A8	XHC-16R24	A9	RLDC-3620	A10	RLC-3606	A10
VIC-18R3645	A8	XHC-18R24	A9	RLDC-3024	A10	RLC-1209	A10
VIC-20R3645	A8	XHC-20R24	A9	RLDC-3624	A10	RLC-1609	A10
VIC-24R3645	A8	XHC-24R24	A9	RLDC-3630	A10	RLC-1809	A10
VIC-30R3645	A8	XHC-30R24	A9			RLC-2009	A10
VIC-36R3645	A8	XHC-36R24	A9	RLIC-0906	A10	RLC-2409	A10
				RLIC-1206	A10	RLC-3009	A10
THC-06R12	A9	XHC-06R36	A9	RLIC-1606	A10	RLC-3609	A10
THC-09R12	A9	XHC-09R36	A9	RLIC-1806	A10	RLC-1612	A10
THC-12R12	A9	XHC-12R36	A9	RLIC-2004	A10	RLC-1812	A10
THC-16R12	A9	XHC-16R36	A9	RLIC-2406	A10	RLC-2012	A10
THC-18R12	A9	XHC-18R36	A9	RLIC-3006	A10	RLC-2412	A10
THC-20R12	A9	XHC-20R36	A9	RLIC-3606	A10	RLC-3012	A10
THC-24R12	A9	XHC-24R36	A9	RLIC-1209	A10	RLC-3612	A10
THC-30R12	A9	XHC-30R36	A9	RLIC-1609	A10	RLC-1816	A10
THC-36R12	A9	XHC-36R36	A9	RLIC-1809	A10	RLC-2016	A10
				RLIC-2009	A10	RLC-2416	A10
THC-06R24	A9	RLDC-0906	A10	RLIC-2409	A10	RLC-3016	A10
THC-09R24	A9	RLDC-1206	A10	RLIC-3009	A10	RLC-3616	A10
THC-12R24	A9	RLDC-1606	A10	RLIC-3609	A10	RLC-2018	A10
THC-16R24	A9	RLDC-1806	A10	RLIC-1612	A10	RLC-2418	A10
THC-18R24	A9	RLDC-2004	A10	RLIC-1812	A10	RLC-3018	A10
THC-20R24	A9	RLDC-2406	A10	RLIC-2012	A10	RLC-3618	A10
THC-24R24	A9	RLDC-3006	A10	RLIC-2412	A10	RLC-2420	A10
THC-30R24	A9	RLDC-3606	A10	RLIC-3012	A10	RLC-3020	A10
THC-36R24	A9	RLDC-1209	A10	RLIC-3612	A10	RLC-3620	A10
		RLDC-1609	A10	RLIC-1816	A10	RLC-3024	A10
THC-06R36	A9	RLDC-1809	A10	RLIC-2016	A10	RLC-3624	A10
THC-09R36	A9	RLDC-2009	A10	RLIC-2416	A10	RLC-3630	A10
THC-12R36	A9	RLDC-2409	A10	RLIC-3016	A10		
THC-16R36	A9	RLDC-3009	A10	RLIC-3616	A10	TVC-06R12	A11
THC-18R36	A9	RLDC-3609	A10	RLIC-2018	A10	TVC-09R12	A11
THC-20R36	A9	RLDC-1612	A10	RLIC-2418	A10	TVC-12R12	A11
THC-24R36	A9	RLDC-1812	A10	RLIC-3018	A10	TVC-16R12	A11
THC-30R36	A9	RLDC-2012	A10	RLIC-3618	A10	TVC-18R12	A11
THC-36R36	A9	RLDC-2412	A10	RLIC-2420	A10	TVC-20R12	A11

INDICE POR No. DE CATALOGO

No. DE CAT.	PAG.	No. DE CAT.	PAG.	No. DE CAT.	PAG.	No. DE CAT.	PAG.
CHAROLA TIPO ESCALERA		ACCESORIAS TIPO ESCALERA		ACCESORIAS TIPO ESCALERA		ACCESORIAS TIPO ESCALERA	
TVC-24R12	A11	CHCV-10305FV	A15	THCV-10R12FV	A16	LU-1068FV	A23
TVC-30R12	A11	CHSV-3610FV	A15	XHSV-03R12FV	A17	LU-1326FV	A23
TVC-36R12	A11	CHSV-4610FV	A15	XHSV-04R12FV	A17	LU-1458FV	A23
TVC-06R24	A11	CHSV-6610FV	A15	XHSV-06R12FV	A17	LU-1346FV	A23
TVC-09R24	A11	CHSV-8610FV	A15	XHSV-09R12FV	A17	LU-1325FV	A23
TVC-12R24	A11	CHSV-10610FV	A15	XHSV-10R12FV	A17	LU-1357FV	A24
TVC-16R24	A11	CHCV-3610FV	A16	XHCV-03R12FV	A17	LU-1359FV	A24
TVC-18R24	A11	CHCV-4610FV	A16	XHCV-04R12FV	A17	LU-1579FV	A24
TVC-20R24	A11	CHCV-6610FV	A16	XHCV-06R12FV	A17	LU-1727FV	A24
TVC-24R24	A11	CHCV-8610FV	A16	XHCV-09R12FV	A17	LU-1728FV	A24
TVC-30R24	A11	CHCV-10610FV	A16	XHCV-10R12FV	A17	LU-2235FV	A24
TVC-36R24	A11	VHSV-03R1290FV	A16	TRCHSV-3FV	A17	LU-111FV	A25
TVC-06R36	A11	VHSV-04R1290FV	A16	TRCHSV-4FV	A17	LU-112FV	A25
TVC-09R36	A11	VHSV-06R1290FV	A16	TRCHSV-6FV	A17	LU-113FV	A25
TVC-12R36	A11	VHSV-08R1290FV	A16	TRCHSV-8FV	A17	LU-114FV	A25
TVC-16R36	A11	VHSV-10R1290FV	A16	TRCHSV-10FV	A17	LU-115FV	A25
TVC-18R36	A11	VHCV-03R1290FV	A16	TRCHCV-3FV	A17	LU-117FV	A25
TVC-20R36	A11	VHCV-04R1290FV	A16	TRCHCV-4FV	A17	LU-118FV	A25
TVC-24R36	A11	VHCV-06R1290FV	A16	TRCHCV-6FV	A17	LU-119FV	A25
TVC-30R36	A11	VHCV-08R1290FV	A16	TRCHCV-8FV	A17	LU-120FV	A25
TVC-36R36	A11	VHCV-10R1290FV	A16	TRCHCV-10FV	A17	LU-121FV	A25
BS-FV	A11	VESV-03R1290FV	A16	ARSV-03FV	A17	LU-3008FV	A25
AR-FV	A12	VESV-04R1290FV	A16	ARSV-04FV	A17	LU-3010FV	A25
AE-FV	A12	VESV-06R1290FV	A16	ARSV-06FV	A17	LU-17965FV	A25
EA-FV	A12	VESV-08R1290FV	A16	ARSV-08FV	A17	LU-2072AFV	A25
AV22-FV	A12	VESV-10R1290FV	A16	ARSV-10FV	A17	LU-2072FV	A25
AV30-FV	A12	VECV-03R1290FV	A16	ARCV-03FV	A17	LU2676-38FV	A26
AV45-FV	A12	VECV-04R1290FV	A16	ARCV-04FV	A17	LU2676-12FV	A26
AV60-FV	A12	VECV-06R1290FV	A16	ARCV-06FV	A17	LU2676-58FV	A26
AV90-FV	A12	VECV-08R1290FV	A16	ARCV-08FV	A17	LU2676-34FV	A26
PTR-06FV	A12	VECV-10R1290FV	A16	ARCV-10FV	A17	VR-38FV	A26
PTR-09FV	A12	VISV-03R1290FV	A16	LU-1000FV	A20	VR-12FV	A26
PTR-12FV	A12	VISV-04R1290FV	A16	LU-1001FV	A20	VR-58FV	A26
PTR-16FV	A12	VISV-06R1290FV	A16	PSLU-1000FV	A 20	VR-34FV	A26
PTR-18FV	A12	VISV-08R1290FV	A16	LU-1064FV	A21	VR-100FV	A26
PTR-20FV	A12	VISV-10R1290FV	A16	LU-1065FV	A21	TCHA-38FV	A26
PTR-24FV	A12	VICV-04R1290FV	A16	LU-1066FV	A21	TCHA-12FV	A26
PTR-30FV	A12	VICV-06R1290FV	A16	LU-1067FV	A21	TCHA-58FV	A26
PTR-36FV	A12	VICV-08R1290FV	A16	LU-1941FV	A21	TCHA-34FV	A26
CLAMP-FV	A12	VICV-10R1290FV	A16	LU-2324FV	A21	TCHA-100FV	A26
CHSV-3305FV	A15	THSV-03R12FV	A16	LU-2325FV	A21	ROP-38FV	A26
CHSV-4305FV	A15	THSV-04R12FV	A16	LU-1028FV	A22	ROP-12FV	A26
CHSV-6305FV	A15	THSV-06R12FV	A16	LU-1031FV	A22	ROP-58FV	A26
CHSV-8305FV	A15	THSV-09R12FV	A16	LU-1036FV	A22	ROP-34FV	A26
CHSV-10305FV	A15	THSV-10R12FV	A16	LU-1356FV	A22	ROP-100FV	A26
CHCV-3305FV	A15	THCV-03R12FV	A16	LU-1358FV	A22	CVR-38FV	A26
CHCV-4305FV	A15	THCV-04R12FV	A16	LU-1953FV	A22	CVR-12FV	A26
CHCV-6305FV	A15	THCV-06R12FV	A16	LU-1950FV	A22	CVR-58FV	A26
CHCV-8305FV	A15	THCV-09R12FV	A16	LU-1026FV	A23	CVR-34FV	A26
						CVR-100FV	A26

SOPORTES ELECTRICOS

NOTAS

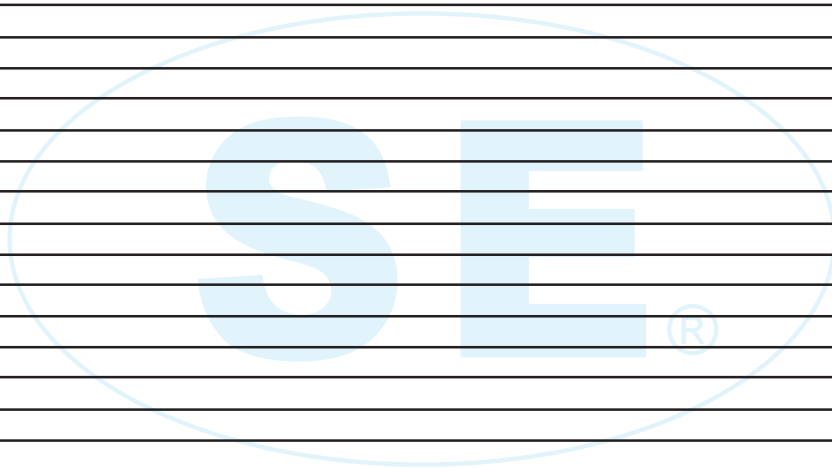
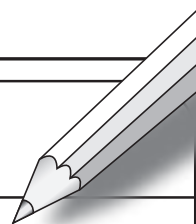

SOPORTES ELECTRICOS

NOTAS

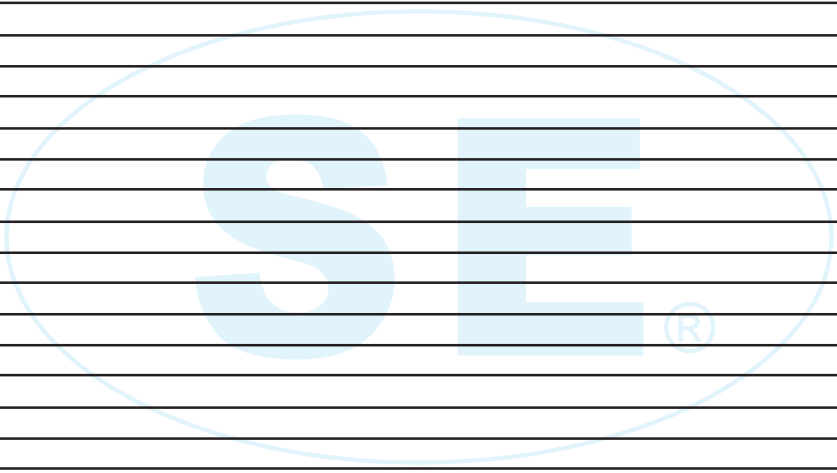
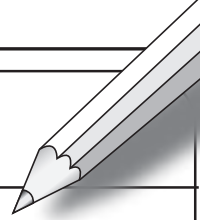

Planta Monterrey

SOPORTES ELECTRICOS

Bernardo Reyes #3743 Nte.

Col. Niño Artillero C. P. 64280

Monterrey, N. L.

Tels. 01 (81) 8351-6244 / (81) 8531-6445

(81) 8331-7293 Fax 01 (81) 83318183

Planta México

SOPORTES ELECTRICOS

Calle Tezcaltlipoca #15

San Miguel Xochimanga C. P. 52927

Cd. López Mateos, Estado de México

Tels. 01 (55) 5367-4197 / (55) 5367-8572

(55) 5876-8901 / 1926 / 9725

México, D. F. Suc. Doctores

SOPORTES ELECTRICOS

Dr. Olvera #8 C Col. Doctores

Cuauhtémoc C. P. 06720 México, D. F.

Tels. 01 (55) 3547-3854 / (55) 3547-3855

(55) 9130-9544 / (55) 9130-9566

México, D. F. Suc. Centro

SOPORTES ELECTRICOS

Calle Pescaditos Loc. 23 B y C

Col. Centro C. P. 06090 México, D. F.

Tel. 01 (55) 3622-9824 / 3622-9825

(55) 5521-5749 / (55) 5510-3530

Guadalajara, Jal.

SOPORTES ELECTRICOS

Calle Río Lagos # 1674 Col. Atlas

C. P. 44870 Guadalajara, Jal.

Tel. 01 (33) 3614-0917

(33) 3614-0918

Querétaro, Qro.

SOPORTES ELECTRICOS

Av. Bambu # 23 Col. el Carizal

C. P. 76030 Querétaro, Qro.

Tel. 01 (44) 2215-5289

(44) 2242-8082

San Luis Potosí, S. L. P.

SOPORTES ELECTRICOS

Av. Salvador Nava #516 Local 1 Col. Nuevo Paseo

C.P. 78250 San Luis Potosí, S.L.P.

Tel. 01 (444) 822-6767

(444) 822-2735

Puebla, Pue.

Av. 15 De Mayo No.3515

Col Fracc. Villa De San Alejandro

Entre La 35 Norte Y 37 Norte. C.P. 72090

TEL 01 22 26 88 78 89.

01 22 22 26 22 06

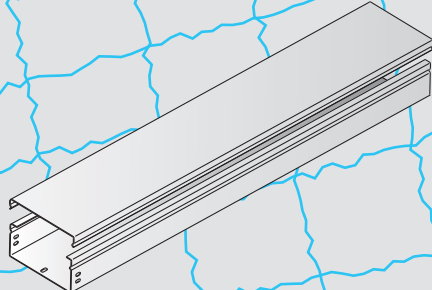
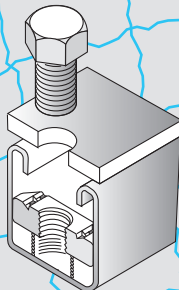
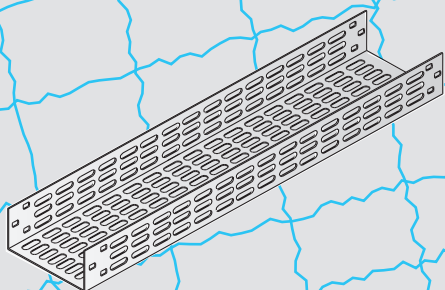

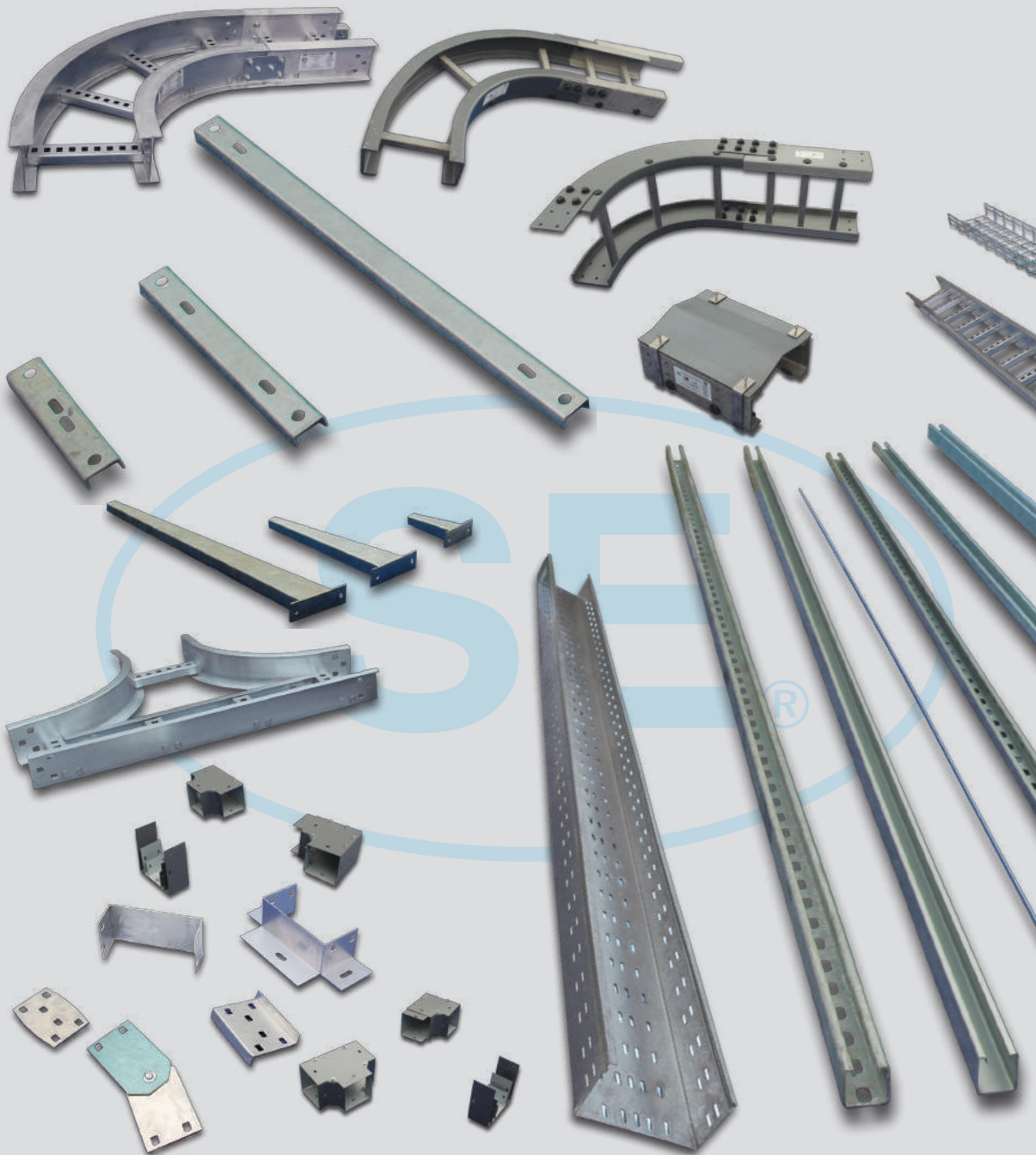

www.soporteselectricos.com.mx

E-mail: soporteselectricos@prodigy.net.mx

ventas@soporteselectricos.com.mx